

VARMAX

GAS CONDENSING BOILER

120 to 450 kW

with modulating burner
for natural gas and propane gas



Document No. 00BNO9061-L / 18.04.16

FR EN DE ES IT NL

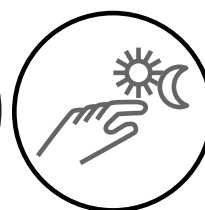
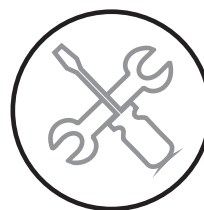

Installation, use and maintenance instructions

MANUFACTURER:



SITE DE PONT-DE-VAUX
1 route de Fleurville - BP 55
FR - 01190 PONT-DE-VAUX



CONTENTS

1. WARNINGS AND RECOMMENDATIONS	6
1.1. Transport and storage	6
1.2. Symbols used in this document.	6
1.3. Qualification of personnel for installing, adjusting, using and maintaining the equipment	6
1.4. Safety instructions.....	6
1.5. Water characteristics.....	7
2. APPROVALS	10
2.1. Compliance with European Directives	10
2.2. Regulatory installation conditions.....	10
2.3. Gas category.....	10
2.4. Gas supply pressures	11
3. TECHNICAL SPECIFICATIONS	12
3.1. Dimensions	12
3.2. Doorways	14
3.3. Combustion at 15°C and 1013 mbar.....	15
3.4. Conditions of use	17
3.5. Electrical connection	17
4. INSTALLATION	18
4.1. Installation of the air filter and filter matting.....	18
4.2. Installing the boiler	19
4.3. Opening / closing of casing doors	20
4.4. Removing the control panel (MMI).....	20
4.5. Removing / refitting the casing doors.....	21
4.6. Removing / refitting side panels	22
4.7. Removing / refitting the top panel	22
4.8. Step.....	23
4.9.Changing the gas type (G20 to G31).....	24
4.10.Exhaust connection.....	26
4.11.Hydraulic connection	34
4.12.Gas connection	36
4.13.Electrical connection	36

5. COMMISSIONING.....	40
5.1. Unlocking the boiler.....	40
5.2. Pre-commissioning checks	40
5.3. Commissioning.....	41
6. POST-COMMISSIONING CHECK.....	42
6.1. Condensate removal	42
6.2. Gas supply	42
7. MAINTENANCE OPERATIONS	43
7.2. Verification of the boiler's environment.....	44
7.3. Replacing the air filter matting.....	44
7.1. Boiler draining	44
7.4. Verification of ignition and ionisation electrodes	45
7.5. Siphon cleaning.....	46
7.6. Checking the combustion circuit's gas-tightness.....	46
7.7. Checking combustion quality	47
7.8. Setting the gas valve.....	48
7.9. Gas filter cleaning	50
7.10.Cleaning exchangers and changing seals.....	51
7.11.Cleaning the burner and changing the seals.....	53
8. END-OF-LIFE CYCLE OF THE APPARATUS.....	56
9. HYDRAULIC DIAGRAMS AND SETTINGS	57
9.1. Selection flow diagram	57
9.2. Symbols used in the diagrams	59
9.3. List of diagrams.....	59
10. LIST OF SPARE PARTS.....	116
11. TABLE OF CUSTOMER SETTINGS	127
12. ANNEX A.....	144

1. WARNINGS AND RECOMMENDATIONS

PLEASE READ THIS MANUAL CAREFULLY BEFORE INSTALLING, CARRYING OUT MAINTENANCE AND USING THE BOILER. IT CONTAINS IMPORTANT SAFETY INFORMATION.



INFORMATION:

VARMAX boilers are available with 2/3 tapplings or 4 tapplings. It is not possible to transform a version with 2/3 tapplings into a version with 4 tapplings and vice versa.

1.1. Transport and storage

The boiler:

- must be stored vertically in an environment where the temperature is between -20°C and +55°C, and where relative humidity is between 5% and 95%;
- must not be stacked,
- must be protected from humidity.

1.2. Symbols used in this document.



INFORMATION:

This symbol draws attention to comments.



WARNING:

Not following these instructions may lead to damage when installing or to other objects.



DANGER:

Not following these instructions may cause injuries and serious material damage.



DANGER:

Not following these instructions may cause electrocution.

1.3. Qualification of personnel for installing, adjusting, using and maintaining the equipment

Boiler installation, adjustment and maintenance operations must be conducted by a qualified and approved professional in accordance with prevailing local and national regulations. These operations may require work to be carried out with the power turned on and the casing doors (on the front of the boiler) open.

Basic utilisation operations must be carried out with the casing doors closed.

1.4. Safety instructions

- Always switch the boiler off and shut off the general gas supply before carrying out any work on the boiler.
- After performing work on the boiler (maintenance or breakdown), check that there are no gas leaks from the installation.

**DANGER:****If you smell gas:**

- Do not use a naked flame, do not smoke, do not turn on electrical contacts or switches.
- Cut off the gas supply.
- Air the premises.
- Look for the leak and repair it.

**DANGER:****If you see smoke:**

- Switch off the boiler.
- Air the premises.
- Look for the leak and repair it.

**DANGER:**

This boiler's earth bonding is ensured with connecting cables (green/yellow) and specific attachment screws. During any dismantling work, make sure you reconnect the cables concerned; it is **IMPERATIVE** to reuse the original attachment screws.

1.5. Water characteristics

The following rules apply as soon as the boiler is commissioned and remain valid until the product's end-of-life.

**DANGER:**

It is forbidden to use water containing glycol.

1.5.1. Preparation of the water circuit before commissioning the boiler

For all installation work (new or renovation), the water network pipes must be meticulously cleaned. The purpose of cleaning prior to commissioning is to remove germs and residues which are the cause of deposits.

In new installations in particular, residue from grease, oxidised metal and even copper micro deposits must be removed.

In renovated installations, cleaning should focus on removing sludge and the products of corrosion formed when the unit was last in operation.

There are two types of methods for cleaning and removing sludge: a high intensity approach that takes a few hours and a slower, more gradual approach that takes several weeks. This first type of cleaning must be done before connecting the new boiler, and with the second type, a filter should be installed on the back of the boiler to capture loosened deposits.

Cleaning prior to commissioning helps to improve the equipment's performance, reduce energy consumption and fight against scaling and corrosion. This operation must be done by a professional (water treatment).

1.5.2. Protecting the unit against scaling

Water naturally contains dissolved calcium ions and carbonates that cause scaling (calcium carbonate) to form. To prevent excessive deposits, take precautions with regard to the water used to fill the unit **TH < 10°f**

Water must be added during the life of the boiler. The new water adds scaling to the water system. The amount of fill water and the amount of make-up water added throughout the unit's lifecycle must not be more than three times the water capacity of the heating system. Also, the hardness of the make-up water must be controlled. Make-up water: **TH < 5°f**

Adding a large amount of untreated water always contributes a significant amount of scaling. To monitor this and to detect problems, a system water meter must be installed.

Failure to comply with these guidelines (such that the fill water plus the make-up water is more than three times the water capacity of the heating system) requires a full cleaning (to remove sludge and scaling) to be performed.

Additional precautions are required for operation:

- When the unit has a water softener, the equipment must be inspected on a regular basis in order to ensure that it is not outputting chloride-rich water into the system. The concentration of chlorides must always remain below 50 mg/litre.
- To prevent the build-up of calcium deposits (such as on exchange surfaces), the unit should be brought into service slowly, starting by operating at a low power with high primary water flow.
- When the tap water lacks the desired qualities (e.g. high level of hardness), water treatment is required. The fill water must be treated, and whenever new water is added, the make-up water must also be treated.
- Installations with multiple boilers require all of the boilers to be started simultaneously at minimal power. Doing this prevents the calcium in the water from depositing on the exchange surfaces of the first boiler.
- When working on the unit, avoid draining it completely; only the required parts of the system are to be drained.

The rules listed above are designed to minimise scaling on the exchange surfaces and thus to increase the life of the boilers.

To optimise the equipment's operation, remove lime scale deposits. This must be done by a specialised company. Also, before putting the unit into service, verify that the heating system is not damaged (e.g. leaks). If it has excessive scaling, the unit's settings for operation and for water treatment must be adjusted.

1.5.3. Protecting steel and stainless steel boilers against corrosion

Corrosion can affect the iron components used in boilers and heating systems, which is directly related to the presence of oxygen in the water heater's water. Dissolved oxygen that enters the unit when it is being filled for the first time reacts with the equipment materials and quickly disappears. Without refreshing the oxygen through significant contributions of water, the unit might not experience any damage whatsoever.

However, it is important to follow the sizing rules and installation guidelines in order to prevent oxygen from continuously flowing into the heating water.

These rules include:

- Opt for an expansion vessel with a membrane rather than an open expansion vessel that allows direct passage.
- Make sure pressure in the equipment is more than 1 bar when cold.
- Remove non-gas-tight components (permeable) and use gas-tight equipment instead.

If the guidelines above are followed, the unit's system water has the proper characteristics to last a long time: $8.2 < \text{pH} < 9.5$ and concentration in dissolved oxygen < 0.1 mg/litre.

If there is a chance that oxygen could enter the unit, you must take additional precautions. Adding an oxygen scavenger (e.g. sodium sulphite) is highly recommended. We recommend you contact specialised companies for water treatment issues, which will be able to suggest:

- the appropriate treatment based on the characteristics of the installation,
- a monitoring and performance warranty contract.

For units in which the water comes into contact with heterogeneous materials, such as copper or aluminium, appropriate treatment is recommended in order to ensure that the unit will last. In most cases, this consists of adding corrosion inhibitors (in the form of chemical solutions) to the unit. It is recommended to contact water treatment specialists.

1.5.4. Unit monitoring

If the above recommendations are followed (new installation or renovation), it should be sufficient to:

- check the amount of make-up water (fill water volume + make-up water volume < 3 times the unit volume).
- check the pH level (stable or slightly increasing).
- check the TH (stable or slightly decreasing).

We recommend these checks are carried out 2 to 3 times a year. Note that monitoring the quantity of make-up water is critical to the long life of the unit. If any of these three parameters deviates from the above recommendations, refer to a water treatment specialist to correct the problem.

1.5.5. Installation of the plate exchanger

If the recommendations above cannot be met, you can set up a plate exchanger to separate the primary system from the secondary system, which protects the boiler from undesirable effects.

1.5.6. Installation of a filtration system

A filtration system (filter, sediment well, etc.) on the back of the boiler is recommended in order to remove suspended particles from the unit.

2. APPROVALS

2.1. Compliance with European Directives

- Low voltage (2006/95/CE)

This appliance is not intended for use by persons (including children) whose physical, sensory or mental abilities are reduced, or persons without experience or knowledge, unless they have been able to benefit, through someone responsible for their safety, from supervision or prior instruction concerning the use of the appliance.

Children must be supervised to ensure they do not play with the appliance.

- Electromagnetic compatibility (2004/108/CEE)

- Gas appliances (2009/142/CE)

- Efficiency (92/42/CEE) until 26/09/2015

- Eco-design (2009/125/EC): from 26/09/2015

In application of the directive and according to the requirements of the EU regulation No. 813/2013 of 02 August 2013, the technical parameters of condensation boilers with a power of less than or equal to 400 kW are available in appendix A.

2.2. Regulatory installation conditions

The appliance must be installed by an approved professional in accordance with regulations and current professional practices.

2.3. Gas category

This boiler has been adjusted in the factory to work with **group H (type G20) natural gas with a supply pressure of 20 mbar.**



INFORMATION: Any work on a sealed element leads to loss of warranty.

		Category	
		DK, EE, FI, HU, LV, NO, SE, TR	CZ, GR, GB, IE, LT, RO, SI, SK
VARMAX 120 to 225	B23 - B23 P	I _{2H}	II _{2H3P}
	C13 - C33 - C53		I _{2H}
VARMAX 275 to 320	B23 - B23 P	I _{2H}	II _{2H3P}
	C53		I _{2H}
VARMAX 390 to 450	B23 - B23 P	I _{2H}	I _{2H}
	C53		

2.4. Gas supply pressures



INFORMATION: The pressures given below must be read at the gas valve inlet.

	Natural gas H G20 20 mbar	G31 Propane gas (for relevant models and countries only)
Nominal pressure (mbar)	20	37
Minimum pressure (mbar)	17	25
Maximum pressure (mbar)	25	45

		MODELS							
		120	140	180	225	275	320	390	450
A	(mm)	734	734	734	734	812	812	912	912
B	(mm)	1530	1530	1780	1780	1877	1877	2023	2023
C	(mm)	1189	1189	1218	1218	1341	1341	1392	1392
D	(mm)	148	148	169	169	169	169	168	168
E	(mm)	103	103	150	150	109	109	92	92
F	(mm)	510	510	630	630	680	680	750	750
G	(mm)	138,5	138,5	138,5	138,5	138,5	138,5	138,5	138,5
H	(mm)	115	115	192	192	241	241	274,5	274,5
I	(mm)	350,5	350,5	350,5	350,5	399,5	399,5	449,5	449,5
J	(mm)	150,5	150,5	150,5	150,5	200	200	209,5	209,5
K	(mm)	166,5	166,5	150,5	150,5	179	179	192	192
L	(mm)	1256	1256	1564	1564	1672	1672	1874	1874
M	(mm)	165	165	165	165	165	165	165	165
N	(mm)	182	182	197,5	197,5	196,5	196,5	206,5	206,5
O	(mm)	926	926	1171	1171	1265	1265	1402	1402
P	(mm)	1062	1062	1315	1315	1413	1413	1577,5	1577,5
Q	(mm)	1298	1298	1606	1606	1661	1661	1933	1933
R	(mm)	212	212	212	212	244	244	244	244
S	(mm)	163	163	163	163	163	163	183	183
Ø T(*): Smoke outlet	(mm)	150	150	150	150	180	180	200	200
Ø U: Purge connecting sleeve		1 "	1 "	1 "	1 "	1 "	1 "	1 "	1 "
Ø V(*): Air inlet	(mm)	150	150	150	150	180	180	180	180
Ø W: Gas connecting sleeve	G20 G31	1 " 1/4 1 " 1/4	1 " 1/4 1 " 1/4	1 " 1/2 1 " 1/2	1 " 1/2 1 " 1/2	2 " 2 "	2 " 2 "	2 " --	2 " --
Ø X: Out / In connecting sleeve		Mail thread 2 "	Mail thread 2 "	Flange PN16 DN 65	Flange PN16 DN 65	Flange PN16 DN 80	Flange PN16 DN 80	Flange PN16 DN 80	Flange PN16 DN 80
Y	(mm)	250,5	250,5	247	247	276	276	289,5	289,5
Z	(mm)	237	237	224,5	224,5	270,5	270,5	283,5	283,5
Ø AA: Valve connecting sleeve		1 "	1 "	1 "	1 "	1 " 1/4	1 " 1/4	1 " 1/4	1 " 1/4
AB	(mm)	≈ 130	≈ 130	≈ 130	≈ 130	≈ 130	≈ 130	≈ 130	≈ 130
AC	(mm)	≈ 110	≈ 110	≈ 110	≈ 110	≈ 110	≈ 110	≈ 120	≈ 120

(*) The diameter indicated is the inside diameter (only for Ø T and Ø V).

3.2. Doorways

VARMAX 120 to 225 boilers fit through doors 700 mm wide with the casing on (boiler with doors and side jackets).

VARMAX 275 to 320 boilers fit through doors 735 mm wide without the casing on (boiler without doors, without side jackets and without side insulating panels).

However, it is possible to pass through the 700 mm doors if the following parts are removed, in addition to the parts mentioned above:

- the two inspection doors with their 16 fastening clamps,
- the two lower hinge lugs of the front housing doors (with the step),
- the two upper hinge lugs of the front housing doors (with the step),
- all the cable clamps at the inlet of the high- and low- current wiring gutter.

VARMAX 390 to 450 boilers fit through doors 800 mm wide without the casing on, which means that the following parts must be removed:

- the two front housing doors,
- the side insulating jackets,
- the side insulating panels
- the two lower hinge lugs of the front housing doors (with the step),
- the two upper hinge lugs of the front housing doors (with the step),
- all the cable clamps at the inlet of the high- and low- current wiring gutter.

3.3. Combustion at 15°C and 1013 mbar

3.3.1. G20 Natural Gas

		MODELS							
		120	140	180	225	275	320	390	450
Nominal power Pn (80/60°C)	kW	117	136	175	219	268	312	381	439
Nominal power when condensing P (50/30°C)	kW	127	148	191	238	290	338	415	478
Nominal heat input Qn	kW	120	140	180	225	275	320	390	450
Minimum heat input Qmin	kW	28	28	43	43	66	66	87	87
Gas flow rate at Pn	m³/h	12,7	14,81	19,05	23,81	29,1	33,86	41,3	47,6
CO ₂ value ranges	%	Qmin : 8,3 % < CO ₂ < 8,7 % Qmax : 8,8 % < CO ₂ < 9,2 %							
Flue-gas mass flow rate at Qn / Qmin (80/60°C)	g/s	52,8 / 13	61,3 / 13,1	80,4 / 20,8	99,5 / 21,1	113,9 / 26,9	133,2 / 29,1	169 / 39,2	200,7 / 35,6
Flue-gas mass flow rate at Qn / Qmin (50/30°C)	g/s	49,1 / 12,3	57,6 / 12,2	75,9 / 19,5	93,0 / 19,5	108,7 / 17,1	126,3 / 27,1	159,6 / 36,7	191 / 33,4
Flue-gas temperature at Qn / Qmin (80/60°C)	°C	60,8 / 56,9	62,1 / 57,3	61,0 / 56,6	62,3 / 57,7	61,7 / 58,3	63,4 / 57,2	62,5 / 57,4	64,8 / 57,1
Flue-gas temperature at Qn / Qmin (50/30°C)	°C	35,7 / 28,8	37,7 / 30,2	33,7 / 30,0	36,9 / 30,2	36,3 / 29,8	36,2 / 28,3	36,7 / 30	41,7 / 30,2
Appliance pressure at nominal Qcal (B23)	Pa	88	108	103	147	132	162	152	203
Inside diameter of flue-gas output	mm	150	150	150	150	180	180	200	200
Maximum allowable nozzle pressure (B23P) at Qn / Qmin (80/60°C)	Pa	200 / 5	200 / 5	115 / 5	165 / 5	122 / 5	176 / 5	180 / 5	193 / 5
Maximum allowable nozzle pressure (B23P) at Qn / Qmin (50/30°C)	Pa	166 / 5	164 / 5	92 / 5	128 / 5	97 / 5	145 / 5	155 / 5	173 / 5
Combustion air flow rate at Qn	m³/h	153,8	179,4	230,7	288,3	352,4	410,1	499,8	576,7
NOx class		6							
Flue-gas removal and air inlet type classifications		B23, B23P C13, C33, C53				B23, B23P C53			

3.3.2. G31 Propane Gas (for relevant models and destination countries)

		MODELS					
		120	140	180	225	275	320
Nominal power P _n (80/60°C)	kW	117	136	175	219	268	312
Nominal power when condensing P (50/30°C)	kW	127	148	191	238	290	338
Nominal heat input Q _n	kW	120	140	180	225	275	320
Minimum heat input Q _{min}	kW	39	39	63	63	90	90
Gas flow rate at P _n	m ³ /h	4,91	5,73	7,36	9,21	11,25	13,09
CO ₂ value ranges	%	Q _{min} : 9,8 % < CO ₂ < 10,2 % Q _{max} : 10,4 % < CO ₂ < 10,8 %					
Flue-gas mass flow rate at Q _n / Q _{min} (80/60°C)	g/s	53 / 18,3	61,8 / 18,3	80 / 29	100 / 29	122 / 42	142 / 42
Flue-gas mass flow rate at Q _n / Q _{min} (50/30°C)	g/s	50,2 / 17,3	58,7 / 17,3	80 / 28	96 / 28	117 / 39	136 / 40
Flue-gas temperature at Q _n / Q _{min} (80/60°C)	°C	60,3 / 56,7	62,6 / 56,7	60,3 / 57,1	62,2 / 57,6	63 / 58	65,4 / 58,4
Flue-gas temperature at Q _n / Q _{min} (50/30°C)	°C	34,6 / 30,6	37,1 / 28,9	37,1 / 31	37 / 29,4	40 / 29	41,4 / 31,3
Appliance pressure at nominal Q _{cal} (B23)	Pa	68	95	102	140	123	165
Inside diameter of flue-gas output	mm	150	150	150	150	180	180
Maximum allowable nozzle pressure (B23P) at Q _n / Q _{min} (80/60°C)	Pa	167 / 12	200 / 8	103 / 4	136 / 7	118 / 11	157 / 11
Maximum allowable nozzle pressure (B23P) at Q _n / Q _{min} (50/30°C)	Pa	140 / 16	169 / 11	66 / 7	104 / 7	104 / 16	138 / 13
Combustion air flow rate at Q _n	m ³ /h	153,8	179,4	230,7	288,3	352,4	410,1
NO _x class		6					
Flue-gas removal and air inlet type classifications		B23, B23P					

3.4. Conditions of use

		MODELS							
		120	140	180	225	275	320	390	450
Maximum start setting temperature	°C	85							
Start maximum temperature	°C	88							
Safety temperature	°C	110							
Maximum service pressure	hPa (bar)	6000 (6)							
Minimum cold pressure	hPa (bar)	1000 (1)							
Hydraulic pressure loss at ΔT_{20} version with 2 or 3 tappings version with 4 tappings Main exchanger Condenser	daPa								
		600	750	570	810	820	1185	770	970
		500	650	440	660	790	1060	660	840
		110	120	55	75	50	65	190	230
Nominal water flow rate (P/20)	m ³ /h	5,0	5,8	7,5	9,4	11,5	13,4	16,4	18,9
Maximal water flow rate (P/10)	m ³ /h	10,0	11,6	15,0	18,8	23,0	26,8	32,8	37,8
Water content	L	116	116	151	151	239	239	287	287
Weight without water	kg	340	340	393	393	502	502	592	592
Sound power at P_{max} (Lw) *	dB(A)	80		76		77		84	
Sound pressure at 1 m at P_{max} (Lp)	dB(A)	65		61		61		68	
Temperature of installation room (min. / max.)	°C	5 / 45							
Relative humidity of installation room		between 5% and 95%							
Protection level		IP20							
Maximum altitude of installation	m	2000							

* The sound power level is a laboratory measurement of the emitted sound power but contrary to the noise level, it doesn't correspond to the perceived measurement.

3.5. Electrical connection

		MODELS							
		120	140	180	225	275	320	390	450
Electrical supply	V	230 V AC (+10% -15%), 50Hz							
Electrical power consumption at Q_n (without accessories)	W	204	311	179	320	238	352	480	660
Electrical power consumption in standby mode	W	5							
Max length of sensor cables	m	DHW sensor: 10 External sensor: 40 in 0.5 mm ² (120 in 1.5 mm ²) Ambient thermostat: 200 in 1.5 mm ² Ambient sensor: 200 in 1.5 mm ²							
Power terminal output	V	230V AC (+10%, -15%)							
	A	5 mA - 1A							

4. INSTALLATION



DANGER:

Manipulation of the boiler using a hoist requires the use of a frame (not supplied). This is **COMPULSORY**. Refer to the label stuck onto the boiler's packaging.

4.1. Installation of the air filter and filter matting



WARNING:

If connecting CHIMNEY B23 or B23P, it is **COMPULSORY** to fit the air filter supplied with the boiler.

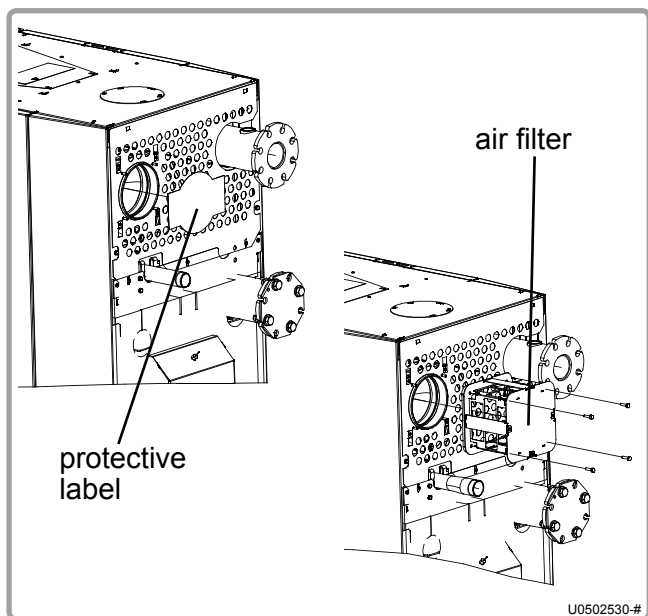

figure 2 - Air filter

- Remove the protective "air intake" label.
- Insert the air filter and attach it to the boiler using the 4 screws supplied with the filter.

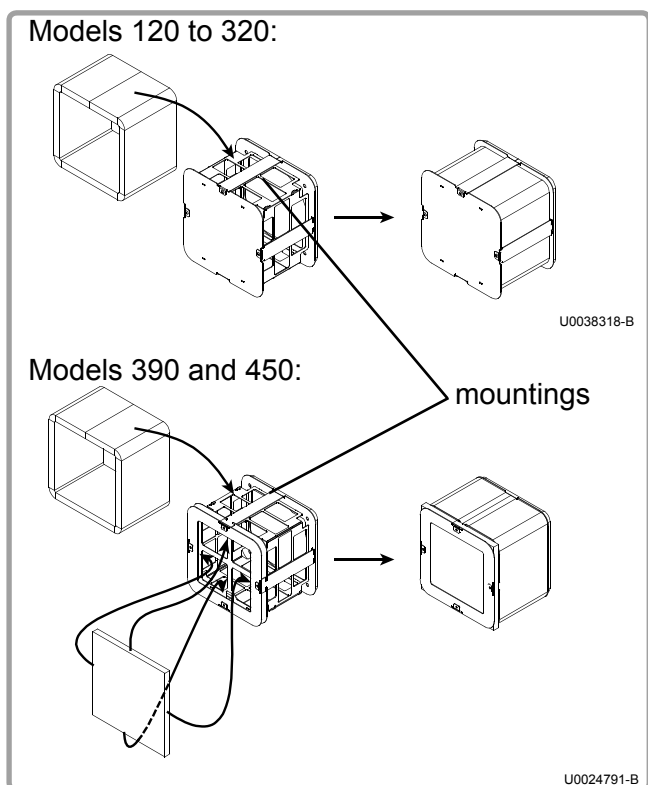

figure 3 - Filter matting

All models:

- Insert the rectangular filter matting between the filter's protective grille and the mounting (see opposite).

Ensure that the link between both ends of the matting is under one of the mountings.

Models 390 and 450:

- Insert the square filter cloth on the back gate of the filter.

4.2. Installing the boiler

VARMAX boilers must not be installed on an inflammable surface (wooden floor, plastic floor covering, etc.).

Recommended distances from walls and the floor:

Ensure there is sufficient clearance so that work may be carried out easily on the boilers.

The **minimum** values (in mm) are indicated in figure 4 and in the table below.

	A	B	C	D	H
MODELS	120	450	500		150
	140	450	500		150
	180	450	500		320
	225	450	500		320
	275	450	600	500	263
	320	450	600	500	263
	390	450	700	500	427
	450	450	700	500	427

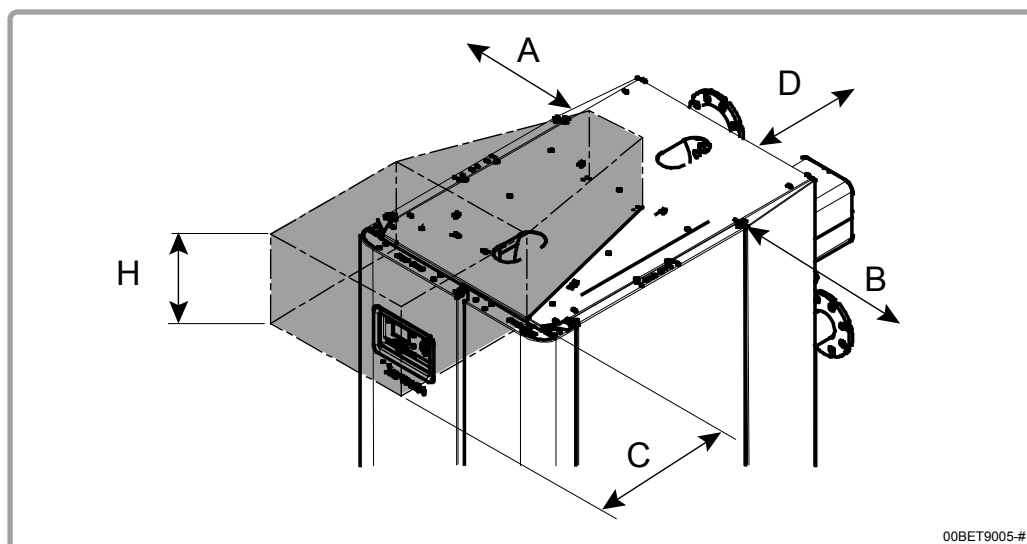

figure 4 - Peripheral clearance

The hashed zone above the boiler must remain free of obstacles to allow for inspections and cleaning of the burner.



WARNING:

A 2 cm free space must also be left above the side panels to allow for their disassembly and reassembly.

These values cannot be replaced by specific regulatory requirements.



WARNING:

The boiler must be positioned horizontally using a spirit level to promote effective ventilation of the heat exchanger (use the base as a reference surface).

To adjust the level, screw or unscrew the 4 adjustable feet as required using a 17 mm wrench.

4.3. Opening / closing of casing doors

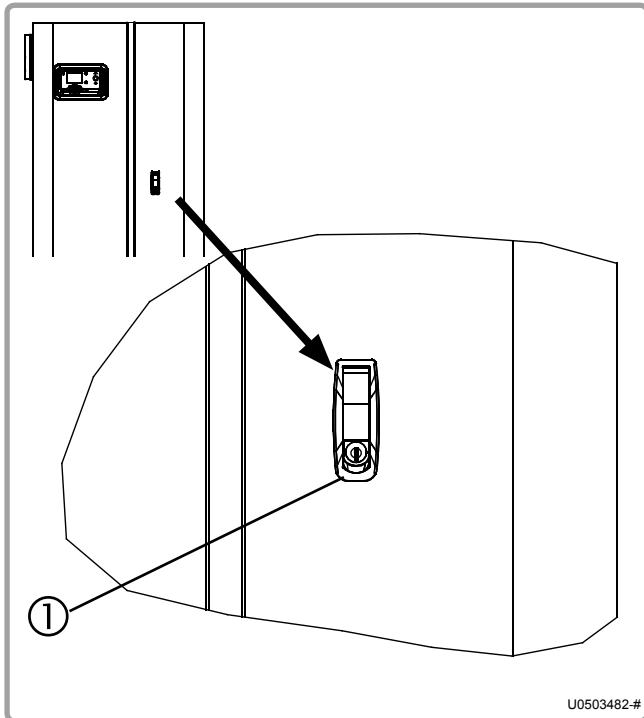

figure 5 - Opening casing doors

Opening:

Put the handle locking system in a horizontal position (mark 1) then press down on it.

The handle is released from its housing; you can now open the right-hand door, followed by the left-hand door.

Closing:

Close the left-hand door, followed by the right-hand door.

Press the door's lever.

Put the handle locking system in a vertical position (mark 1).

4.4. Removing the control panel (MMI)

The control panel (MMI: Man Machine Interface) may be removed from the casing door to:

- remove the left-hand casing door;
- view the display when setting or carrying out maintenance work on the boiler;

Open the casing doors.

Remove the locking screw ① accessible on the back of the left-hand casing door.

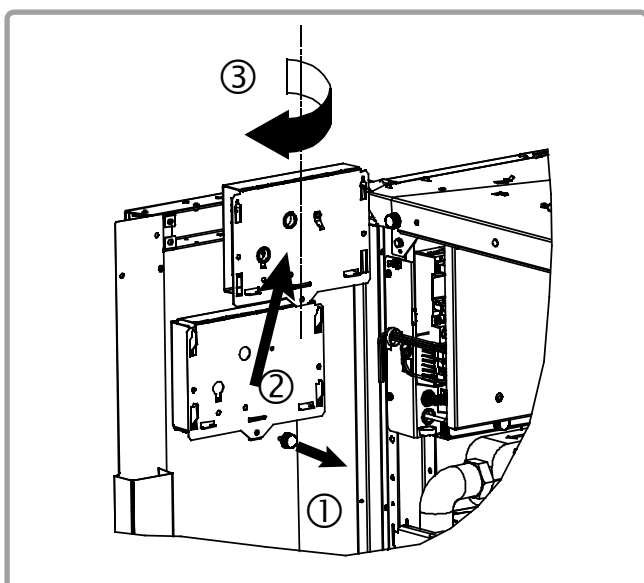

figure 6 - Unlocking the control panel

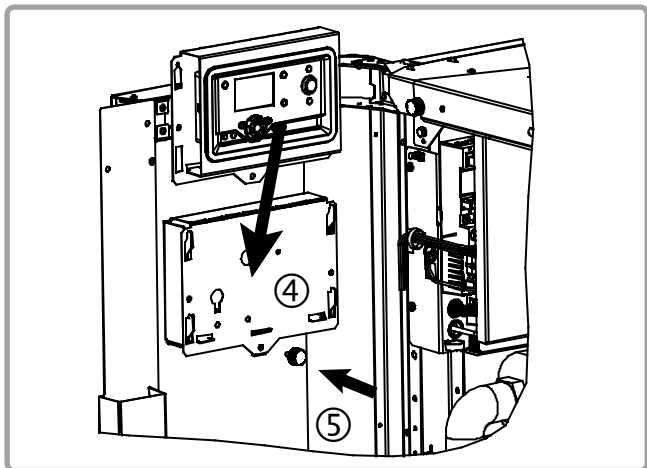

figure 7 - Positions of the control panel

You can:

- put the control panel back ②-③ in its place ④-⑤ (to view data displayed when adjusting or carrying out maintenance), or
- fit the control panel to the boiler (see opposite, so that the left-hand casing door can be removed without any risk to the control panel).

4.5. Removing / refitting the casing doors

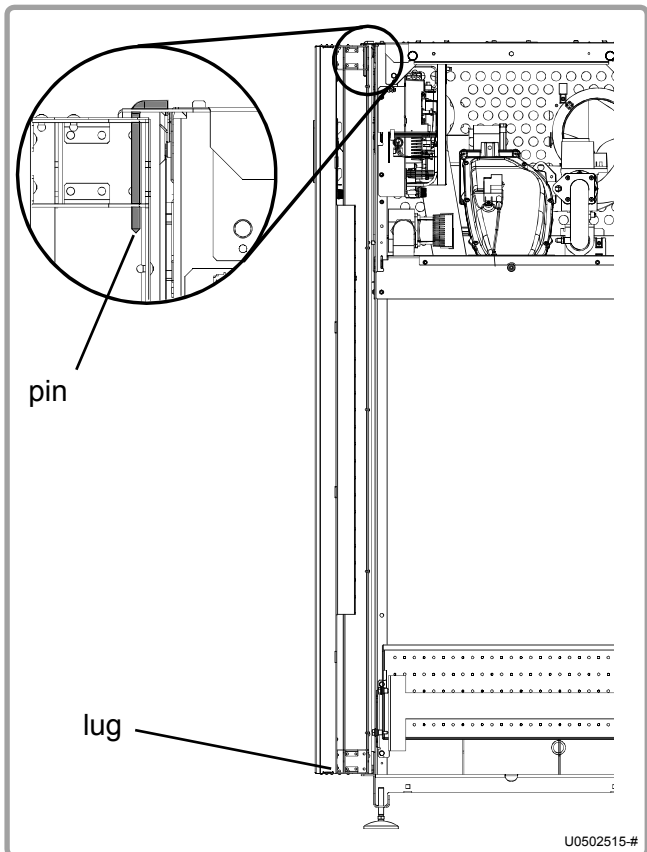

figure 8 - Removing casing doors

With the doors open, remove the pin on the top of the door to be removed.

Support the door during this operation because once the pin has been removed, the door is no longer attached to the boiler.

When refitting, firstly position the bottom of the door on the lug, and then the top, making sure to fully insert the pin into its housing.



WARNING:

Before removing the left-side casing door, do not forget to remove the control panel (see next paragraph).

4.6. Removing / refitting side panels

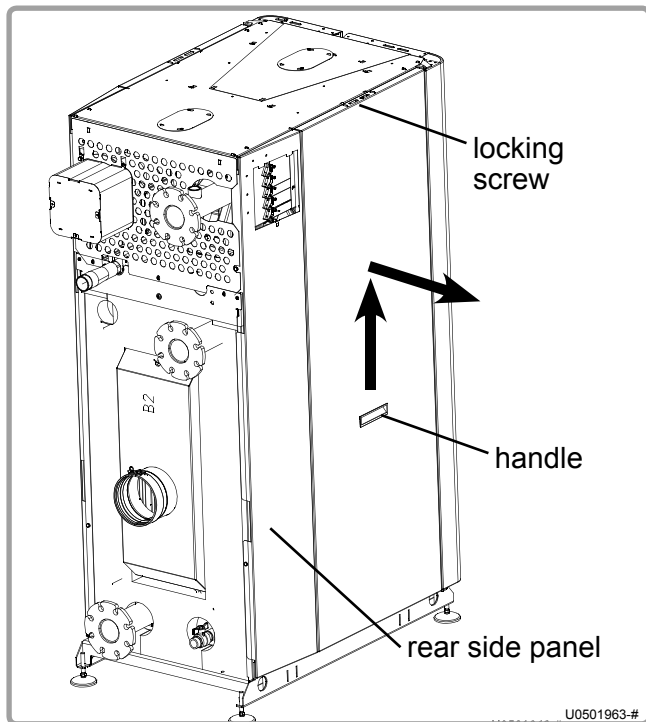

figure 9 - Removing side panels

Open the casing doors.

Remove the locking screw accessible via the inside of the boiler.

Use the handle in the centre of the panel for this.

Lift up the panel vertically and remove.

When refitting, re-fasten the locking screws from inside the boiler after fitting the panels.

Note: It may be necessary to remove the rear side panels in order to fit through doors. To do this, unscrew the fixing screws which hold the panel onto the boiler's structure and remove the panel.

4.7. Removing / refitting the top panel

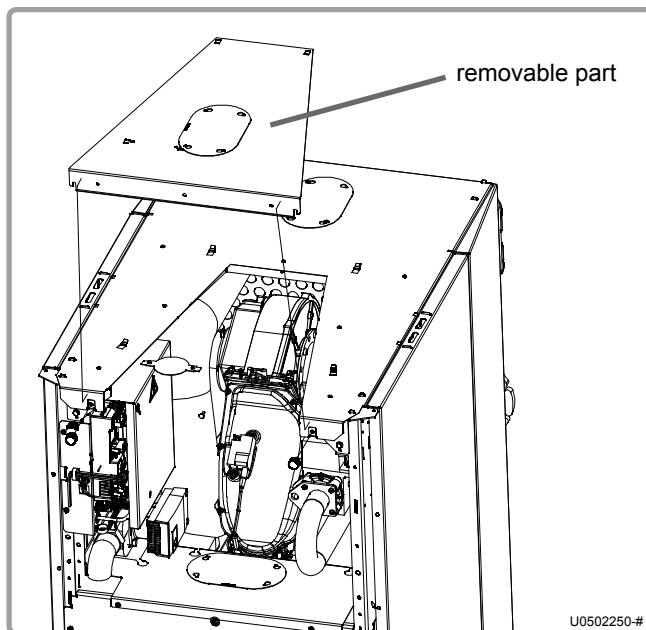

figure 10 - Removing the upper panel

Open the casing doors.

Loosen the 2 thumbscrews on the top of the boiler (1 or 2 turns will be enough. It is not necessary or recommended to unscrew them completely).

Slightly lift up the panel and remove it from the front.

To refit it, follow the procedure in reverse.

4.8. Step



WARNING:

The step is a means to access the burner. It cannot be used as a work platform.

There are steps on models 180 and above.

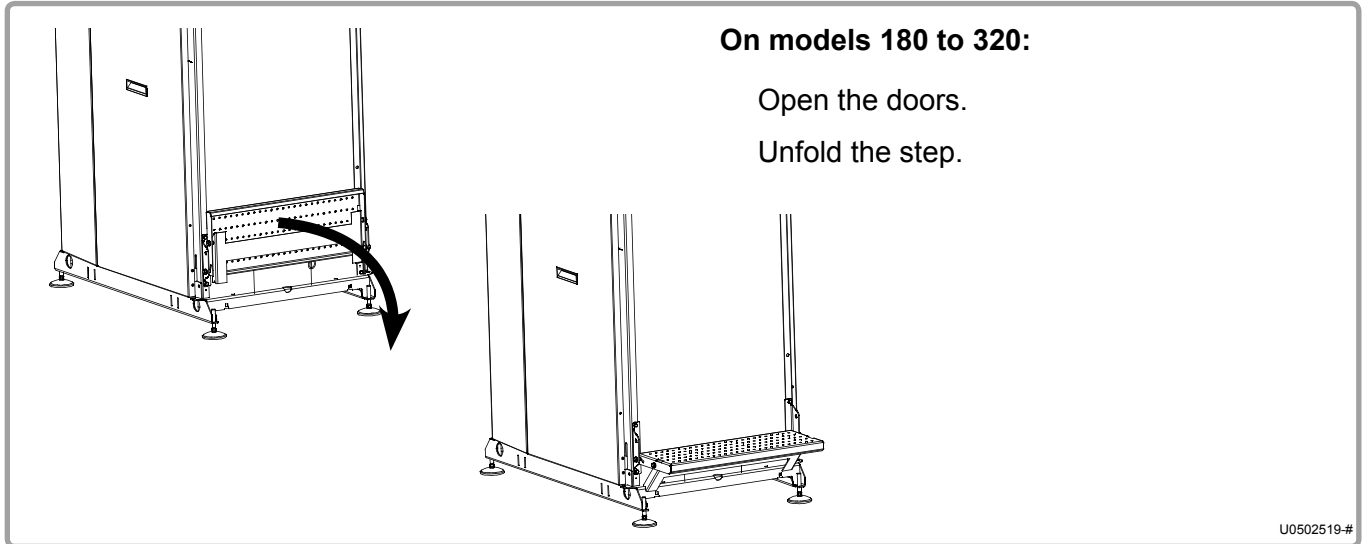

figure 12 - Installing the step on models 180-320

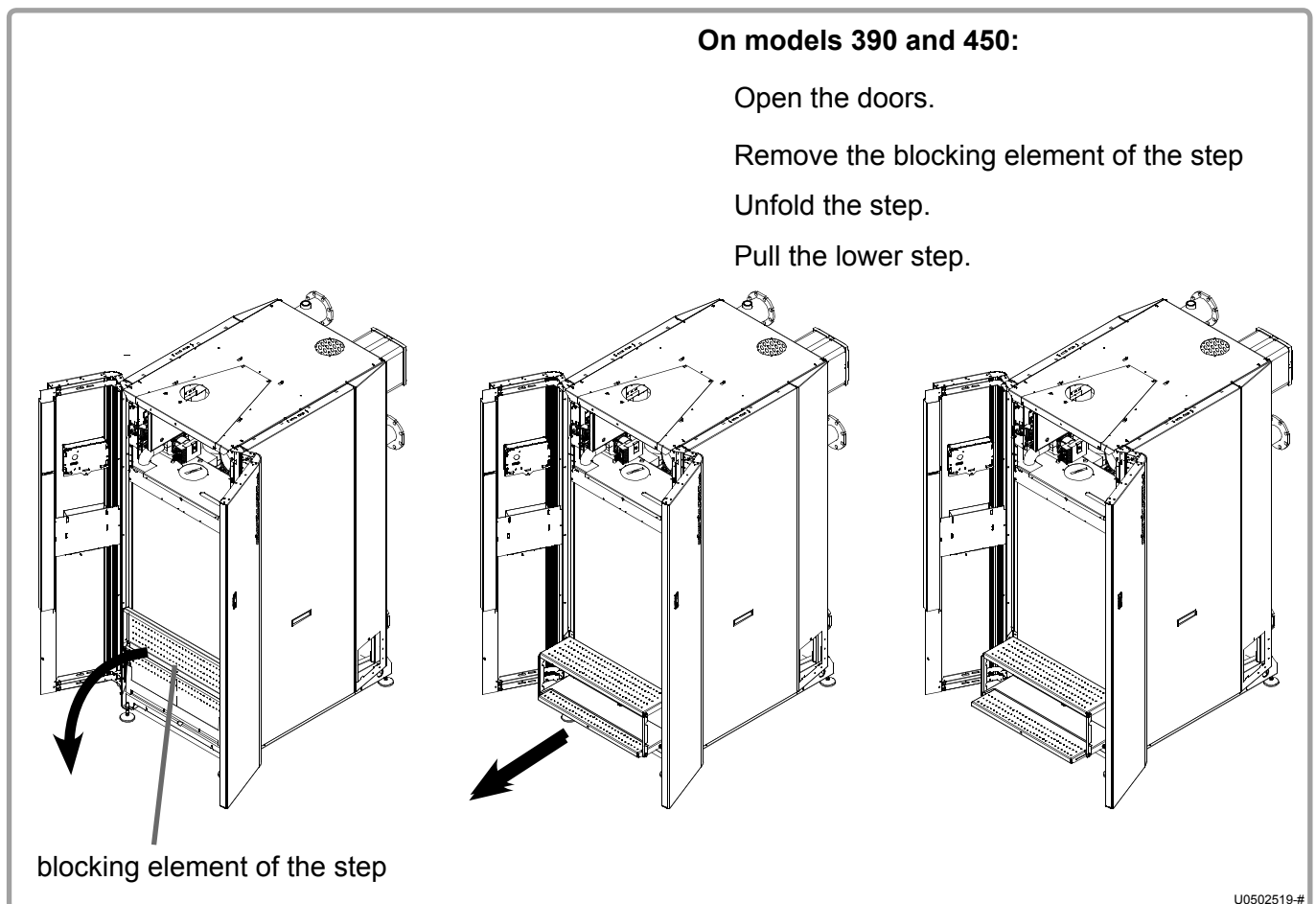

figure 13 - Installing the step on models 390 and 450

4.9. Changing the gas type (G20 to G31)



INFORMATION:

The boiler has been adjusted in the factory to work with group H (type G20) natural gas with a supply pressure of 20 mbar. Its adaptation to suit any other type of gas must take place in compliance with the regulations in effect in the country in which the appliance is installed.



WARNING:

Any operations involving changing the type of gas used must be performed by a qualified professional.



WARNING:

ONLY for relevant boilers (see paragraph 2.6, page 13) and boilers connected to B23 and B23P.

4.9.1. Changing prepurging, ignition, minimum and maximum speeds

Place the boiler in standby mode (see § 3.3.1 of the NAVISTEM B3000 boiler command table instructions).

If necessary, press the ESC button to return to the main screen.

Access the **Settings** menu.

Adjust the prepurging speed (9504), ignition speed (9512), minimum speed (9524) and maximum speed (9529) settings:

Models	Gas	9504	9512	9524	9529
120	G20			1690	6490
	G31			2040	5800
140	G20			1690	7460
	G31			2040	6800
180	G20	2390	2390	1280	4410
	G31	2575	2575	1640	4240
225	G20	2390	2390	1280	5400
	G31	2575	2575	1640	5060
275	G20			1360	4620
	G31			1700	4500
320	G20			1360	5450
	G31			1700	5300

4.9.2. On VARMAX 120, 140, 275 and 320

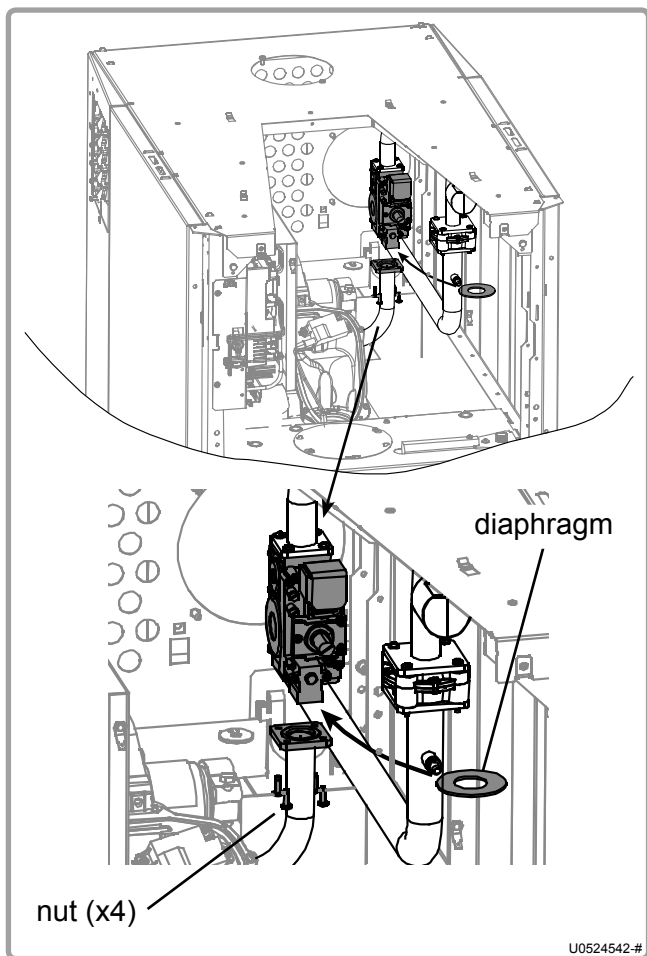

figure 14 - Diaphragm (120 and 140 models)

The type of gas is changed by installing the diaphragm (brass part) provided with the boiler (engraved B1P for 120 and 140 models or engraved B3P for 275 and 320 models).

Unscrew the 4 nuts or screws depending on the model (see opposite).

Install the diaphragm provided.

Screw the 4 nuts back in place.

Check the CO₂ settings (see § 7.7, page 52).

After changing the type of gas:

- Check the sealing of the gas line.
- Stick the label provided in place of the original label (G20).

Note:

In order to facilitate the operation, the mounting flange located at the entrance to the gas line (on the side nearest the network connection) may require unscrewing.

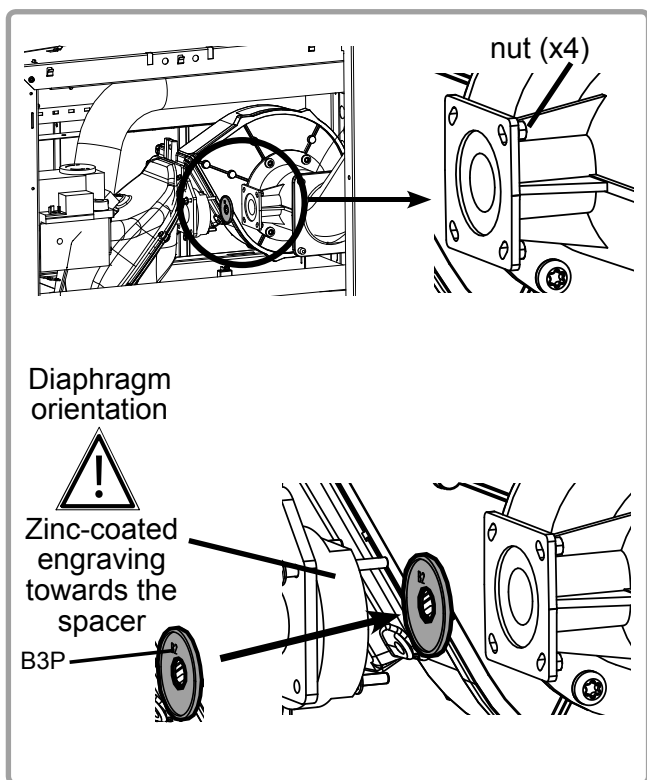

figure 15 - Diaphragm (275 and 320 models)

4.9.3. On VARMAX 180 and 225

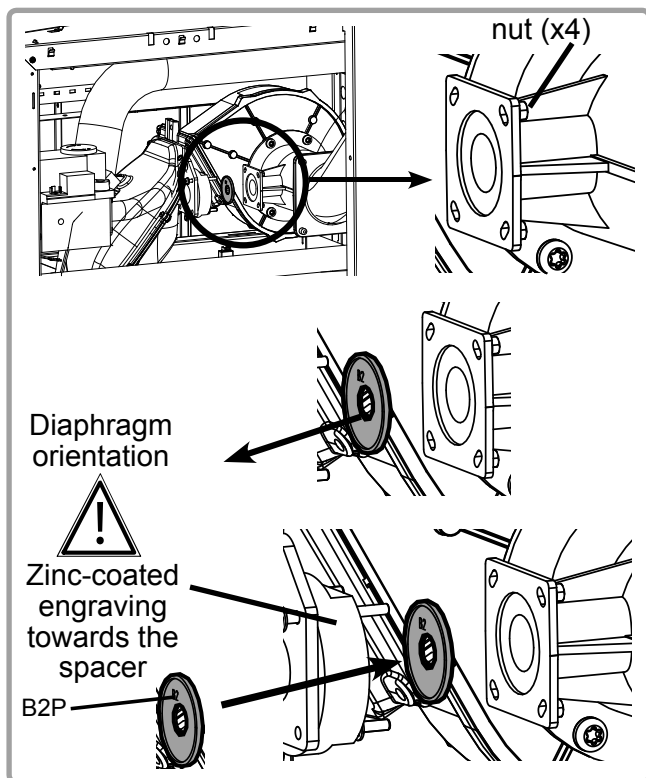

figure 16 - Diaphragm

The type of gas is changed by replacing the diaphragm located on the gas line.

Unscrew the 4 nuts (see opposite), then remove the diaphragm in place (brass part). Replace this with that provided with the boiler (engraved B2P). Screw the 4 nuts back in place.

Check the CO₂ settings (see § 7.7, page 52).

After changing the type of gas:

- Check the sealing of the gas line.
- Stick the label provided in place of the original label (G20).

Note:

In order to facilitate the operation, the mounting flange located at the entrance to the gas line (on the side nearest the network connection) may require unscrewing.

4.10. Exhaust connection

Exhaust system works and national and prefectural regulations must be complied with.

A smoke temperature sensor guarantees the protection of exhaust ducts for type B and C combustion products.

VARMAX boilers are approved to be connected to:

- a B23 chimney (all models)
- a B23P chimney (all models)
- a C13 air vent (models 120 to 225) except for propane gas (G31)
- a C33 air vent (models 120 to 225) except for propane gas (G31)
- a C53 air vent (all models) except for propane gas (G31)



INFORMATION:

The lengths of the ducts provided below are in linear metres (lm). The total length of all ducts is reduced to a straight length (elbows having a straight equivalence).

4.10.1. Connection to a B23 chimney

Type B23 connection:

Air from the unit's premises, extraction of gases through the roof via a flue with natural ventilation.



WARNING:

Check that there are top and bottom ventilations in the boiler premises, that they comply with applicable regulations and that they are not obstructed.

Chimney flues must be dimensioned considering the combustible gas pressure at the boiler outlet of 0 Pa (see table § 3.3, page 15).

The flue-gas extraction ducts must be made in a material resistant to the condensate that can form when the boiler is operating. These materials must also be capable of supporting temperatures up to 120°C. Horizontal duct runs must be avoided so as not to cause condensate retention.

Check that the fuel gas is extracted via a gas-tight duct.

VARMAX boilers are efficient boilers with very low flue-gas temperatures; as a result, to maintain favourable ventilation, the ducts must run upwards from the boiler outlet.



IMPORTANT:

If several boilers are connected to a single flue, check:

1. that the flue is not under pressure when all the boilers are in operation.
2. If one of the boilers is operating at minimum power, that the others do not discharge into it.

Sizing recommendations based on a POUJOLAT system (Condensor type):

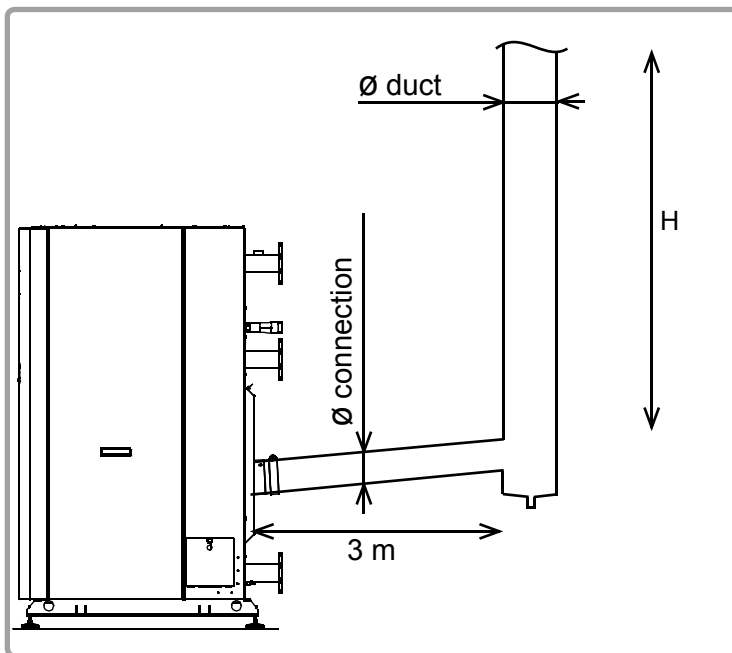

figure 17 - B23 sizing recommendations

Height of flue-gas duct H in linear metres (lm)
(operating at 50/30°C)

Ø connection	150 mm						180 mm		200 mm	
	180 mm		200 mm		250 mm		250 mm		300 mm	
Type of gas	G20	G31	G20	G31	G20	G31	G20	G31	G20	G31
MODELS	120	2 to 52	--	--	3 to 39	--	--	--	--	--
	140	7 to 39	--	3 to 94	4 to 38	--	--	--	--	--
	180	--	--	10 to 29	--	1 to 100	4 to 73	--	--	--
	225	--	--	--	--	1 to 100	3 to 65	--	--	--
	275	--	--	--	--	--	--	4 to 99	4 to 61	--
	320	--	--	--	--	--	--	5 to 81	6 to 53	--
	390	--	--	--	--	--	--	--	--	2 to 100
	450	--	--	--	--	--	--	--	--	2 to 100

IMPORTANT:

The above values are provided for information purposes only. It is important to check them with a calculation.

IMPORTANT:

The weight of flue-gas ducts must not be supported by the part connecting to the boiler.

4.10.2. Connection to a B23P chimney

Type B23P connection:

Air coming from the boiler premises, extraction of gases through the roof via a pressurised duct.

WARNING:

Check that there are top and bottom ventilations in the boiler premises, that they comply with applicable regulations and that they are not obstructed.

IMPORTANT:

For the B23P type connection, it is **MANDATORY** to use ducts which have pressurised duct certification, such as **CONDENSOR (Poujoulat)** or rigid or flexible **CHEMILUX CONDENSATION (Ubbink)**.

IMPORTANT:

The duct extracting combustion products must be sized using the parameters provided in the table in paragraph 3.3. Depending on the duct's actual configuration, a calculation is necessary to check that the pressures at the boiler outlet do not exceed the maximum normative values authorised (200 Pa). Values corresponding to the 50/30°C regime are to be used for this calculation.

Cascade installation case

In this case, where boilers with different powers are connected, the most powerful models must be closest to the chimney.

The boiler is equipped with an internal check valve smoke diverter, replacing any other external and functionally identical system.

Sizing recommendations on the basis of a POUJOLAT system (Condensor type):

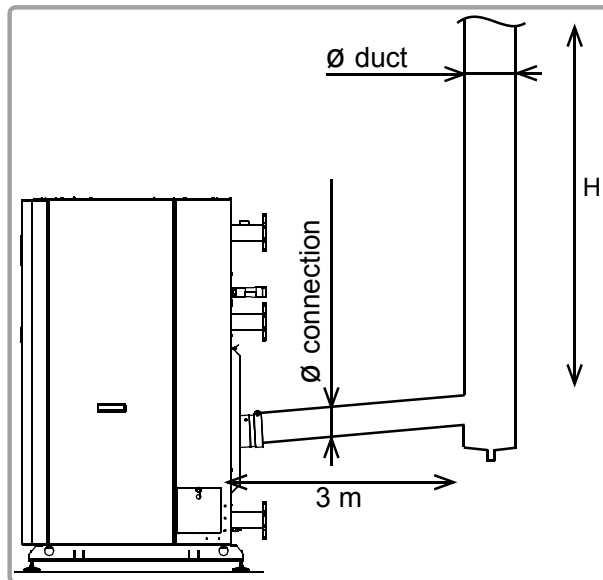

figure 18 - B23P (Poujoulat) sizing recommendations

Height of flue-gas duct H in linear metres (lm)
(operating at 50/30°C)

Ø connection Ø duct	150 mm		180 mm		200 mm			
	130 mm	150 mm	180 mm	200 mm				
Type of gas	G20	G31	G20	G31	G20	G31	G20	G31
MODELS	120	79	60	--	--	--	--	--
	140	87	39	--	--	--	--	--
	180	--	--	74	23	--	--	--
	225	--	--	69	20	--	--	--
	275	--	--	--	--	100	73	--
	320	--	--	--	--	100	64	--
	390	--	--	--	--	--	--	100
	450	--	--	--	--	--	--	100



IMPORTANT:

The above values are provided for information purposes only. It is important to check them with a calculation.



IMPORTANT:

The weight of flue-gas ducts must not be supported by the boiler.

Sizing recommendations on the basis of a UBBINK system:

Using a Ubbink duct in PPTL Ø160 requires a Male 150 / Female 160 adaptor (reference 041432) at the boiler outlet.

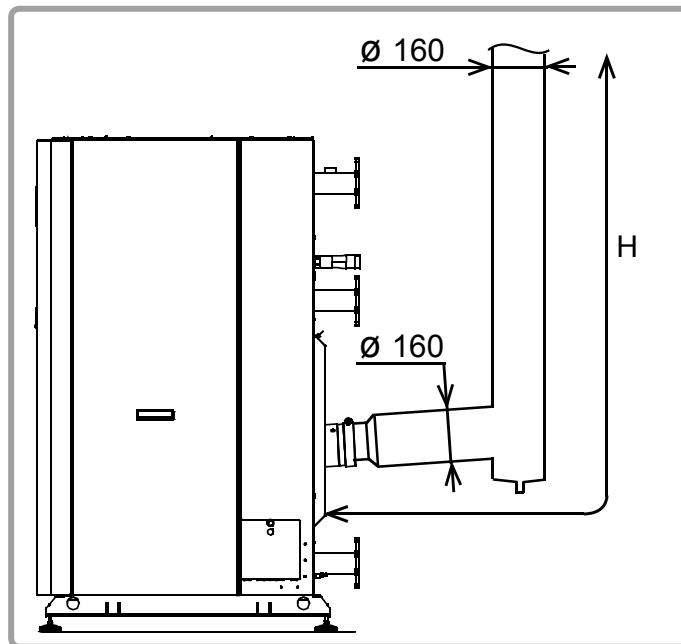

figure 19 - B23P (Ubbink) sizing recommendations

Height of flue-gas duct H in linear metres (lm)
(operating at 50/30°C)

duct	Ø 160 mm			
	rigid		flexible	
Type of gas	G20	G31	G20	G31
MODELS	120	100	100	86
	140	100	100	86
	180	64	32	30
	225	58	40	28



IMPORTANT:

The above values are provided for information purposes only. It is important to check them with a calculation.

4.10.3. Rules for installing air vent terminals

Please refer to national standards and regulations.

4.10.4. Connection to a C13 or C33 air vent

Type C13 connection:

Air inlet and gas extraction via separate ducts connected to a horizontal concentric terminal (air vent).

Type C33 connection:

Air inlet and gas extraction via separate ducts connected to a vertical concentric terminal.



IMPORTANT:

Connecting a VARMAX boiler in C13 or C33 configuration requires use of the "Terminal kit" comprising a terminal, a dual-flow adaptor and a male adaptor Ø150 / female adaptor Ø160 (reference 041421).

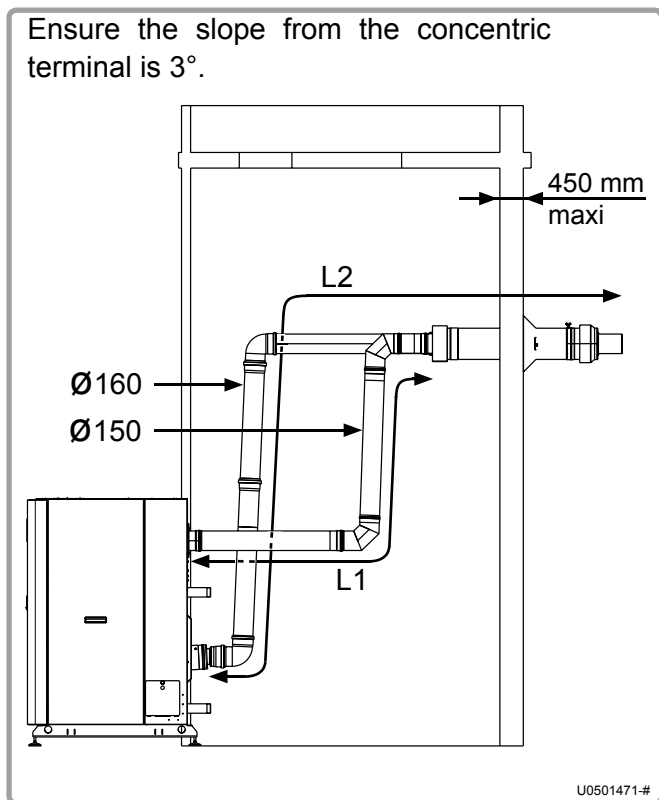

figure 20 - Type C13 connection

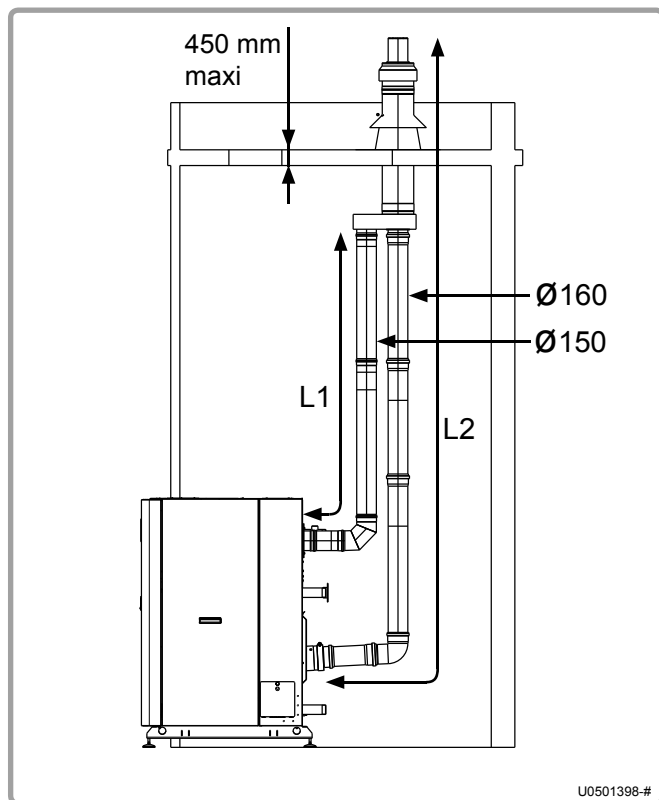

figure 21 - Type C33 connection

The table below shows the maximum straight lengths authorised for air and flue-gas ducts.

	MODELS			
	120	140	180	225
L1 (air)	16.5 lm		13.5 lm	
L2 (flue-gases)	17.5 lm		14.5 lm	

The lengths indicated include the lengths of the concentric terminal.

In addition, in the duct length calculation, the following equivalences must be used;

- 90° elbow = 1.5 m of straight duct
- 45° elbow = 0.8 m of straight duct

The terminal's installation must comply with the rules in § 4.10.3, page 30.

To facilitate mounting of flue-gas ducts (PPTL), coat the joints with liquid soap or a suitable grease (provided in the "terminal kit").



IMPORTANT:

The weight of the ducts (air and flue-gas) must not be supported by the boiler's connecting parts.

4.10.5. Connection to a C53 air vent

Type C53 connection:

Air inlet and gas extraction via 2 separate ducts.



IMPORTANT:

Connecting a VARMAX boiler in a C53 configuration requires the use of accessory kits.

The table below gives the reference of the available kits depending on the boiler model and the maximum straight lengths authorised for the air and flue-gas ducts.

	MODELS							
	120	140	180	225	275	320	390	450
Accessory kit reference	041422		041422		041423		041424	
L1 (air)	10 lm		8 lm		10 lm		10 lm	
L2 (flue-gas)	40 lm		39 lm		40 lm		40 lm	
Ø A (air duct)	150 mm		150 mm		180 mm		180 mm	
Ø F (flue-gas duct)	160 mm		160 mm		180 mm		200 mm	

The lengths given include the lengths of the flue-gas terminal but do not include the air terminal (measure taken on the outside of the wall).

In addition, in the duct length calculation, the following equivalences must be used;

For ducts with diameters 150 mm and 160 mm:

- 90° elbow = 1.5 m of straight duct
- 45° elbow = 0.8 m of straight duct

For ducts with diameters 180 mm and 200 mm:

- 90° elbow = 2 m of straight duct
- 45° elbow = 1.1 m of straight duct

The flue-gas terminal's installation must comply with rules in § 4.10.3, page 30.

Ensure the slope towards the boiler is at least 3° (flue-gas side). On the air duct side, adjust a slope to the outside to avoid the risk of rainwater in the boiler.

To facilitate mounting flue-gas ducts for models 120 to 225, coat the joints in liquid soap or a suitable grease (provided in the "terminal kit").

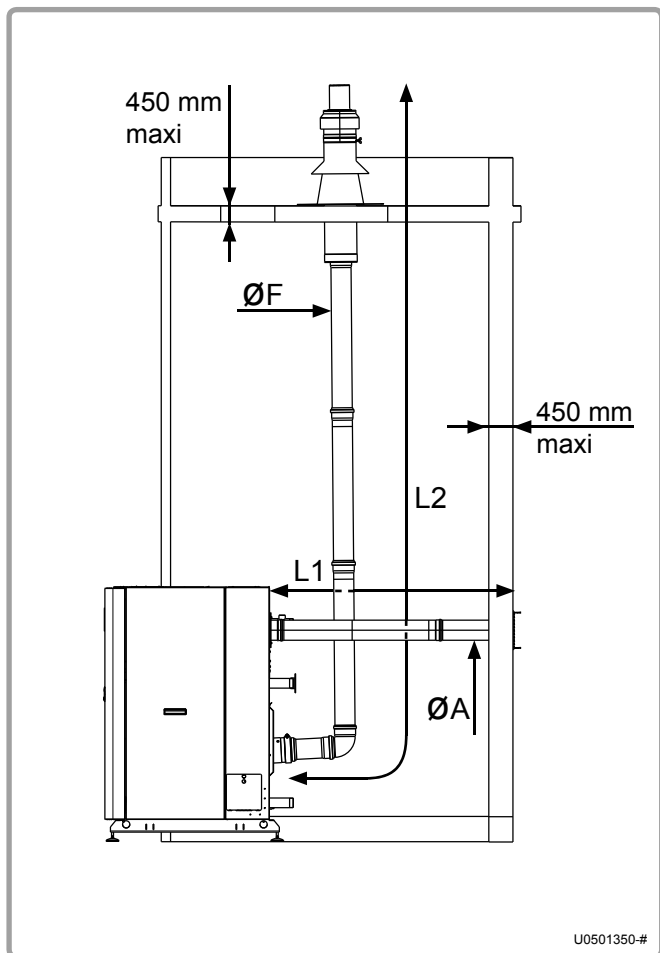

figure 22 - Type C53 connection (VARMAX models 120 to 225)

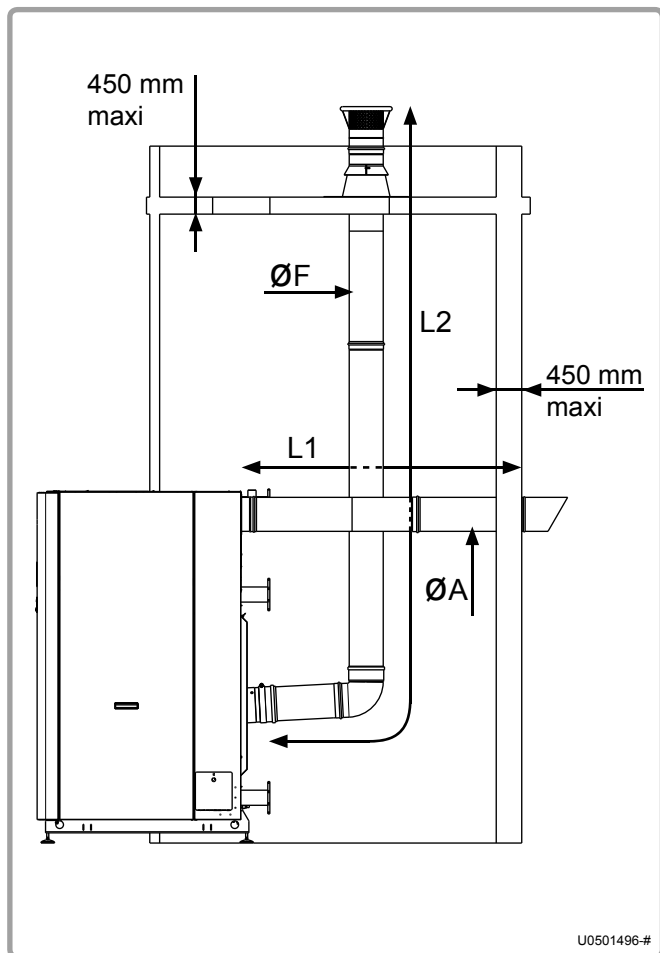

figure 23 - Type C53 connection (VARMAX models 275 to 450)



IMPORTANT: The weight of flue-gas ducts must not be supported by the boiler.

4.11. Hydraulic connection

The presence of an integrated irrigation pump in the boiler and an intelligent control logic enables optimal operation up to IUP/30 (IUP = Instant Useful Power expressed in Th/h - 1Th/h = 1.163 kilowatts).

Below this throughput of IUP /30, the boiler will continue to operate, but will gradually lose power (boiler stops below IUP /46).

In connector sleeves 3 and 4, there is no minimum throughput constraint on the condenser.

In the main heat exchanger, as in the condenser, you must ensure that you never exceed the throughput prescribed in section 3.4 (boiler nominal useful power / 10).

Sizing the pipes connecting the boiler to the installation must be done carefully, to minimise the pressure losses and so avoid oversized circulating pumps.

In some cases the diameter of the connection pipes will be greater than the diameter of the boiler tapplings. The diameter can then be usefully increased after the union connectors, the stop valves, and/or the hydraulic balancing valves.

VARMAX boilers are equipped with the following elements:

- main exchanger drain valve,
- condenser drain valve.

It is mandatory to fit the boiler and its installation with the following elements:

- isolating valves on the flow and return tapplings,
- an expansion vessel,
- an efficient bleed device,
- a safety valve set to 6 bar,
- A shut-off on the boiler's fill circuit in relation to the main supply.

VARMAX boilers are available with 2/3 tapplings or 4 tapplings. It is not possible to transform a version with 2/3 tapplings into a version with 4 tapplings and vice versa.

4.11.1. Boiler with 2 or 3 tapplings

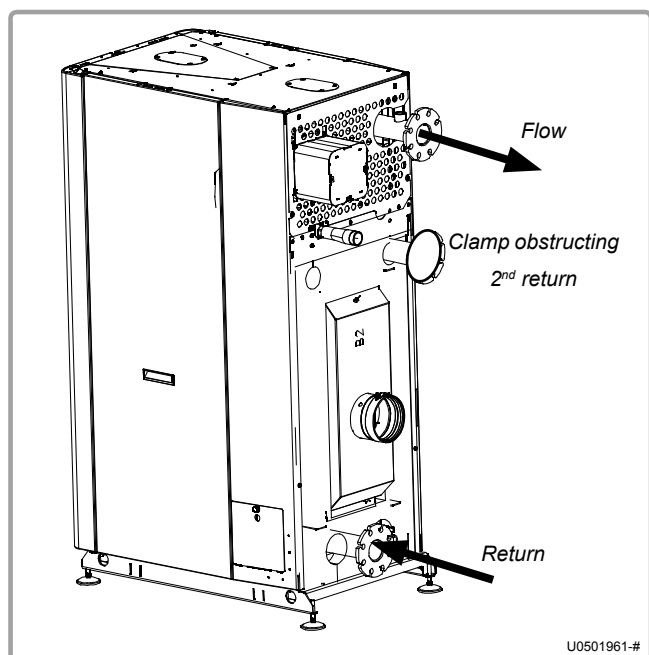

figure 24 - Connection with 2 tapplings

2 tapplings

If all the circuits have the same return temperatures, the return tapping located in the lower part must be used.

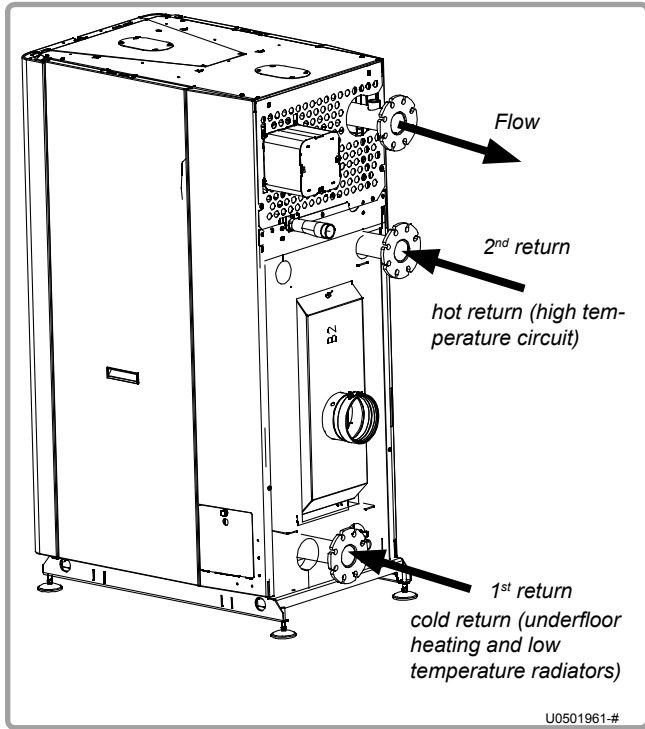

figure 25 - Connection with 3 tappings

3 tappings

VARMAX boilers are fitted with 2 returns and an optimised internal water circuit allowing effective separation of high temperature returns (coming from DHW preparation circuits, radiators, etc.) from low temperature circuits (underfloor heating circuits, low temperature radiator circuits, etc.). This circuit separation encourages the condensation of flue-gases in the lower part of the condenser throughout the year, and therefore considerably increases the boiler's performance.

To use the 2nd return, the clamp obstructing the tapping must be removed.

4.11.2. Boiler with 4 tappings

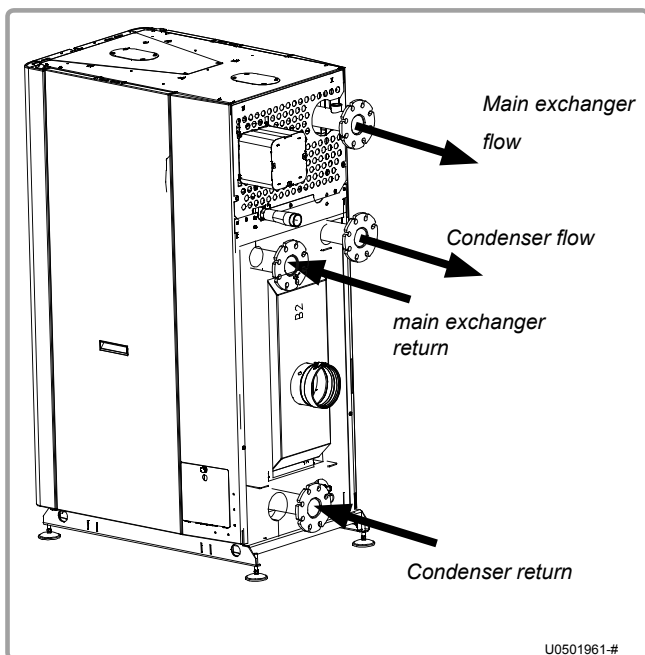

figure 26 - Connection with 4 tappings

VARMAX boilers are fitted with 2 internal water circuits allowing separation of high temperature returns (coming from DHW preparation circuits, radiators, etc.) from low temperature circuits (underfloor heating circuits, low temperature radiator circuits, etc.).

In some installations, additional improvement may be obtained using 4 tappings. This separates the condenser (low temperatures) from the main exchanger (high temperatures).

There are no throughput constraints regarding the condenser.



WARNING:

Do not connect DHW (domestic hot water) or swimming pool water to the condenser circuit.

4.11.3. Condensate removal

Removal to the drains, via a drain hopper, using a P.V.C tube (minimum diameter 32 mm) is mandatory because the condensates are acidic and thus aggressive (pH between 3 and 5).

Use a sufficient slope of 3% to ensure correct flow of the condensates.



WARNING:

Neutralise these condensates before removal according to regulations in force.

4.12. Gas connection

Before installing the boiler, it is necessary to clean the inside of the installation's gas line (metallic particles, soldering residue, etc.). This helps to improve the product's longevity.

Before commissioning the boiler, check that the natural gas supply pressure corresponds to the boiler's nominal pressure mentioned on the identification plate.

Before feeding gas to the installation, ensure that the different connections are correctly made and gas tight.

In particular, check the presence of a removable connector between the isolating valve and the boiler gas supply tapping.

The value read at the gas valve input must be between the limits indicated in the table in chapter 2.5, page 11 for the type of gas used.



WARNING:

**The boiler's gas line connection must not be subject to any mechanical stress (risk of loss of gas tightness of the gas valve).
Check that the natural gas supply corresponds to the nominal boiler pressure stated on the identification plate.**

4.13. Electrical connection



DANGER:

Ensure that the general electrical power supply has been cut off before starting any work.



WARNING:

Observe the phase polarity - neutral for electrical connections.



WARNING:

It is mandatory to connect this boiler correctly to earth and to comply with applicable standards for low voltage electrical installations in the United Kingdom.

Provide a two pole circuit breaker upstream of the boiler (distance between contacts: 3.5 mm minimum).

It is strongly recommended to fit the electrical installation with a 30 mA differential protection.

Refer to the instructions of installation and use of the NAVISTEM B3000 boiler command table for information concerning electrical connections to the control panel (characteristics of the electrical power supply, cable section and connection to terminal blocks).

4.13.1. Control panel

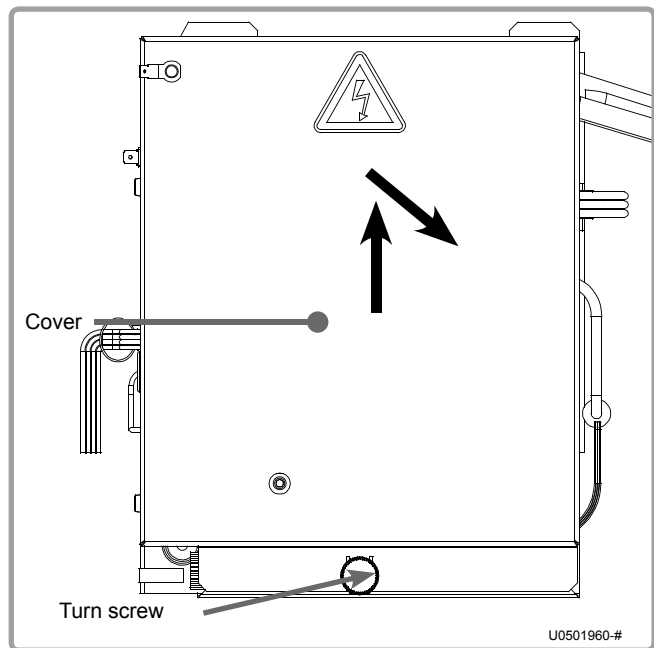

figure 27 - Opening the electrical box

To access the control panel, open the casing doors on the front of the boiler.

The control panel is on the upper front left of the boiler.

Unscrew the turn screw at the bottom of the cover.

Lift up the cover and pull backwards.

4.13.2. Cable bushing

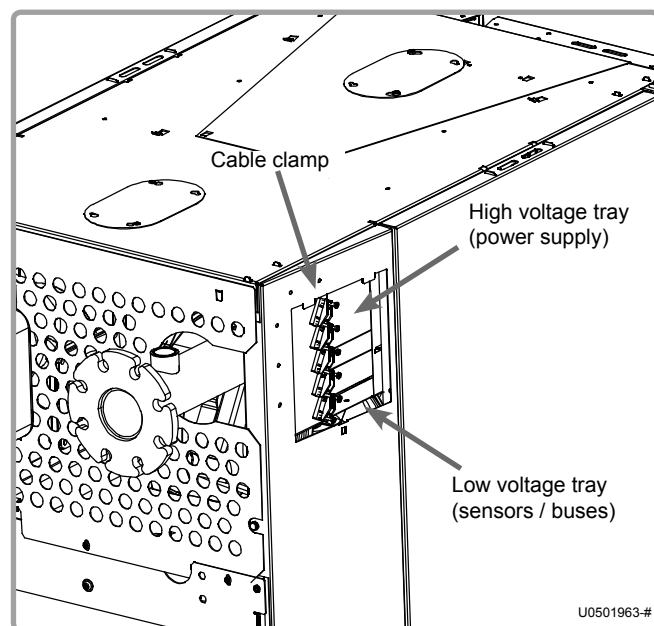

figure 28 - Electrical cable bushing

Use the cable trays located on the top left of the boiler to insert the connection cables:

- The **upper** tray must be reserved for the **power connections** (boiler power supply, alarm feedback or circulating pump control).
- The **lower** tray is dedicated to **signal connections** (sensors, communication bus, etc.).

Use the cable clamp located at the inputs to the trays to lock the cable mechanically.

4.13.3. Connection of the boiler command table to the terminal blocks

To connect the boiler command table, refer to the relevant instructions of installation and use.



ATTENTION :

For connection, comply with the wiring diagram, in particular the phase, neutral and earth polarities.

4.13.4. Connection of AVS75 extension module(s) (optional)

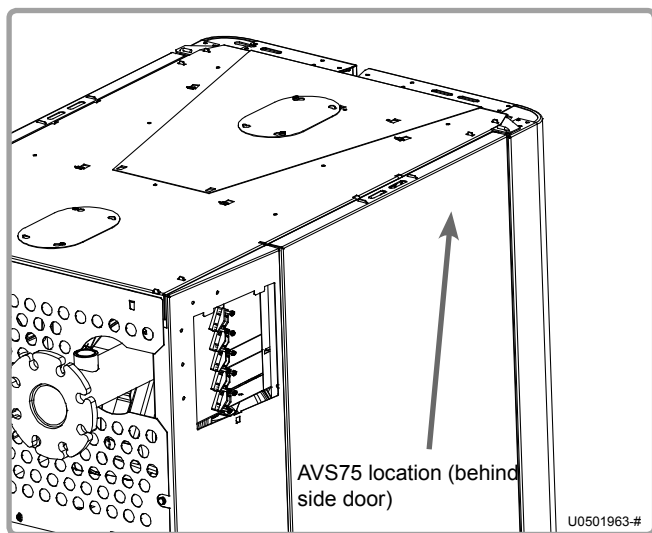

figure 29 - AVS75 location

To install AVS75 module(s) (3 max), refer to the instructions provided with the accessory (reference 059751).

4.13.5. Connection of OCI345 communication module (optional)

To install the OCI345 module, refer to the instructions provided with the accessory (reference 059752).

4.13.6. Fuses

The VARMAX boiler is fitted with 4 fuses on the boiler command table (refer to the sticker on the protective cover for their locations and characteristics). 3 spare fuses are also available on the boiler command table.

4.13.7. Electrical wiring diagram

Refer to the paragraph 2.3 of the NAVISTEM B3000 manual should you require further information on the characteristics of borniers.

	Cascade flow sensor
	Cascade return sensor
	DHW sensor
	External sensor
	Input prog. client: 0...10V
	Input prog. client. contact

	Room sensor
	Boiler flow sensor
	Boiler return sensor
	Flue-gas sensor
	Alarm relay

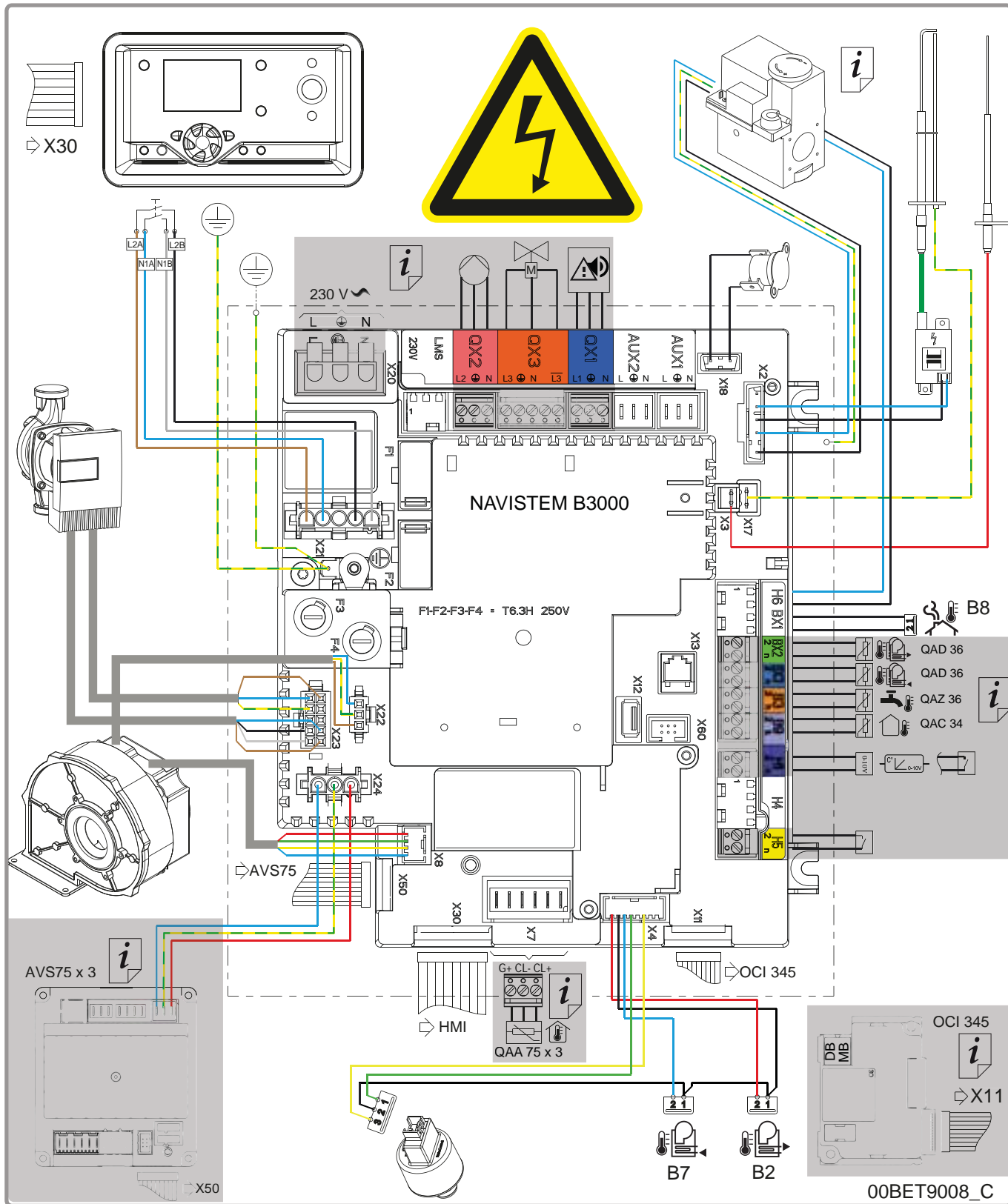

figure 30 - Electrical wiring diagram

5. COMMISSIONING

5.1. Unlocking the boiler



WARNING:

During commissioning, the unlocking of the boiler can only be achieved if the hydraulic system is compliant with the recommendations mentioned in the hydraulic diagrams (see section 8.3, page 54). The person in charge of this operation must ensure such compliance.

Unlocking the temperature:

Modify parameter 2212 from 70° C to the desired value (Maximum 85°C).

Unlocking the power:

Increase the value of parameter 9529 up to the value of parameter 9530 (corresponding with the nominal power of the boiler).



WARNING:

Adjusting the boiler to operate using propane results in the modification of parameter 9529; the boiler power locking function is therefore no longer active.

Parameter 9529 value	MODELS							
	120	140	180	225	275	320	390	450
power locked	4610	5300	3180	3870	3360	3930	3440	3900
power unlocked	6490	7460	4410	5400	4620	5450	4810	5480

5.2. Pre-commissioning checks

For a cascade installation, check the hydraulic balance of the boilers.

Check that pressure when cold is at least 1 bar.

If this is a boiler room renovation, ensure that flushing and if necessary silt removal from the installation have been correctly done (see paragraph 1.5, page 7 of these instructions).

Check the flue-gas connections depending on the type of chimney (refer to paragraph 4.9, page 24).

Check that the gas pressure and type are suitable for the products.



DANGER:

It is forbidden to use water containing glycol.



WARNING:

If connecting CHIMNEY B23 or B23P, it is **COMPULSORY** to fit the air filter supplied with the boiler.

5.3. Commissioning

Before being packed up, all boilers are tested in the factory operating on group H natural gas (type G20), during which all settings are made.

For commissioning, carry out the following operations:

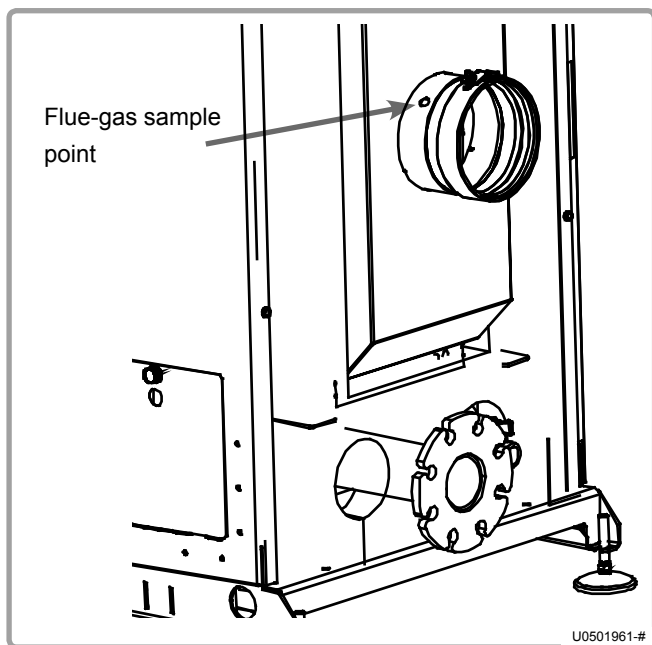

figure 31 - Taking a sample

1. Switch on the main power.
2. Create a request for heat via the comfort mode using the customer interface (see chapter "3 - Interface utilisateur" of the LMS boiler command table instructions).
3. After starting up the burner, check the gas tightness of the gas line connections using a foaming product. Check combustion health using a flue-gas analyser via a sample taken from the flue outlet (see diagram opposite).

CO₂ value range:

G20:

at Qmin: 8,3 % < CO₂ < 8,7 %

at Qmax: 8,8 % < CO₂ < 9,2 %

G31:

at Qmin: 9,8 % < CO₂ < 10,2 %

at Qmax: 10,4 % < CO₂ < 10,8 %

4. Adjust the boiler setting (refer to the table summarising customer parameters at the end of this manual).



WARNING:

Any work on a sealed element leads to loss of warranty.

6. POST-COMMISSIONING CHECK

6.1. Condensate removal

Check that the removal of condensates is not obstructed, on both the boiler side and the pipe side

6.2. Gas supply

Check that the gas pipe diameter is correctly sized:

It is necessary to stop all the boilers together abruptly using the boiler room main circuit breaker to check that the gas pressure regulator safety device is not triggered.

If this is triggered, the gas pipe is undersized. After this operation, reengage the circuit breaker. The boilers must start automatically, if not, consult the supplier of the gas pressure regulator.

7. MAINTENANCE OPERATIONS

There are two types of maintenance operations:

- yearly maintenance
- in-depth maintenance every 3 years.

The table below shows which actions to undertake depending on the type of maintenance to be performed.

In all events, these operations must be performed by a qualified professional.

Before carrying out the following operations:

- Switch off the main power
- Close the gas supply shut-off valve.



DANGER:

This boiler's earth bonding is ensured with connecting cables (green/yellow) and specific attachment screws. During any dismantling work, make sure you reconnect the cables concerned; it is **IMPERATIVE** to reuse the original attachment screws.

No. of paragraph to consult		Maintenance	
		every year	every three years
7.2	Verification of the boiler's environment	X	
7.3	Replacing the air filter matting	X	
7.4	Verification of ignition and ionisation electrodes	X	
7.5	Siphon cleaning	X	
7.6	Checking the combustion circuit's gas-tightness	X	
7.7	Checking combustion quality	X	
7.9	Gas filter cleaning	X	
7.10	Cleaning exchangers and changing of seals on service doors		X
7.11	Check the condition of the gas manifold coating Cleaning the burner and changing the seals		X

7.1. Boiler draining

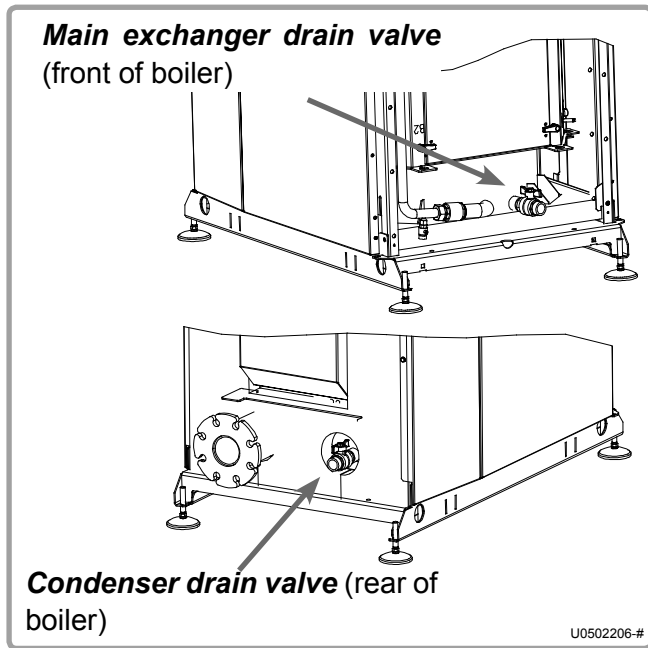

figure 32 - Drain valves

- Close the shut-off valves of the flow and return tapings.
- Connect the drain valves (main exchanger and condenser) to the drain with a suitable hose.
- Create an air intake on the "main exchanger" flow nozzle (open the safety valve).
- Open the drain valve.

7.2. Verification of the boiler's environment

Before carrying out any maintenance work, it is necessary to perform a certain number of checks concerning the installation's use.

- Water pressure: check that the water pressure is higher than 1 bar when cold.
- Read the makeup water meter. This operation helps to identify any hydraulic leaks. If consumption of makeup water changes, seek the cause and repair.

7.3. Replacing the air filter matting



DANGER:

To make sure this task is performed in safety, switch off the boiler and cut off the upstream power.



DANGER:

Use personal protective equipment (mask and gloves) to remove the used air filter.



INFORMATION:

The air filter is only present on boilers connected to a B23 or B23P chimney.



INFORMATION:

The air filter is an important element of the boiler. It limits the burner and the exchangers becoming sooty. Changing it regularly (at least every year) makes burner and exchanger cleaning operations considerably easier.

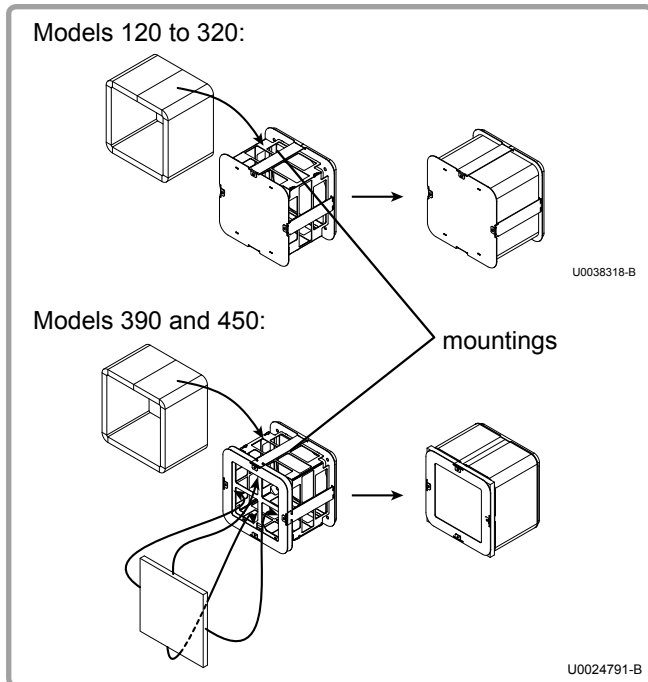

figure 33 - Filter matting

- Remove the used filter matting (no tool required).
- **Be careful not to let any dust or other foreign bodies enter the air duct (see opposite).**
- Insert the new rectangular filter matting between the filter's protective grille and the mountings (see opposite).

Ensure that the link between both ends of the matting is under one of the mountings.

- For models 390 and 450, insert the square filter cloth on the back gate of the filter.

7.4. Verification of ignition and ionisation electrodes

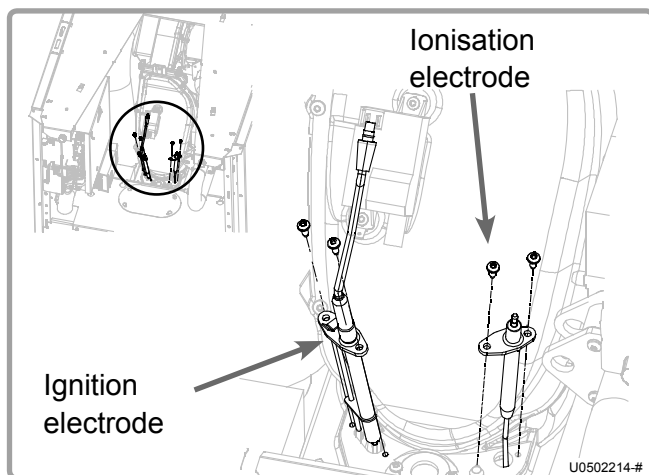

figure 34 - Position of electrodes

Electrode removal

Unscrew the two M4 Torx screws holding the electrode that needs to be removed.

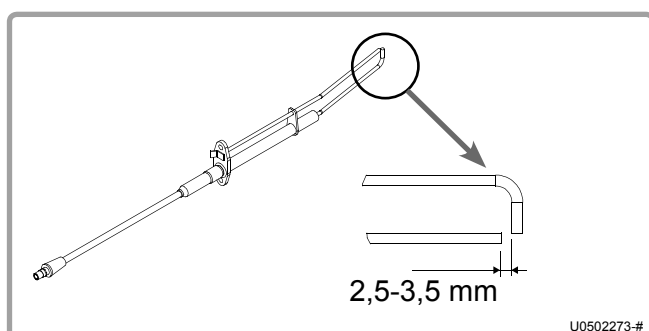

figure 35 - Spacing

If necessary and if there is a large amount of oxidation, clean the electrodes by rubbing them with an emery cloth.

Check the space between the ignition electrode and the ground electrode (see diagram opposite). It must be between 2.5 and 3.5 mm. If this is not the case, replace the electrode.

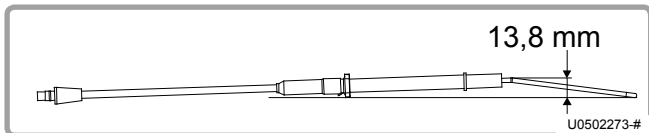

figure 36 - Geometry

Check the geometry of the arc electrode:
If deformed more than ± 3 mm, replace the electrode.

Re-assemble the electrode block(s). Tightening torque of the block fixing screws = 2.5 N.m.

7.5. Siphon cleaning

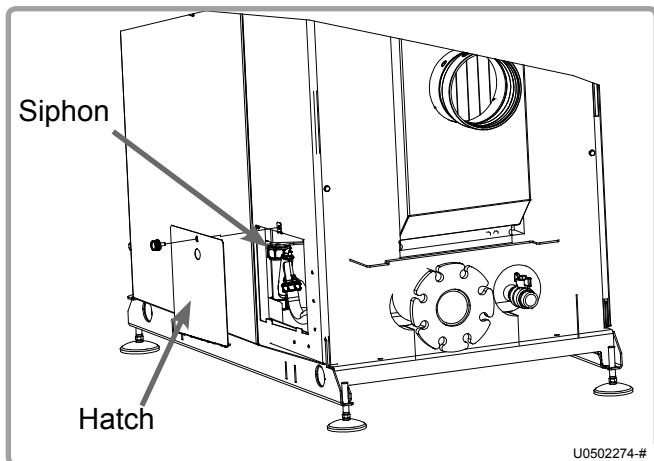

figure 37 - Siphon

Check the siphon and clean if necessary. The siphon must be located between the main exchanger and the condenser on the right-hand side (it can be accessed via the hatch without removing the side panel).

To do this:

- Dislodge the siphon by pulling it downwards.
- Clean with water.
- Re-assemble the siphon after checking the presence and the possibility of free movement of the float (ball). Also check that the seal is not damaged.

7.6. Checking the combustion circuit's gas-tightness

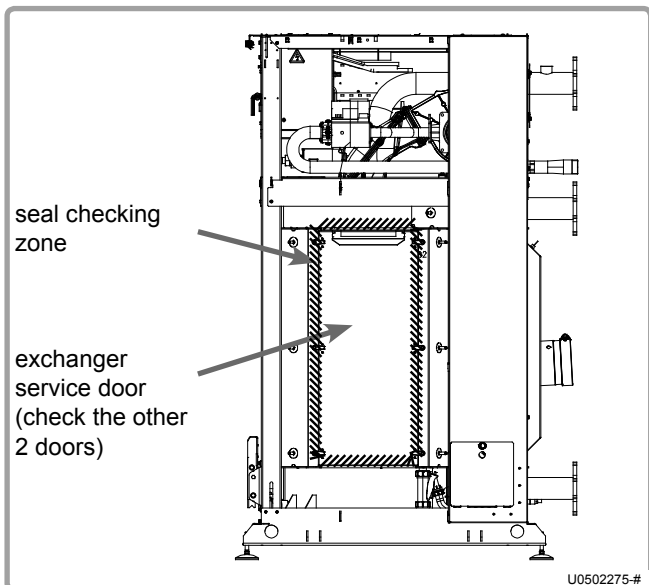

figure 38 - Gas-tightness of the service door

Check the gas-tightness of the 3 service doors using the foaming product. The areas to check are shown on the diagram opposite.

The check must be performed when the boiler is off, but with the ventilator operating at its maximum speed (obtained by disconnecting the PWM signal connector).

If a leak is detected, replace the seal with the appropriate kit.

It is recommended to replace the seals each time the exchanger service doors are removed. If they are not replaced, do not cross the doors when re-assembling.

7.7. Checking combustion quality

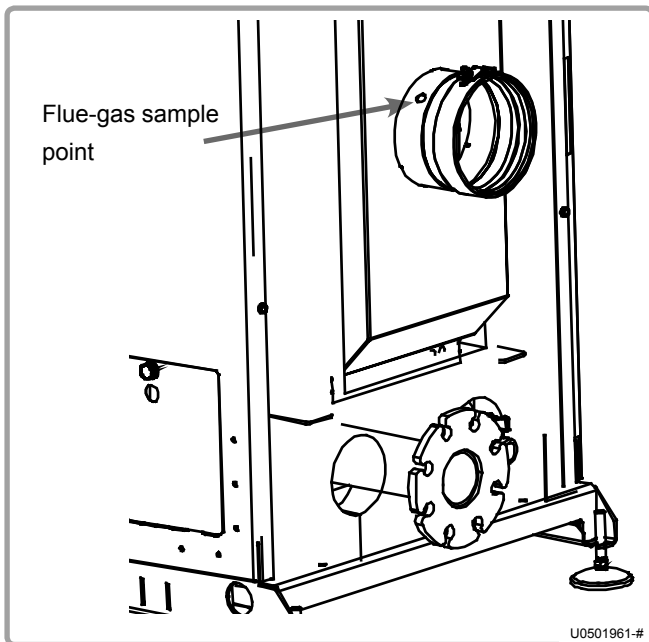

figure 39 - Sample taking

This check is performed using a calibrated combustion case. To do this, insert the measuring stick into the flue outlet (see diagram opposite).

The boiler's starting temperature must be above 70°C.

Do not forget to re-position the stopper on the orifice from where the sample is taken afterwards.

For the G20, the CO₂ content measured in these circumstances must be between 8.3% and 8.7% at Qmini (0% on display) and between 8.8% and 9.2% at Qmaxi (100% on display).

If this is not the case, it is necessary to alter the setting of the gas valve (see next paragraph).

After this check, it is necessary to either take a measurement of the "gas" throughput or the ΔP valve. These measurements check the state of soiling of the combustion circuit (burner, body, exchanger(s)).

For the G31 (relevant modls only), the CO₂ content measured in these circumstances must be between 9.8% and 10.2% at Qmini (0% on display) and between 10.4% and 10.8% at Qmaxi (100% on display).

If this is not the case, it is necessary to alter the setting of the gas valve (see next paragraph).

After this check, it is necessary to either take a measurement of the "gas" throughput or the ΔP valve. These measurements check the state of soiling of the combustion circuit (burner, body, exchanger(s)).

For installations with B23 and B23P, we recommend you take this measurement using a new air filter.

The measurement must be done for a duration of more than 3 minutes to obtain a sufficiently precise measurement.

If the gas throughput is less than 20% in relation to the value indicated in paragraph 3.3, page 15, it is necessary to clean the main exchanger and the burner (see § 7.10 and 7.11).

If you choose to take a measurement of the ΔP valve, refer to the next paragraph to find out how to do it. If the value measured is lower than the values defined in the table on page 49, it is necessary to clean the main exchanger and the burner (see § 7.10 and 7.11).

7.8. Setting the gas valve

This VARMAX boiler has been adjusted in the factory to operate with group H natural gas (type G20) with inlet gas pressure of 20 mbar.



WARNING:

Any work on adjusting the gas valve must be performed by a qualified professional.

The valve must be adjusted with the boiler working at maximum and minimum pressure. To do this, use the operating "Manual operating" mode (see § 3.3.4 of the NAVISTEM B3000 boiler command table instructions), which makes it possible to switch directly to the minimum or maximum value (0% or 100%).

7.8.1. For models 120 and 140

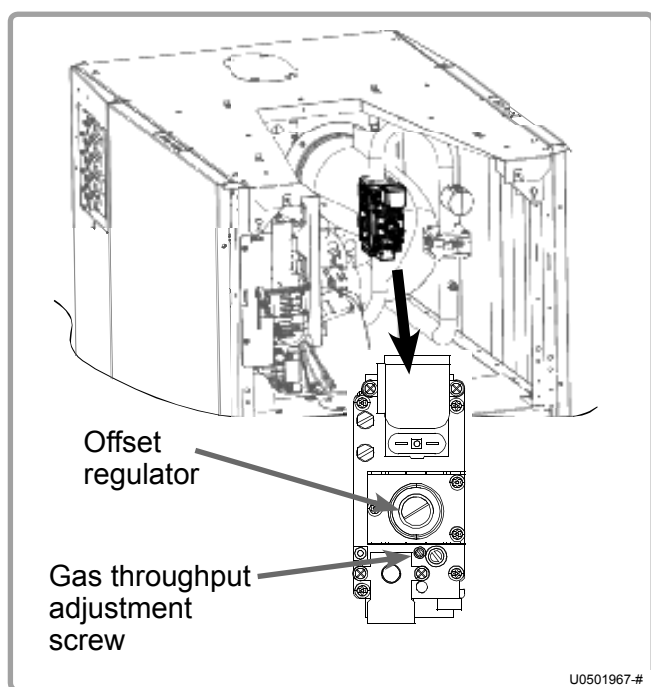

figure 40 - VARMAX gas valve models 120 and 140

Start the burner up at maximum power.

Using the combustion analyser, measure the rate of CO₂ in the flue-gases in the flue outlet (see figure 39).

Check the CO₂ value at Maximum power and, if necessary, manipulate the valve's gas throughput adjustment screw to obtain CO₂ values between 8.8% and 9.2% or between 10,4% and 10,8% (G31).

Move to Minimum power and check that the CO₂ value is between 8.3% and 8.7% (G20) or between 9,8% and 10,2% (G31). If necessary, adjust the Offset regulator by removing the stopper using a flat screwdriver and adjust the screw with a Philips screwdriver.

If changing the setting while on minimum power, switch back to Maximum power and check the CO₂ value again. Repeat until both values conform.

Go back to standard operating mode.

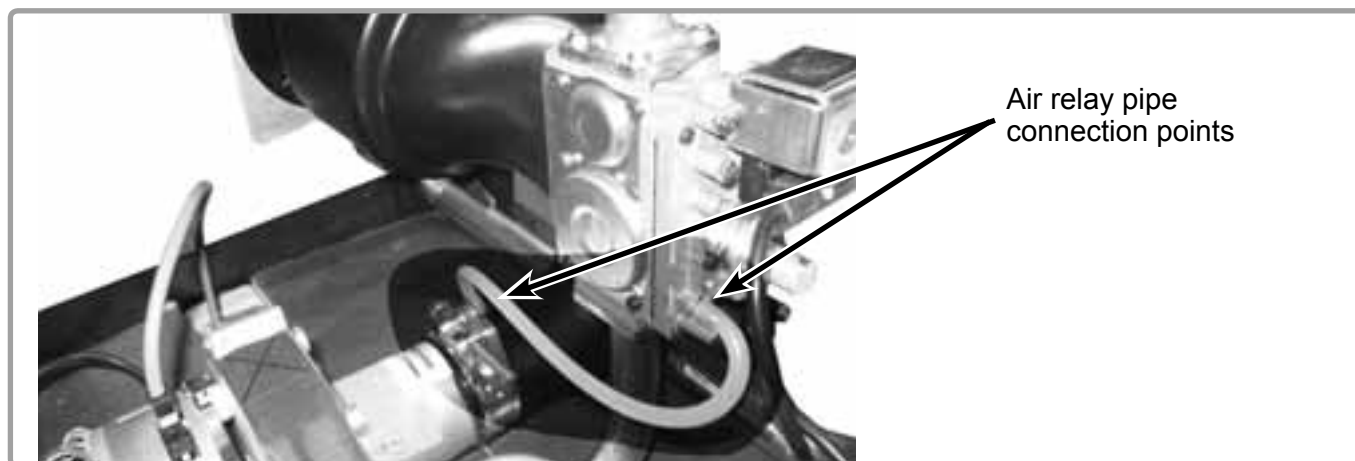

7.8.2. For models 180 to 450

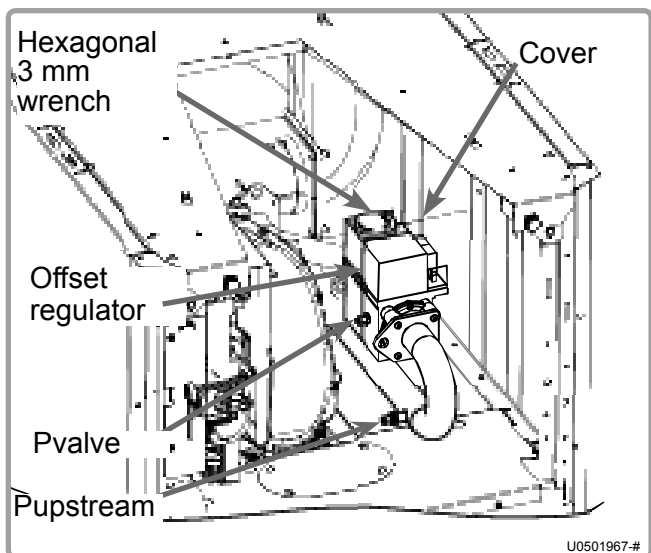

The measurements for setting the valve must be taken using the pressures indicated Pvalve and Pupstream (see diagram opposite).

figure 41 - Gas valve setting

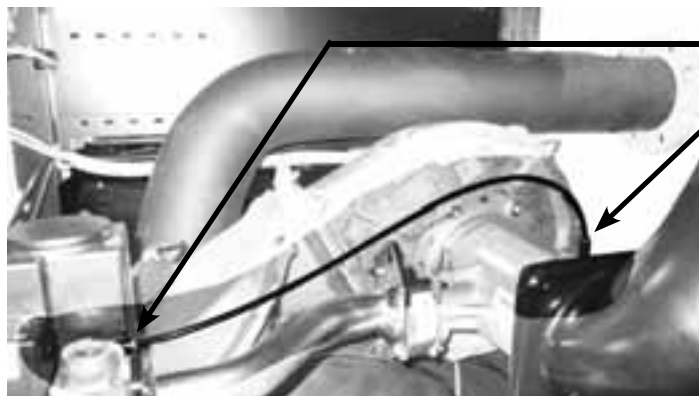

Air relay pipe connection points (Models 180 and 225)

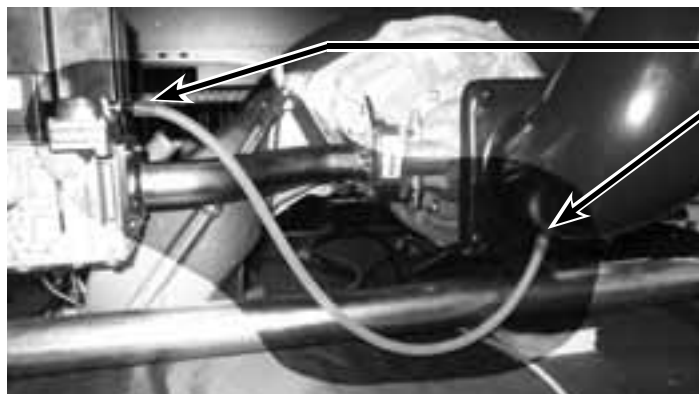

Air relay pipe connection points (Models 275 and 320)

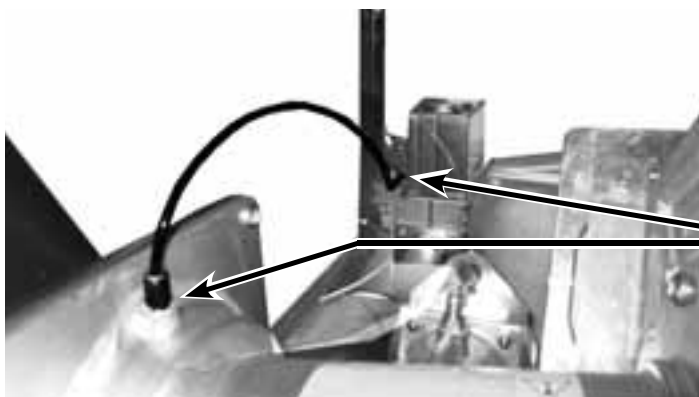

Air relay pipe connection points (Models 390 and 450)

Models	Valve type	Type of gas	$\Delta P_{\text{Schieber}}$ (mbar)
180	VR420	G20	3,8
		G31	1,6
225	VR420	G20	5,9
		G31	2,4
275	VR432	G20	3,6
		G31	1,7
320	VR432	G20	5,2
		G31	2,4
390	VR434	G20	5,4
450	VR434	G20	7,1

$$\Delta P_{\text{valve}} = (P_{\text{upstream}} - P_{\text{valve}})$$

Setting at maximum power:

Start the burner up at maximum power.
 Remove the cover (see figure 41).
 Measure the inlet gas pressure (Pupstream).
 Adjust the valve pressure (Pvalve) taking into account $\Delta P_{\text{valve}} = (P_{\text{upstream}} - P_{\text{valve}})$ given in the table opposite (set the pressure by manipulating the adjustment screw on the top of the valve underneath the black cover, 3 mm hexagonal wrench).
 If necessary, adjust the valve pressure to obtain a CO₂ rate between 8.8% and 9.2% (G20) or between 10,4% and 10,8% (G31).

Then switch to minimum power:

Adjust the offset regulator (see figure 41) to get a CO₂ rate at minimum power between 8.3% and 8.7% (G20) or between 9,8% and 10,2% (G31). Use a flat screwdriver to remove the protective stopper and a Torx wrench to adjust.
 To validate the correct setting of the valve increase to Pmaxi (HMI = 100%) and check the CO₂ rate in the flue-gases in the flue outlet (see figure 39).
 If the setting is not correct, perform the above steps again.

7.9. Gas filter cleaning

- Unscrew the 4 screws that hold the gas filter in place.
- Carefully remove the gas filter.
- Clean the gas filter **ONLY** with a blower.
- Refit the filter and tighten the 4 M5 screws (tightening torque = 5 N.m).

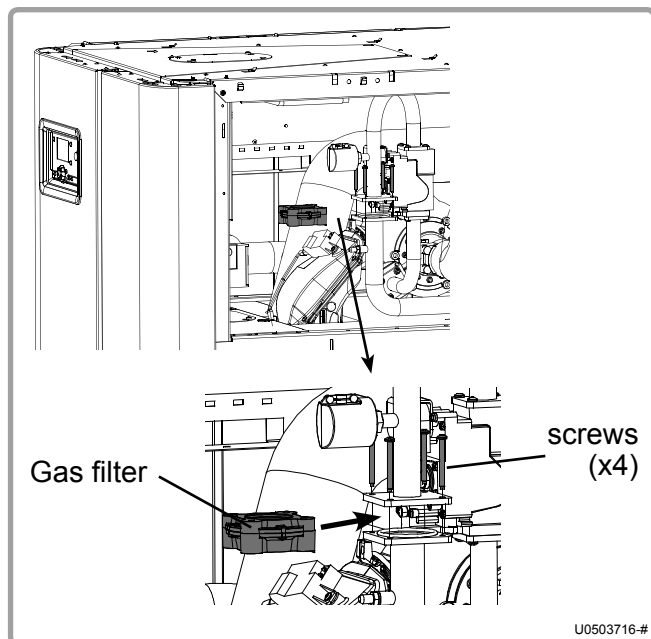

figure 42 - Gas filter on VARMAX 120 and 140

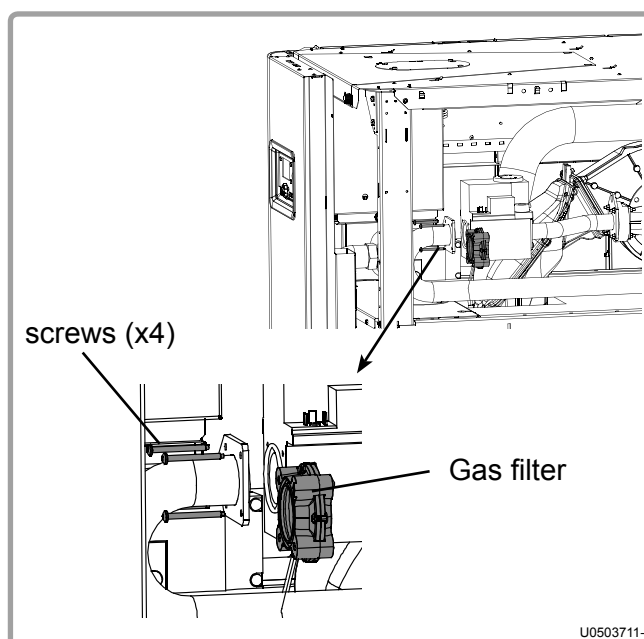

figure 43 - Gas filter on VARMAX 180 to 450



WARNING: Check gas-tightness after refitting.

7.10. Cleaning exchangers and changing seals

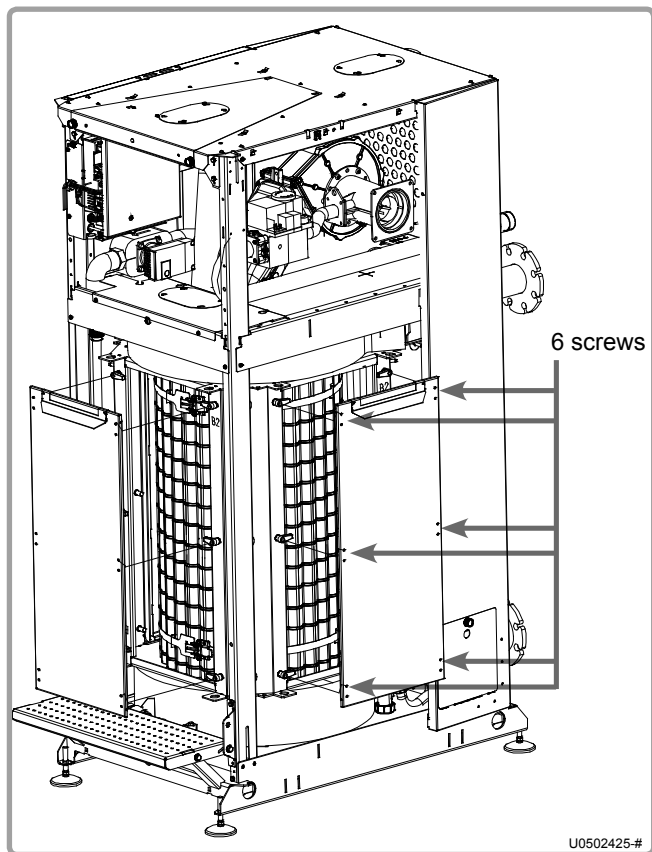

figure 44 - Removal of exchanger doors

Removal of exchanger doors:

- Remove the front and side cladding to access the 3 service doors.
- Using a 13mm wrench, unscrew the service door attachment screws until the tightening bolts turn.
- Then remove the door.
- Repeat for the other 2 service doors.

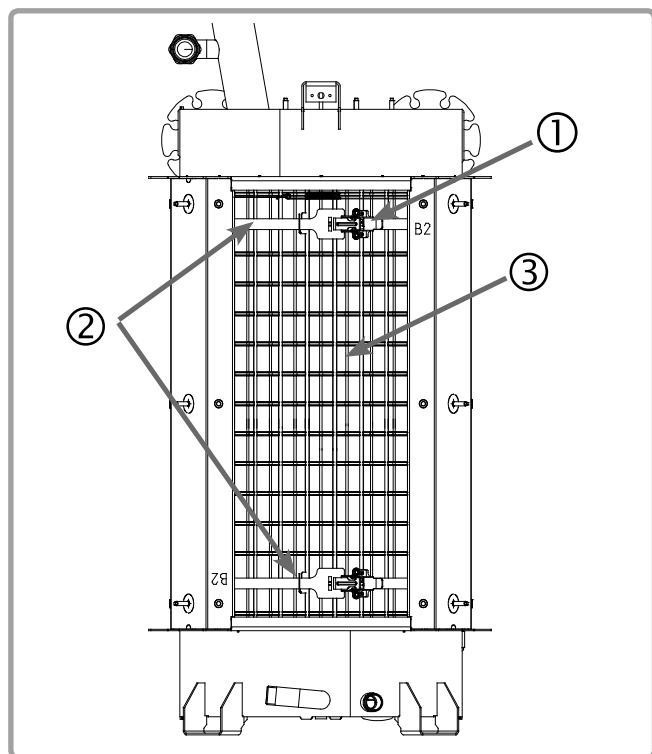

figure 45 - Removal of baffles

Removal of baffles:

- Open the fastenings (mark 1) that close the 2 flue-gas baffle strappings (mark 2).
- Remove the 2 strappings (mark them in some way so that you can refit them in the same order) and then remove the flue-gas baffles (marks 3). Mark these too so that you can refit them in the same position.

Cleaning baffles and exchangers:

- Brush the flue-gas baffles with a stainless steel or plastic brush, **so as not to geometrically deform them.**
- Clean by brushing or if the exchanger is very dirty, wash with water and then dry. If washing with water, be careful of the electrical parts.

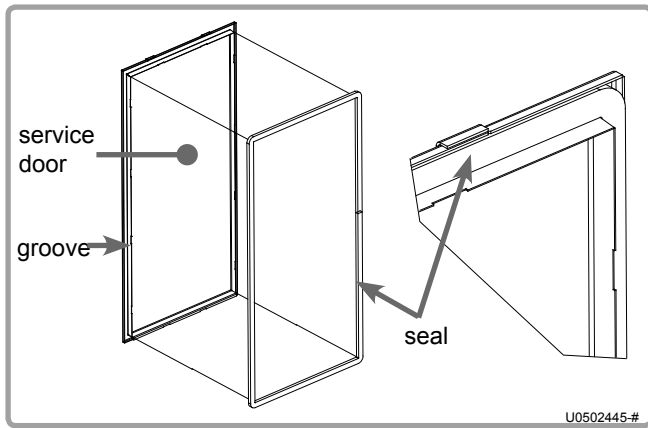

figure 46 - Changing door seals

Changing door seals:

- Remove the seals from their groove and replace with new seals from the maintenance kit (see figure 46).

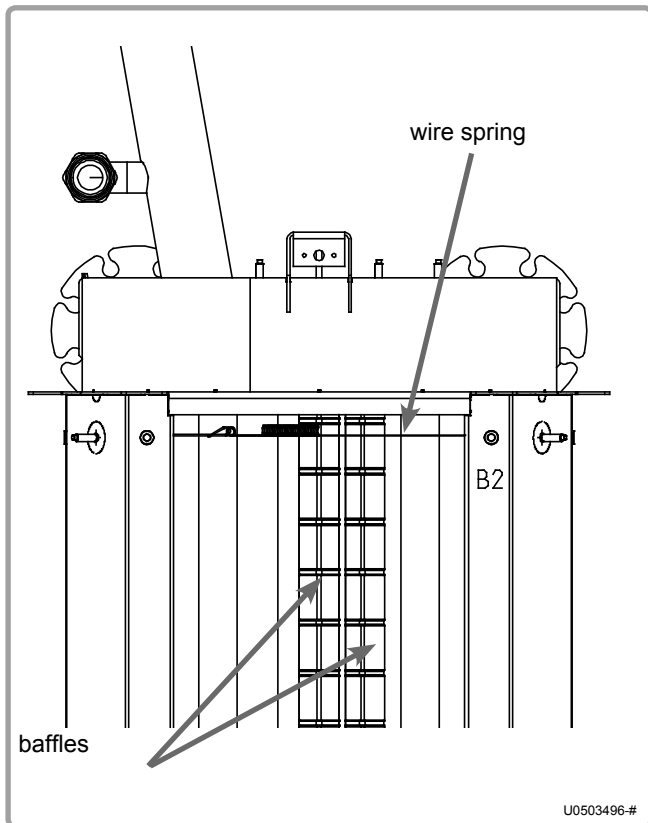

figure 47 - Refitting

Refitting:

- Insert the baffles under the wire spring between the top part of the exchanger tubes (see detail). Replace the baffles holding the strappings (mark 3) as shown on the diagram opposite.
- Position the strappings inside the pins of the baffles holding the strappings.
- Tighten the fastenings and ensure the baffles are correctly fitted to the exchanger tubes and **check that each of the baffles are correctly fitted on the exchanger tubes at their lower and upper ends.**

Note:

It is normal that the baffles are not fitted tightly in the area between the 2 strappings.

Checking gas-tightness:

- After refitting the 3 service doors (tightening torque of screws = 15 N.m), check the gas tightness using the foaming product around the service doors before starting the boiler up again (see chapter 7.6).

7.11. Cleaning the burner and changing the seals

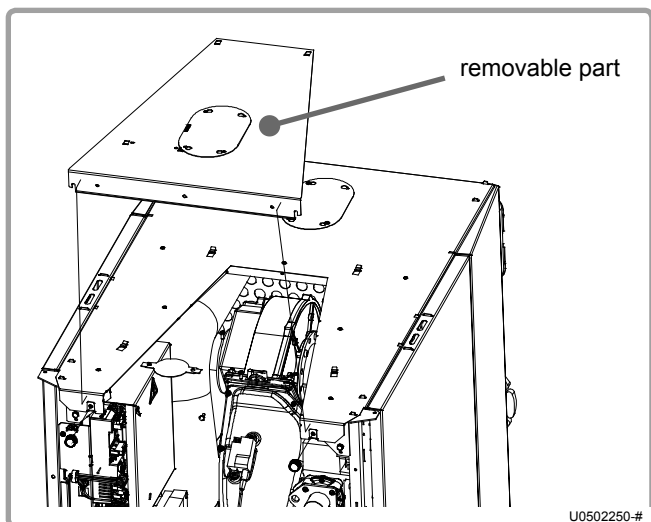

figure 48 - Removable upper door

To facilitate access to the spool piece and then the gas tube, part of the upper door is removable.

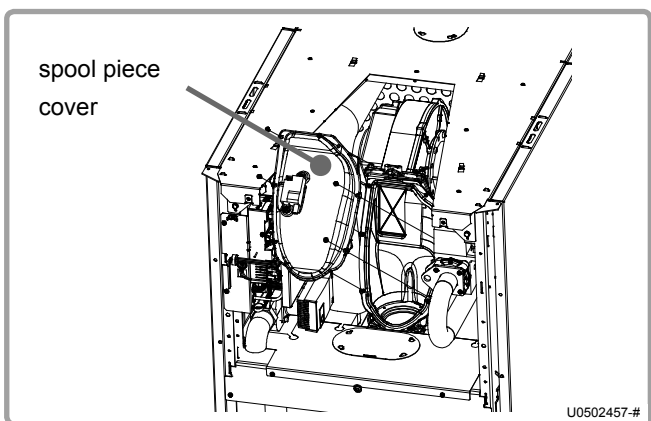

figure 49 - Removal of spool piece cover

Removing the burner tube:

- Remove the 2 electrode blocks before removing the burner tube (see chapter 7.4).
- Unscrew the attachment screws from the spool piece cover to remove it.

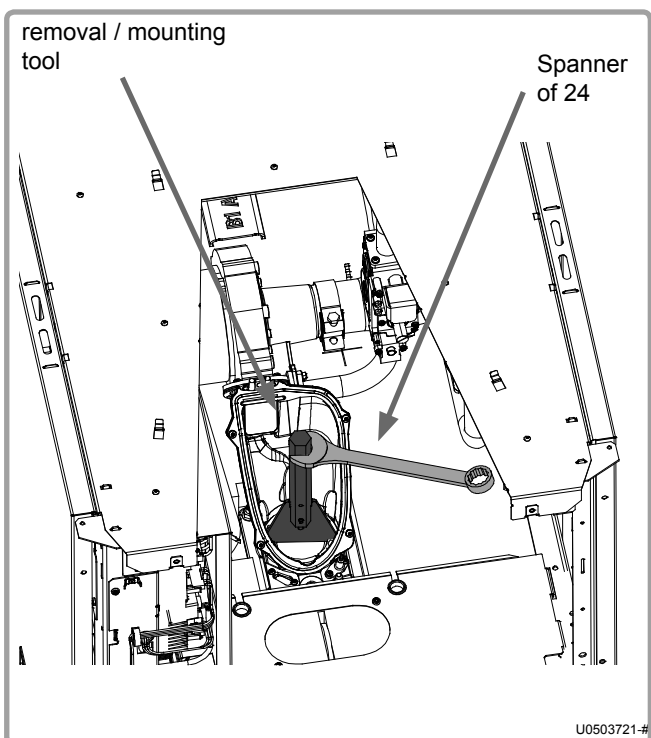

figure 50 - Release the burner tube

- Put the burner tube's removal / mounting tool in position (the tool is located under the gas line to the right of the sleeve cover).
- Position the tool in the slots of the tightening flange and compress on it (by pressing down) .

- Rotate the tool anticlockwise to unlock the ramp.

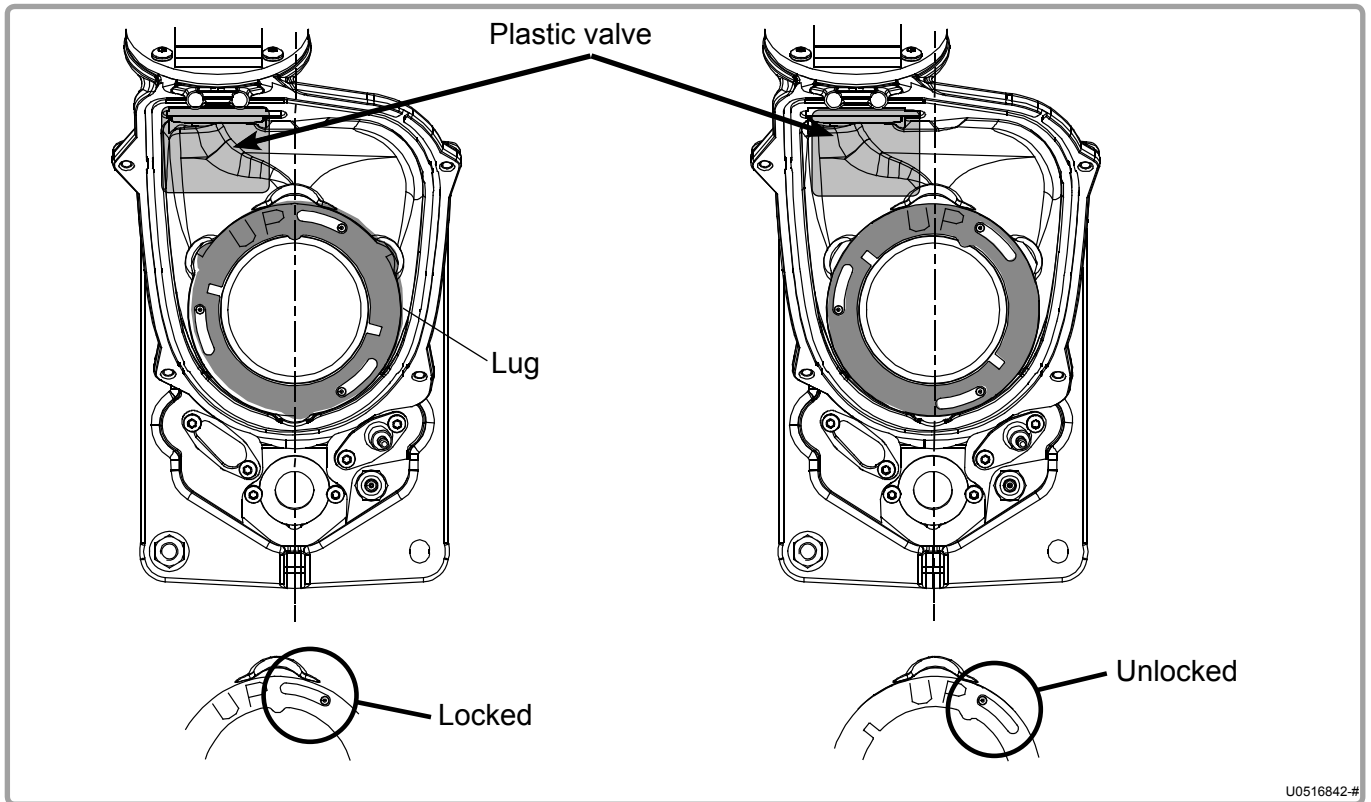

figure 51 - Positions of the fastening clamps

- Remove the clamp from the burner tube.
- Remove the burner tube.



WARNING: Remove the plastic valve on the spool piece before removing the burner tube. Do not forget to put it back when refitting.



WARNING: When removing the burner tube, be careful not to rub metal mesh against the spool piece.

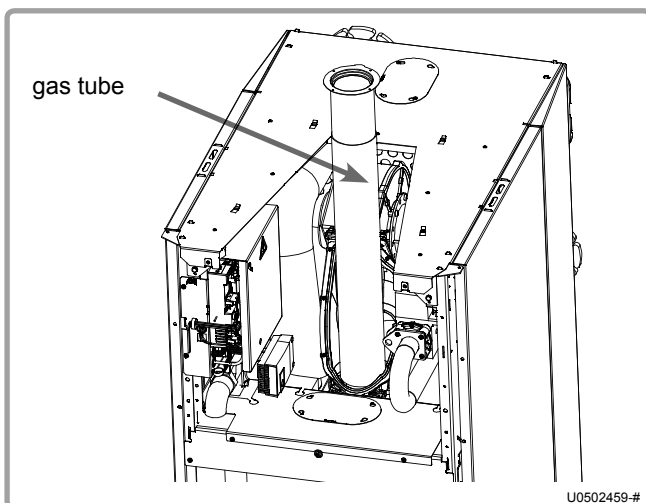

figure 52 - Cleaning the gas tube

Cleaning the burner tube:

- Suck out the entire surface in metal mesh using a vacuum cleaner.

**WARNING:**

**Keep a distance of 10 mm between the suction nozzle and the metal mesh. Any rubbing of the boiler tube may cause damage.
NEVER USE A METAL BRUSH.**

**WARNING:**

Replace the seal under the clamp on the burner tube.

Refitting:

- Put the burner tube into the spool piece (be careful not to rub the metal mesh on the spool piece). A directional pin enables the burner tube to be correctly positioned.
- Position the clamp (the word "UP" must be visible and the inner lug must be positioned on the rear axis of the boiler - see figure 47)
- Position the burner tube's removal / mounting tool in the slots in the clamp.
- Compress by pushing downwards and rotate the tool in a clockwise direction to lock the tube (see figure 47).

- Check the seal on the spool piece's cover and replace if necessary.
- Position the cover over the spool piece.
- Screw the cover onto the spool piece using the screws (tightening torque = 5 N.m).
- Refit the 2 electrode blocks.

**WARNING:**

Check the different seals after mounting. If using a foaming product, be careful of the ionisation electrode's electrical connection.

8. END-OF-LIFE CYCLE OF THE APPARATUS

Regulatory disposal and managed recycling of this product can prevent damage to the environment and health risks.

- a) For the disposal of the product and the component parts, the services of an accredited waste disposal company should be used.
- b) For more information on waste disposal/management, contact the Local Authority responsible for waste management or the point of sales where the product was purchased





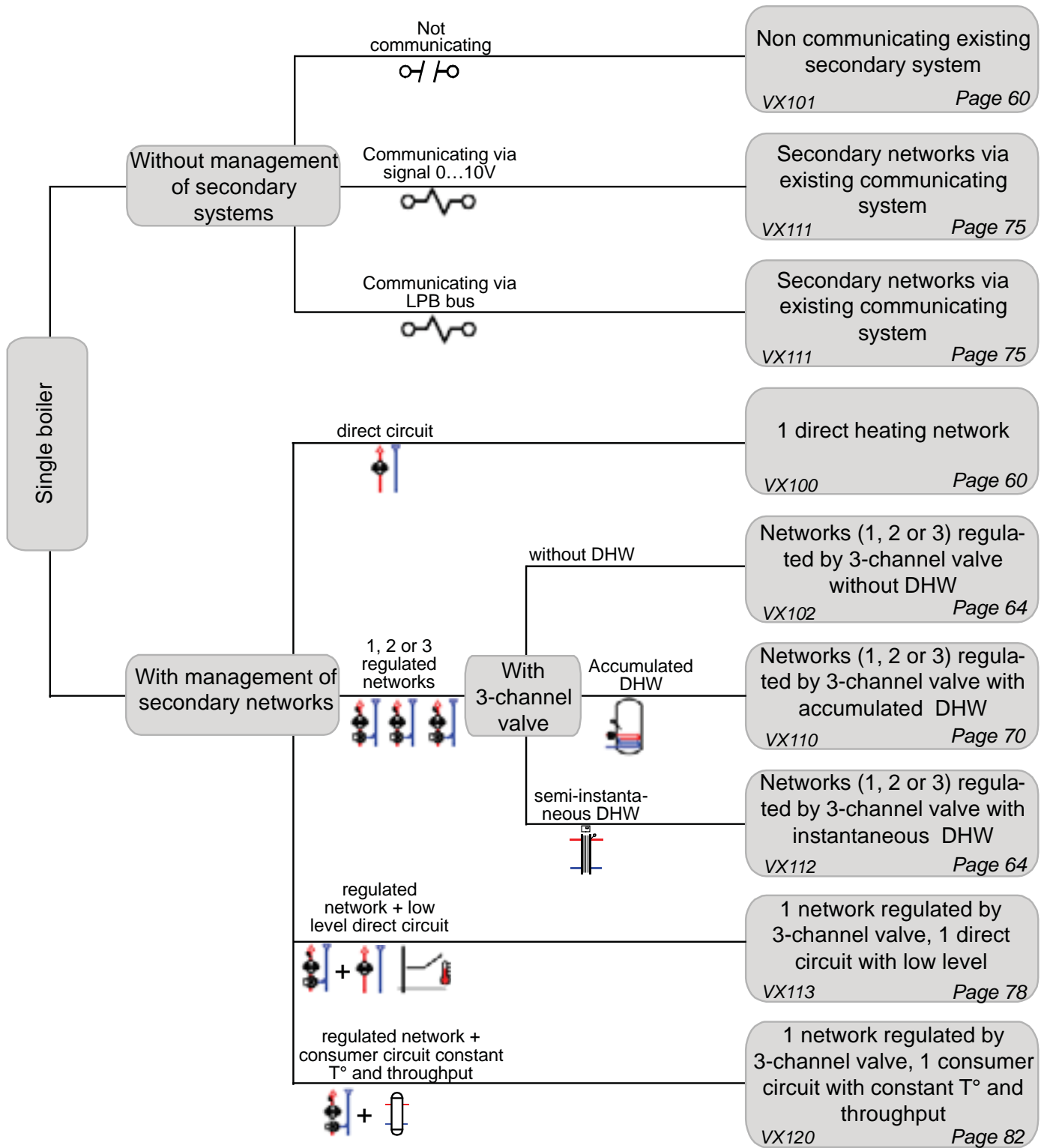

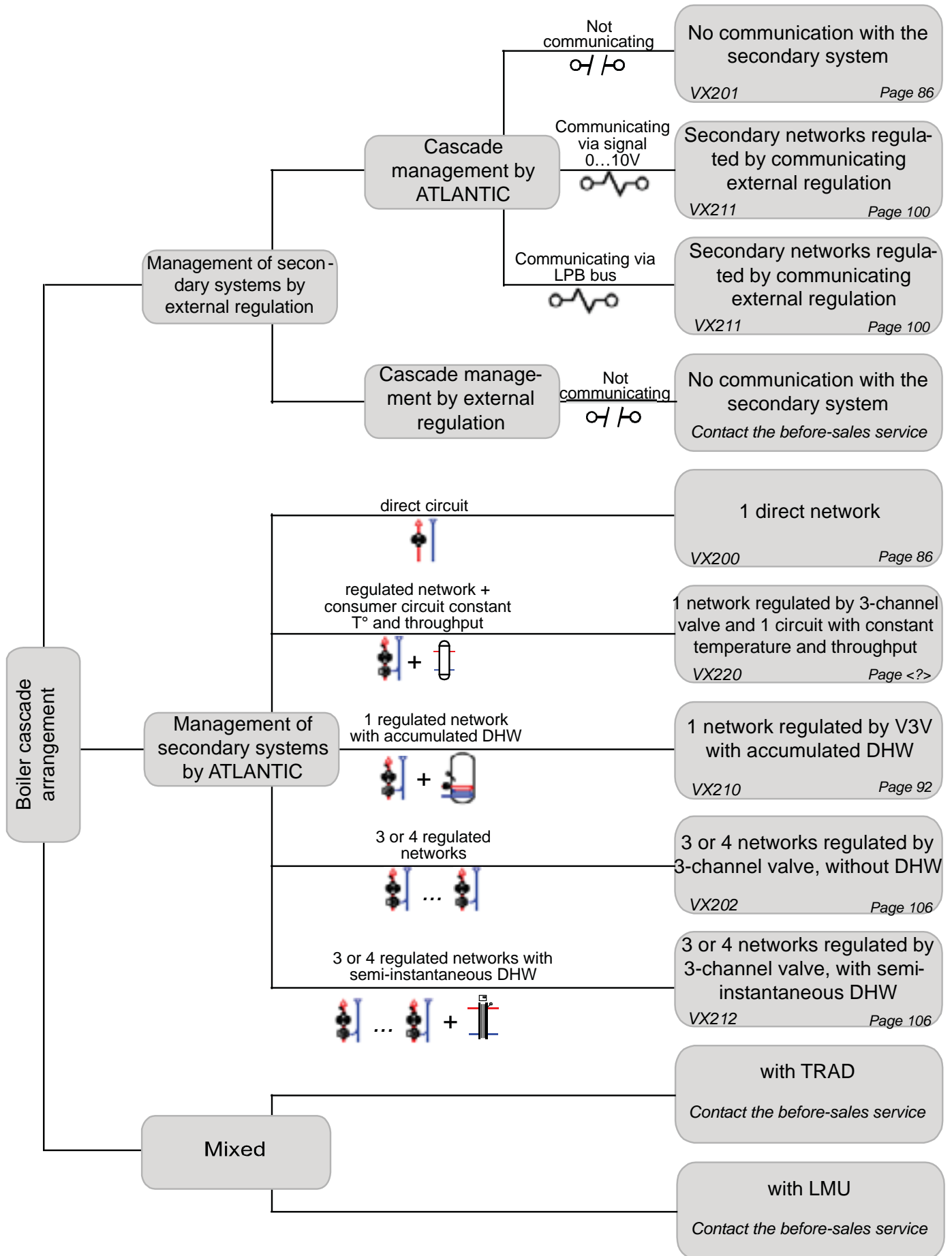
9. HYDRAULIC DIAGRAMS AND SETTINGS







9.1. Selection flow diagram





9.2. Symbols used in the diagrams

Symbol	Function
	Open isolating valve
	Motorised 2 channel valve
	Filter
	Safety unit
	Sediment well
	External sensor

Symbol	Function
	Balancing valve
	Motorised 3 channel valve
	Non-return valve
	Pump
	Drain valve
	Temperature sensor

9.3. List of diagrams



WARNING:

Operation at constant temperature with variable flow and immediate DHW production directly on heat plate exchanger without buffer tank forbidden.

SINGLE BOILER.....	60
1 direct heating network or existing non-communicative secondary system.....	60
VX100, VX101	
3 regulated networks with or without DHW production.....	64
VX102, VX112	
1 network regulated by a 3-channel valve, and DHW production	70
VX110	
Secondary networks with existing regulation communicating by LPB bus or 0...10V	75
VX111	
1 network regulated by a 3-channel valve, 1 direct circuit with 60°C low level	78
VX113	
1 network regulated by a three-channel valve, 1 circulation circuit with constant temperature and throughput	82
VX120	
BOILERS IN A CASCADE CONFIGURATION.....	86
1 direct network, no communication with the secondary network	86
VX200, VX201	
1 network regulated by a three-channel valve, DHW production or 1 direct circuit with constant temperature and throughput	92
VX210, VX220	
Secondary networks regulated by external regulated communicating by LPB bus or 0...10V	100
VX211	
3 or 4 networks regulated by a three-channel valve with or without DHW production	106
VX202, VX212	

SINGLE BOILER

1 direct heating network or existing non-communicative secondary system

Diagrams
VX100
VX101
 page 1 / 4

A. MAIN AND ALTERNATIVE HYDRAULIC DIAGRAMS

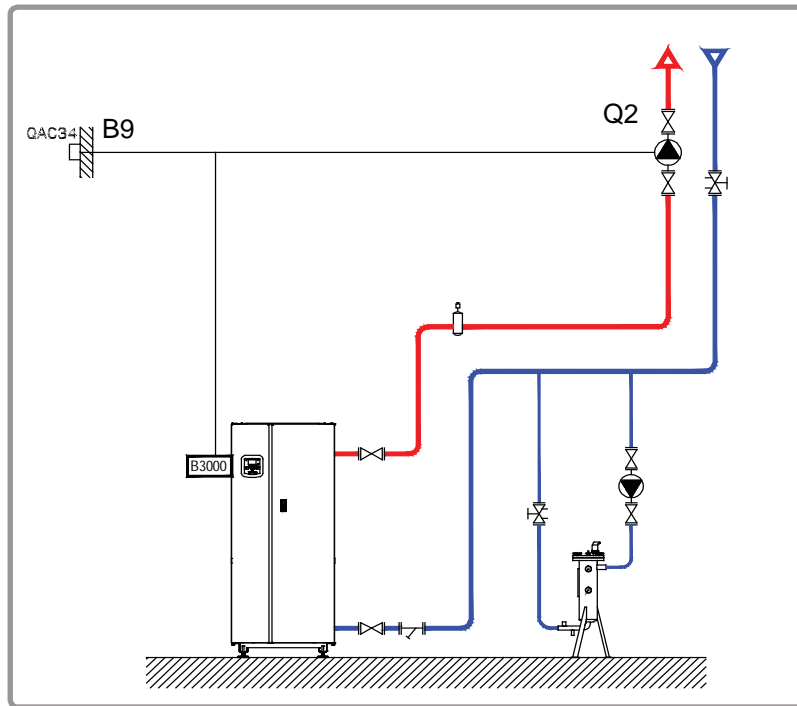

figure 53 - Diagram VX100

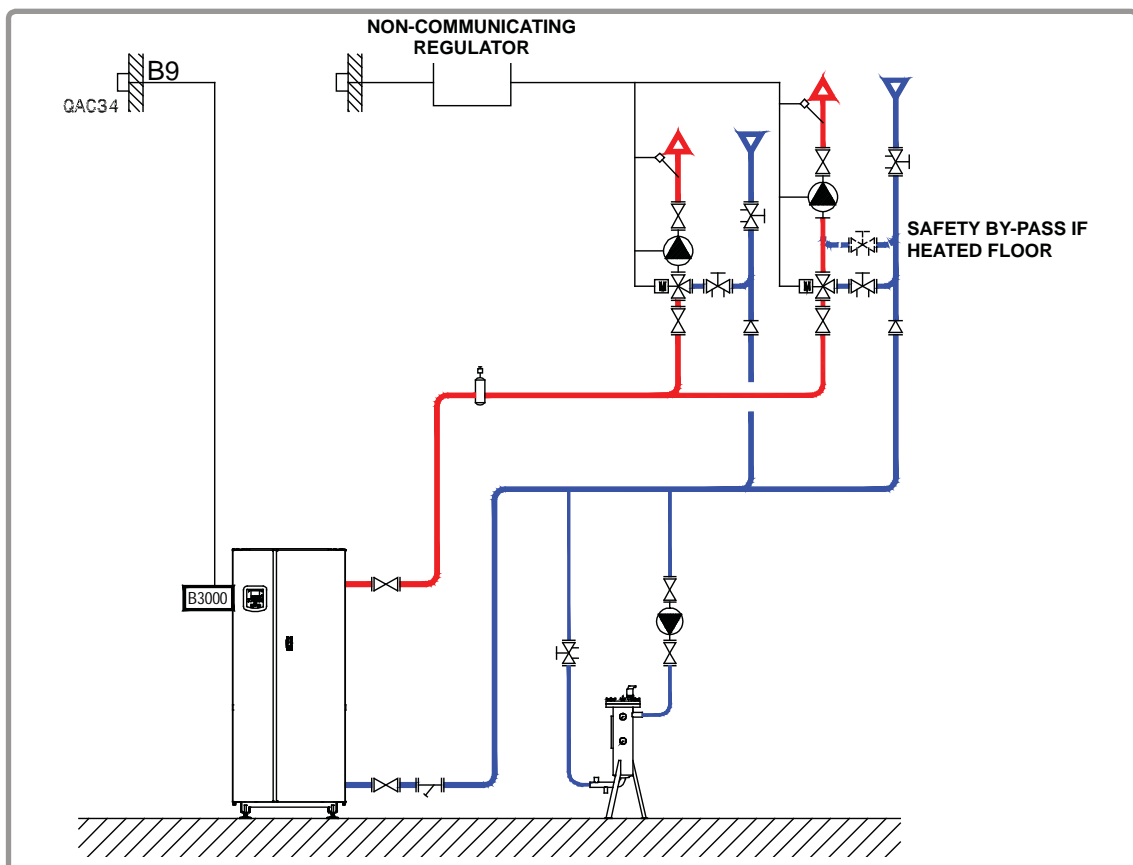
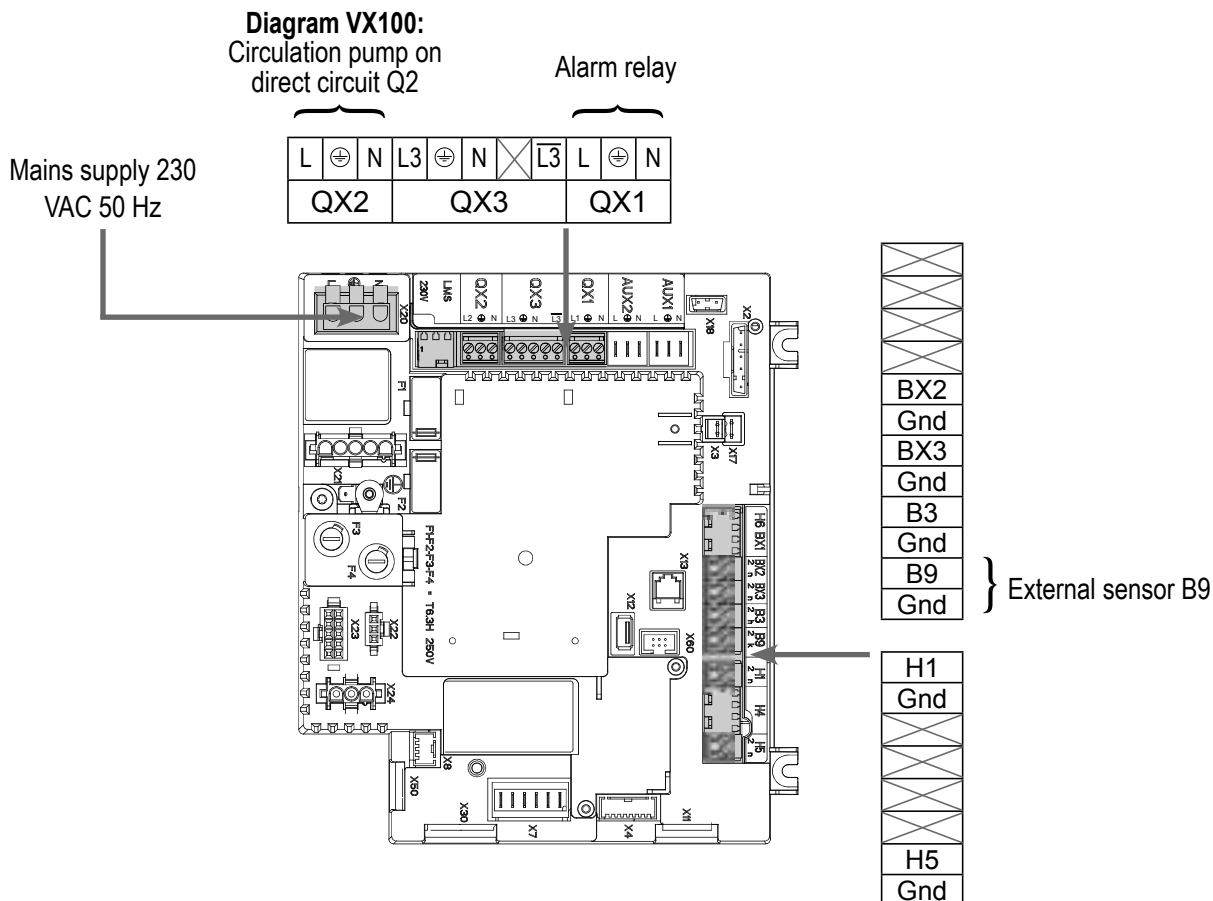

figure 54 - Diagram VX101 (alternative)

B. NECESSARY ADJUSTMENT ACCESSORY

	Quantity	Appliance reference	Order No.
External sensor kit	1	QAC 34	059260

C. CUSTOMER ELECTRICAL CONNECTION



D. SPECIFIC START-UP PROCEDURE

- ☞ Fit the accessories and make their electrical connections.
- ☞ Start up the boiler alone.
- ☞ Make the following settings:

- **Time and date** menu

- Set the time

Line No.	Value
Time / minute (1)	HH.MM
Day / month (2)	DD.MM
Year (3)	YYYY

- Set the date

- Set the year

- **Configuration** menu

- Start up the heating circuit 1

Heating circuit 1 (5710)	On
--------------------------	----

- Define the pump outlet Q2 (**diagram VX100**)

QX2 relay outlet (5891)	Pump CC1 Q2
-------------------------	-------------

	<i>Line No.</i>	<i>Value</i>
<ul style="list-style-type: none"> • Heating circuit 1 menu <ul style="list-style-type: none"> Set the comfort setting Comfort setting temperature (710) Set the curve slope Heating curve slope (720) 		--- ---
<ul style="list-style-type: none"> • Switch the heating mode to permanent comfort 		

E. ELECTRICAL AND HYDRAULIC VALIDATION

<ul style="list-style-type: none"> • Input/output test menu <ul style="list-style-type: none"> Check the outputs <ul style="list-style-type: none"> Alarm relay Relay test (7700) Heating circuit No. 1 pump (diagram VX100) Relay test (7700) Reset outputs Relay test (7700) 		Relay output QX1 Relay output QX2 No test
<ul style="list-style-type: none"> Check sensor values <ul style="list-style-type: none"> External sensor B9 External T° B9 (7730) 		in °C
<ul style="list-style-type: none"> • Configuration menu <ul style="list-style-type: none"> Check the hydraulic diagram <ul style="list-style-type: none"> Generator 1 check (6212) 14 Generator 2 check (6213) 0 Information on DHW (6215) 0 Information on heating circuits 3, 2 and 1 (6217) 1 (for VX101) 2 (for VX100) 		

F. OPTIMISATION OF SETTINGS

<ul style="list-style-type: none"> • Heating circuit 1 menu <ul style="list-style-type: none"> Set the reduced setting Reduced temperature setting (712) 		---
<ul style="list-style-type: none"> • CC1 time programme menu <ul style="list-style-type: none"> Preselection Preselection (500) Adjust the time programme On / Off phases (501...506) 		--- ---
<ul style="list-style-type: none"> • Circuit CC1 holiday menu <ul style="list-style-type: none"> Preselection Preselection (641) Adjust the time programme On / Off phases (642-643) 		--- ---
<ul style="list-style-type: none"> • Switch the heating mode to automatic 		AUTO

Maintenance optimisation:

It is possible to generate a maintenance message without harming the boiler. This maintenance message may appear when the 3 following meters have elapsed:

- Time since last maintenance (or commissioning): set parameter 7044 to 12 months
- Operating hours of the burner (parameter 7040)
- Number of start-ups (parameter 7042)

The last 2 parameters depend on the boiler room's hydraulic installation. It is recommended to use at least parameter 7044 for yearly maintenance.

SINGLE BOILER

3 regulated networks with or without DHW production

Diagrams

VX102

VX112

page 1 / 6

A. MAIN AND ALTERNATIVE HYDRAULIC DIAGRAMS

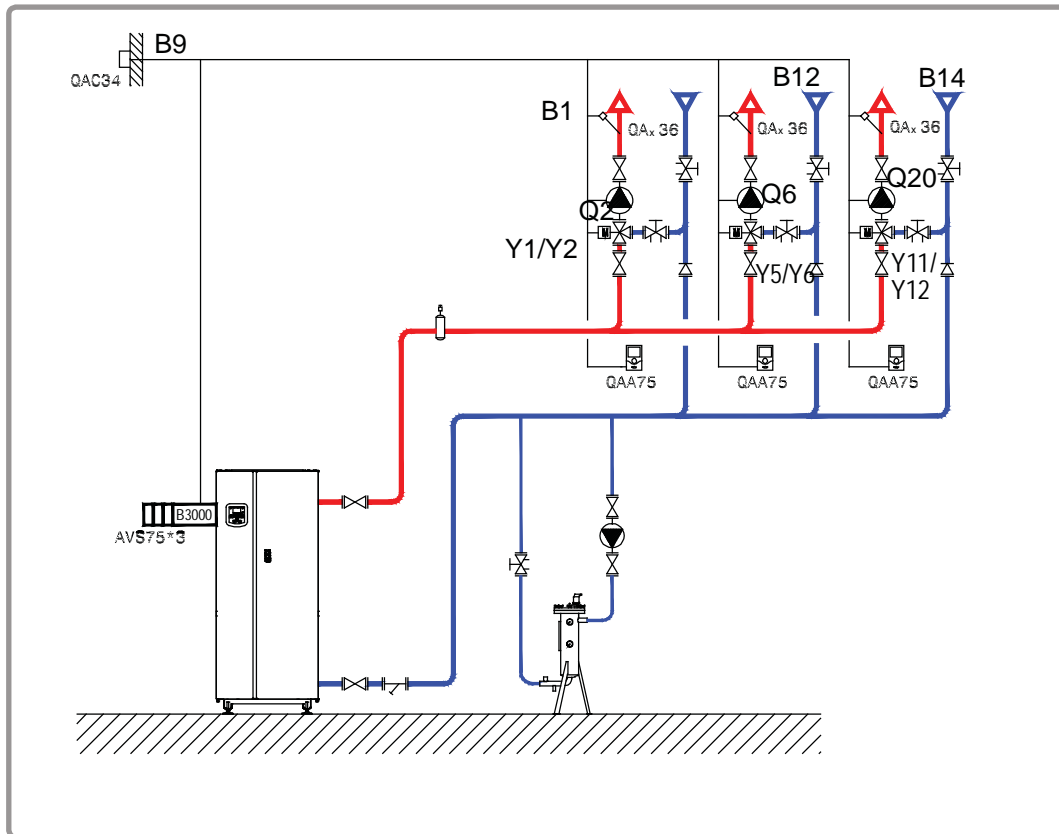

figure 55 - Diagram VX102

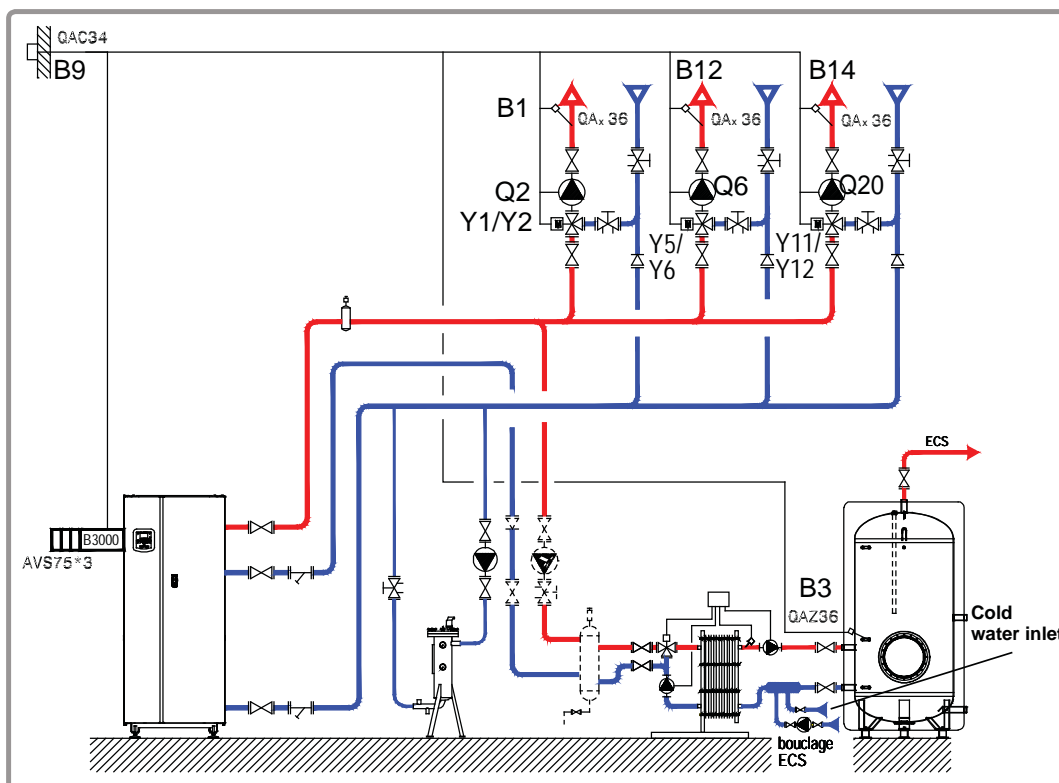
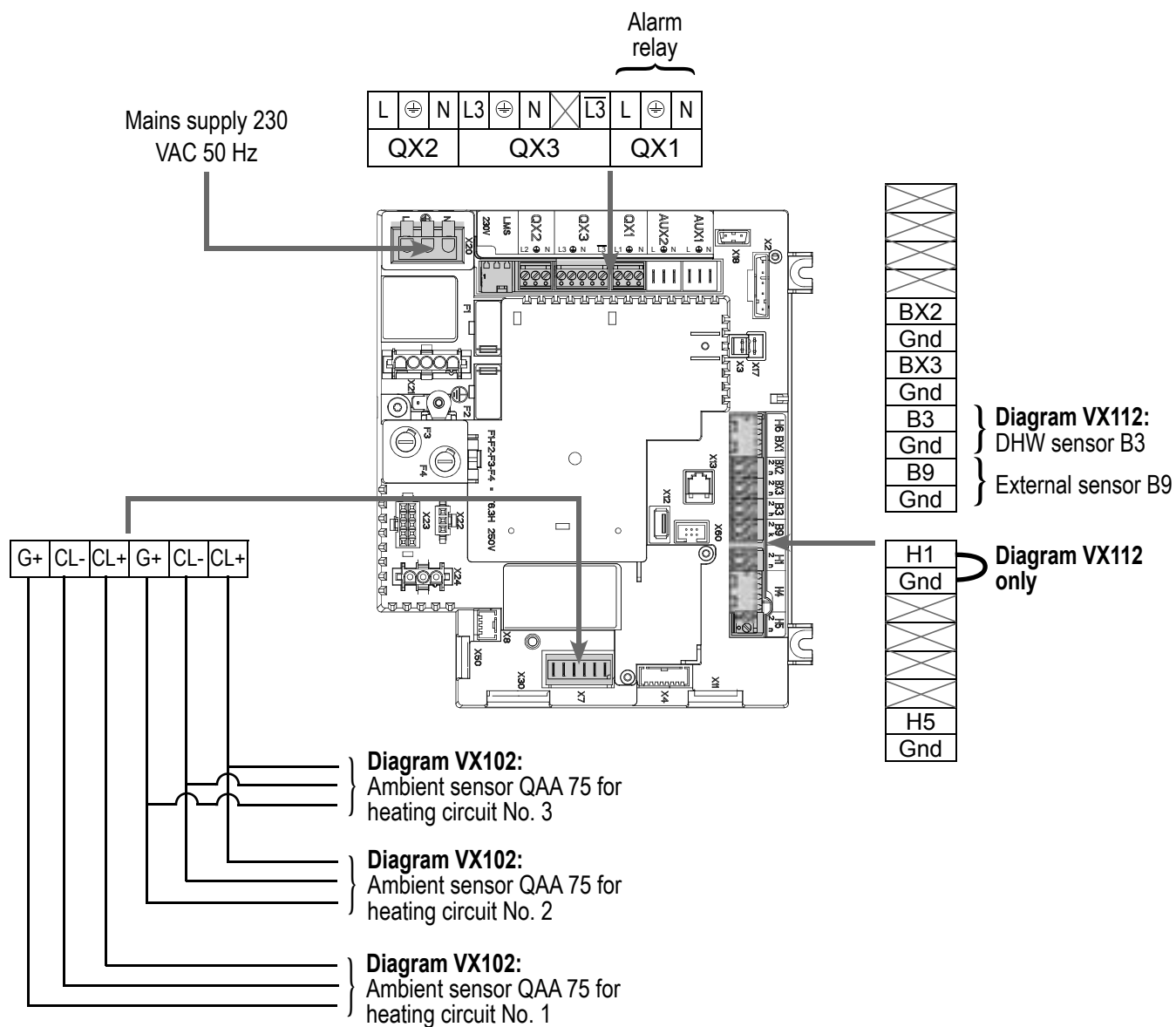

figure 56 - Diagram VX112 (alternative)

B. NECESSARY ADJUSTMENT ACCESSORIES

	Quantity	Appliance reference	Order No.
Extension module kit (delivered with a QAD 36 network sensor)	3	AVS 75	059751
External sensor kit	1	QAC 34	059260
Ambient sensor kit (diagram VX102)	3	QAA 75	040954
DHW sensor kit (diagram VX112)	1	QAZ 36	059261

C. CUSTOMER ELECTRICAL CONNECTION



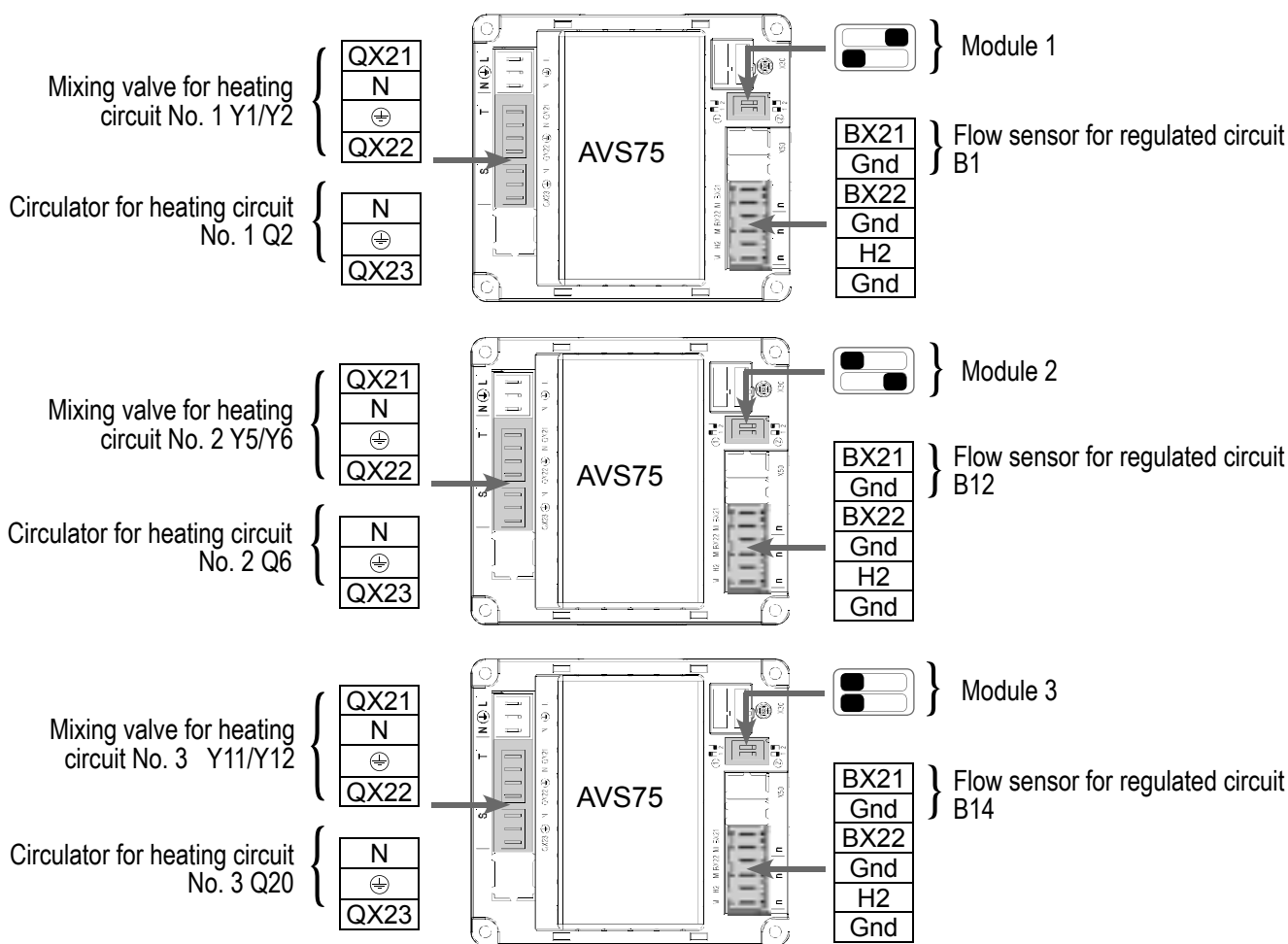

D. SPECIFIC START-UP PROCEDURE



☞ Fit the accessories and make their electrical connections.

⚠ WARNING: Ensure the switches on the extension modules AVS75 are properly configured.

☞ Start up the boiler alone.

☞ Make the following settings:

	Line No.	Value
• Time and date menu		
Set the time	Time / minute (1)	HH.MM
Set the date	Day / month (2)	DD.MM
Set the year	Year (3)	YYYY
• Configuration menu		
Start up the heating circuit 1	Heating circuit 1 (5710)	On
Start up the heating circuit 2	Heating circuit 2 (5715)	On
Start up the heating circuit 3	Heating circuit 3 (5721)	On

	Line No.	Value
Diagram VX112 only:		
Define a low level	Input function H1 (5950)	Circulation circuit demand 1
Install a shunt on H1 OR reverse the direction of contact	Type of contact (5951)	Rest contact
For the DHW to be effective, it is necessary to define a trigger, even if it is not connected.	Output via relay QX2 (5891)	Pump/valve ECS Q3
Configure the extension modules	Function of extension module 1 (6020)	Heating circuit 1
	Function of extension module 2 (6021)	Heating circuit 2
	Function of extension module 3 (6022)	Heating circuit 3
• Heating circuit 1 / 2 / 3 menu		
For each circuit		
Set the comfort setting	Temperature of comfort setting (710/1010/1310)	---
Set the curve slope	Slope of the heating curve(720/1020/1320)	---
• Switch the heating mode to permanent comfort		
Diagram VX112 only:		
• Circulation circuit 1 menu		
Set the starting value to use in the event of a demand from the circulation circuit	Starting value in case of circuit demand (1859)	60°C (depends on Rubis setting)
• Domestic hot water menu		
Set the comfort setting	Comfort setpoint (1610)	55 °C
Set the DHW release mode	DHW release (1620)	24/7
• Activate DHW mode		

E. ELECTRICAL AND HYDRAULIC VALIDATION

	<i>Line No.</i>	<i>Value</i>
• <i>Input/output test</i> menu		
Check the outputs		
Alarm relay	Relay test (7700)	Relay output QX1
All relays of extension modules	Relay test (7700)	Relay output QX
Reset outputs	Relay test (7700)	No test
Check sensor values		
External sensor B9	External T° B9 (7730)	in °C
DHW sensor B3	DHW temperature B3/B38 (7750)	in °C
Flow sensor B1	Temperature sensor BX21 module 1 (7830)	in °C
Flow sensor B12	Temperature sensor BX21 module 2 (7832)	in °C
Flow sensor B14	Temperature sensor BX21 module 3 (7834)	in °C
Diagram VX112 only:		
Check the condition of contact H1	Condition of contact H1 (7841)	Closed if the shunt is in place
• <i>Configuration</i> menu		
Check the hydraulic diagram		
	Generator 1 check (6212)	14
	Generator 2 check (6213)	0
	Information on DHW (6215)	0 (<i>diagram VX102</i>) 4 (<i>diagram VX112</i>)
	Information on heating circuits 3, 2 and 1 (6217)	30303

F. OPTIMISATION OF SETTINGS

Optimisation of the heating circuits:

	<i>Line No.</i>	<i>Value</i>
• <i>Heating circuit 1 / 2 / 3</i> menu		
Set the reduced setting	Reduced temperature setting (712/1012/1312)	---
• <i>Time programme CC1 / CC2 / CC3</i> menu		
Preselection	Preselection (500/520/540)	---
Adjust the time programme	On / Off phases (501...506) (521...526) (541...546)	---

	Line No.	Value
<ul style="list-style-type: none"> • Holiday circuit CC1 / CC2 / CC3 menu <ul style="list-style-type: none"> Preselection Adjust the time programme 	Preselection (641/651/661) On / Off phases (642-643) (652-653) (662-663)	--- ---
<ul style="list-style-type: none"> • Switch the heating mode to automatic 		AUTO

Optimisation of DHW:

	Line No.	Value
<ul style="list-style-type: none"> • DHW storage tank menu <ul style="list-style-type: none"> Adjust the boost 	Starting value of boost temperature (5020)	16 °C

Maintenance optimisation:

It is possible to generate a maintenance message without harming the boiler. This maintenance message may appear when the 3 following meters have elapsed:

- Time since last maintenance (or commissioning): set parameter 7044 to 12 months
- Operating hours of the burner (parameter 7040)
- Number of start-ups (parameter 7042)

The last 2 parameters depend on the boiler room's hydraulic installation. It is recommended to use at least parameter 7044 for yearly maintenance.

G. SETTING AMBIENT SENSORS

Connect each sensor to a heating circuit:

	Line No.	Value
<ul style="list-style-type: none"> • User interface menu of <u>each ambient sensor</u> <ul style="list-style-type: none"> Configure the ambient sensor with a heating circuit 	Use (40)	Ambient appliance 1 or 2 or 3

Each ambient sensor allows its heating circuit to be configured. Ambient sensors 1, 2 and 3 respectively set parameters 712 (heating circuit 1), 1012 (heating circuit 2) and 1312 (heating circuit 3).

<h2 style="margin: 0;">SINGLE BOILER</h2> <p style="margin: 0;"><i>1 network regulated by a 3-channel valve, and DHW production</i></p>	<p>Diagram VX110 page 1 / 5</p>
---	--

A. HYDRAULIC DIAGRAM

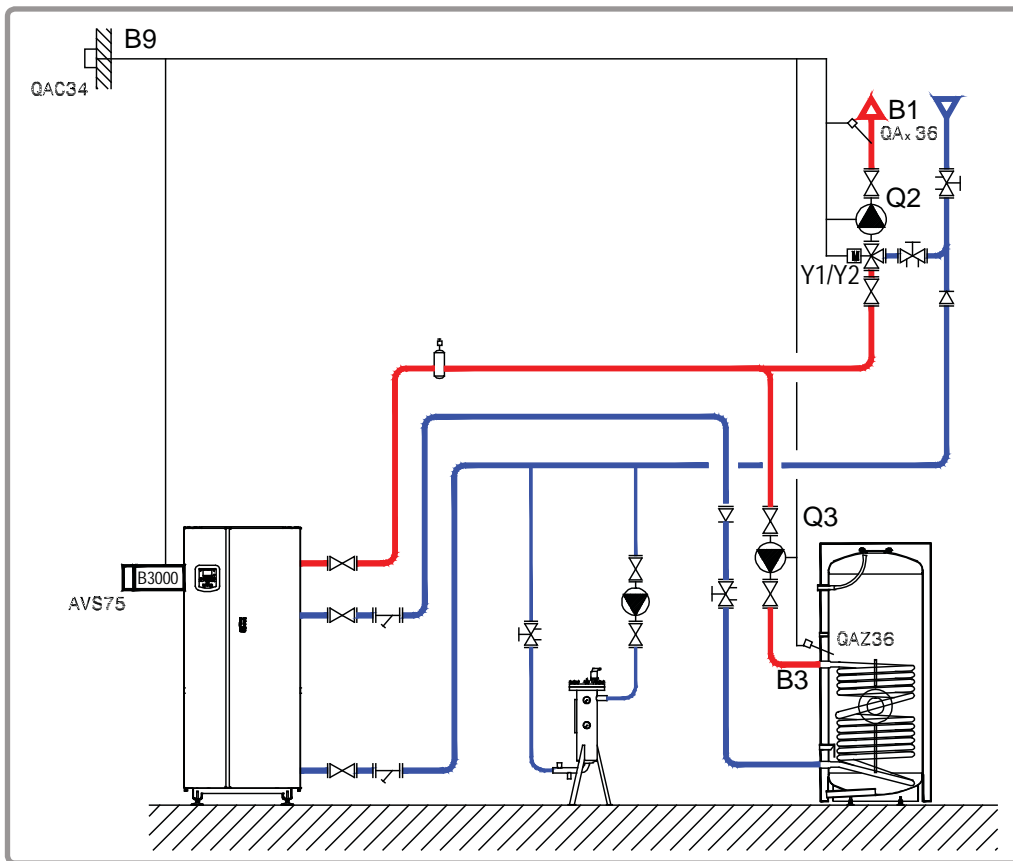

figure 57 - VX110 diagram

B. NECESSARY ADJUSTMENT ACCESSORIES

	Quantity	Appliance reference	Order No.
Extension module kit (delivered with a QAD 36 network sensor)	1	AVS 75	059751
DHW sensor kit	1	QAZ 36	059261
External sensor kit	1	QAC 34	059260

Diagram VX110 page 2 / 5

C. CUSTOMER ELECTRICAL CONNECTION

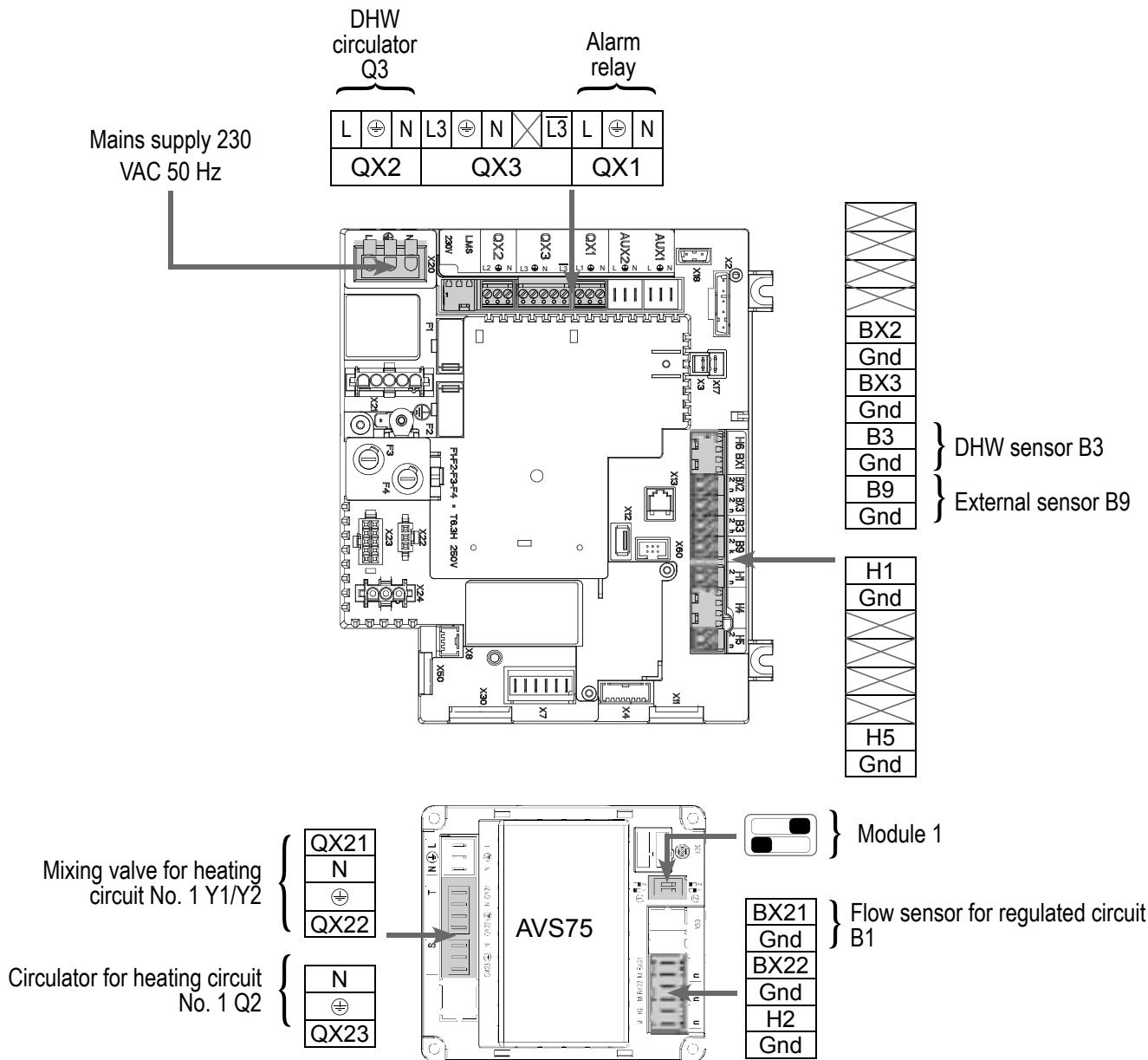

D. SPECIFIC START-UP PROCEDURE

Fit the accessories and make their electrical connections.





WARNING:

Ensure the switches on the extension modules AVS75 are properly configured.

- Start up the boiler alone.
- Make the following settings.

Diagram VX110

	Line No.	Value
• Time and date menu		
Set the time	Time / minute (1)	HH.MM
Set the date	Day / month (2)	DD.MM
Set the year	Year (3)	YYYY
• Configuration menu		
Start up the heating circuit 1	Heating circuit 1 (5710)	On
Configure the DHW pump	Output via relay QX2 (5891)	Pump/valve ECS Q3
Configure extension module 1	Function of extension module 1 (6020)	Heating circuit 1
• Heating circuit 1 menu		
Set the comfort setting	Comfort setting temperature (710)	---
Set the curve slope	Heating curve slope (720)	---
• Switch the heating mode to permanent comfort		
• Domestic hot water menu		
Set the comfort setting	Comfort setpoint (1610)	---
• Activate DHW mode		

E. ELECTRICAL AND HYDRAULIC VALIDATION

	Line No.	Value
• Input/output test menu		
Check the outputs		
Alarm relay	Relay test (7700)	Relay output QX1
DHW pump Q3	Relay test (7700)	Relay output QX2
Opening V3V CC	Relay test (7700)	Relay output QX21 module 1
Closing V3V CC	Relay test (7700)	Relay output QX22 module 1
CC pump	Relay test (7700)	Relay output QX23 module 1

Diagram VX110

	Line No.	Value
Reset outputs...module...	Relay test (7700)	No test
Check sensor values		
External sensor B9	External T° B9 (7730)	in °C
DHW sensor B3	DHW temperature B3/B38 (7750)	in °C
Flow sensor B1	Temperature sensor BX21 module 1 (7830)	in °C
• Configuration menu		
Check the hydraulic diagram	Generator 1 check (6212)	14
	Generator 2 check (6213)	0
	Information on DHW (6215)	4
	Information on heating circuits 3, 2 and 1 (6217)	3

F. OPTIMISATION OF SETTINGS

Optimisation of heating circuit:

	Line No.	Value
• Heating circuit 1 menu		
Set the reduced setting	Reduced temperature setting (712)	---
• CC1 time programme menu		
Preselection	Preselection (500)	---
Adjust the time programme	On / Off phases (501...506)	---
• Circuit CC1 holiday menu		
Preselection	Preselection (641)	---
Adjust the time programme	On / Off phases (642-643)	---
• Switch the heating mode to automatic		AUTO

Optimisation of DHW:

	Line No.	Value
• Domestic hot water menu		
Set the reduced setting	Reduced setting (1612)	---
Set the DHW release mode	DHW release (1620)	Time programme 4/ DHW

Diagram VX110

	<i>Line No.</i>	<i>Value</i>
• <i>Time programme 4 / ECS</i> menu		
Preselection	Preselection (560)	---
Adjust the time programme	On / Off phases (561...566)	---
• <i>DHW storage tank</i> menu		
Adjust the boost	Starting value of boost temperature (5020)	---
• <i>Domestic hot water</i> menu		
Configure an anti-legionella function	Anti-legionella function (1640)	---
	Periodic anti-legionella function (1641)	---
	Day week anti-legionella function (1642)	---
	Anti-legionella temperature setting (1645)	---
	Duration of anti-legionella function (1646)	---

Maintenance optimisation:

It is possible to generate a maintenance message without harming the boiler. This maintenance message may appear when the 3 following meters have elapsed:

- Time since last maintenance (or commissioning): set parameter 7044 to 12 months
- Operating hours of the burner (parameter 7040)
- Number of start-ups (parameter 7042)

The last 2 parameters depend on the boiler room's hydraulic installation. It is recommended to use at least parameter 7044 for yearly maintenance.

<p>SINGLE BOILER</p> <p><i>Secondary networks with existing regulation communicating by LPB bus or 0...10V</i></p>	<p>Diagram VX111</p> <p>page 1 / 3</p>
---	---

A. HYDRAULIC DIAGRAM

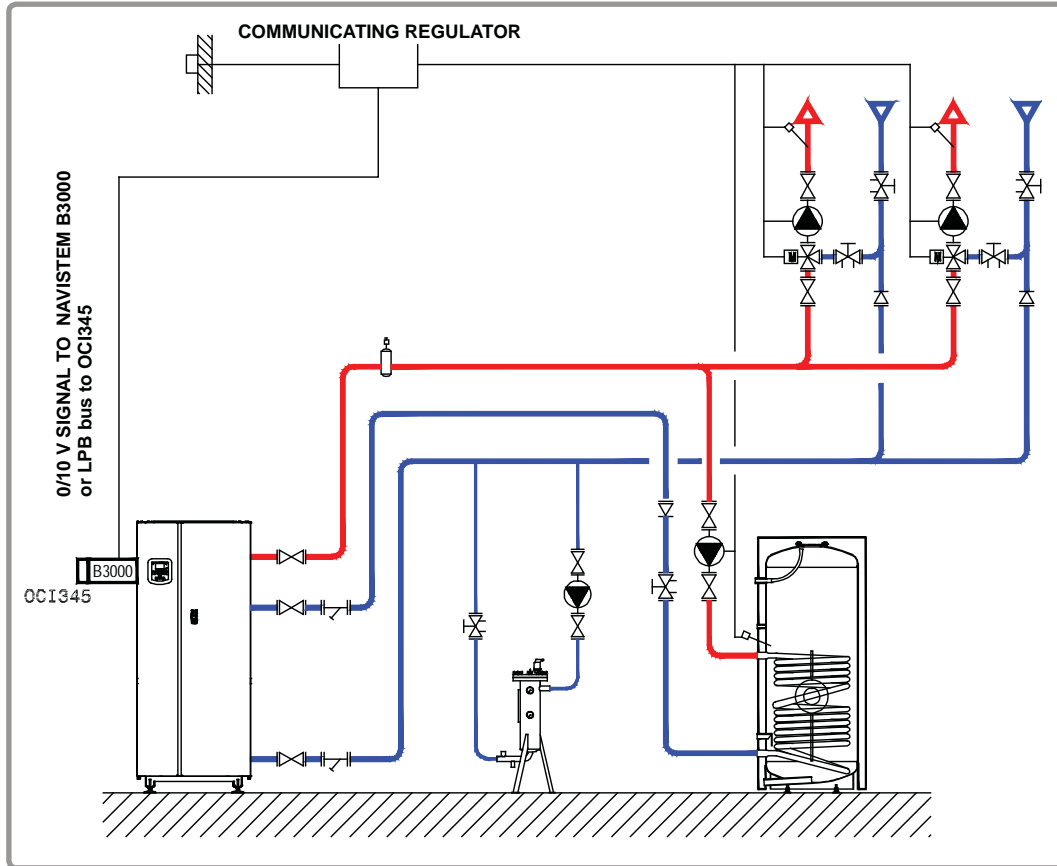

figure 58 - Diagram VX111

B. NECESSARY ADJUSTMENT ACCESSORY

	Quantity	Appliance reference	Order No.
Communication kit for LPB bus	1	OCI 345	059572

Diagram VX111

C. CUSTOMER ELECTRICAL CONNECTION

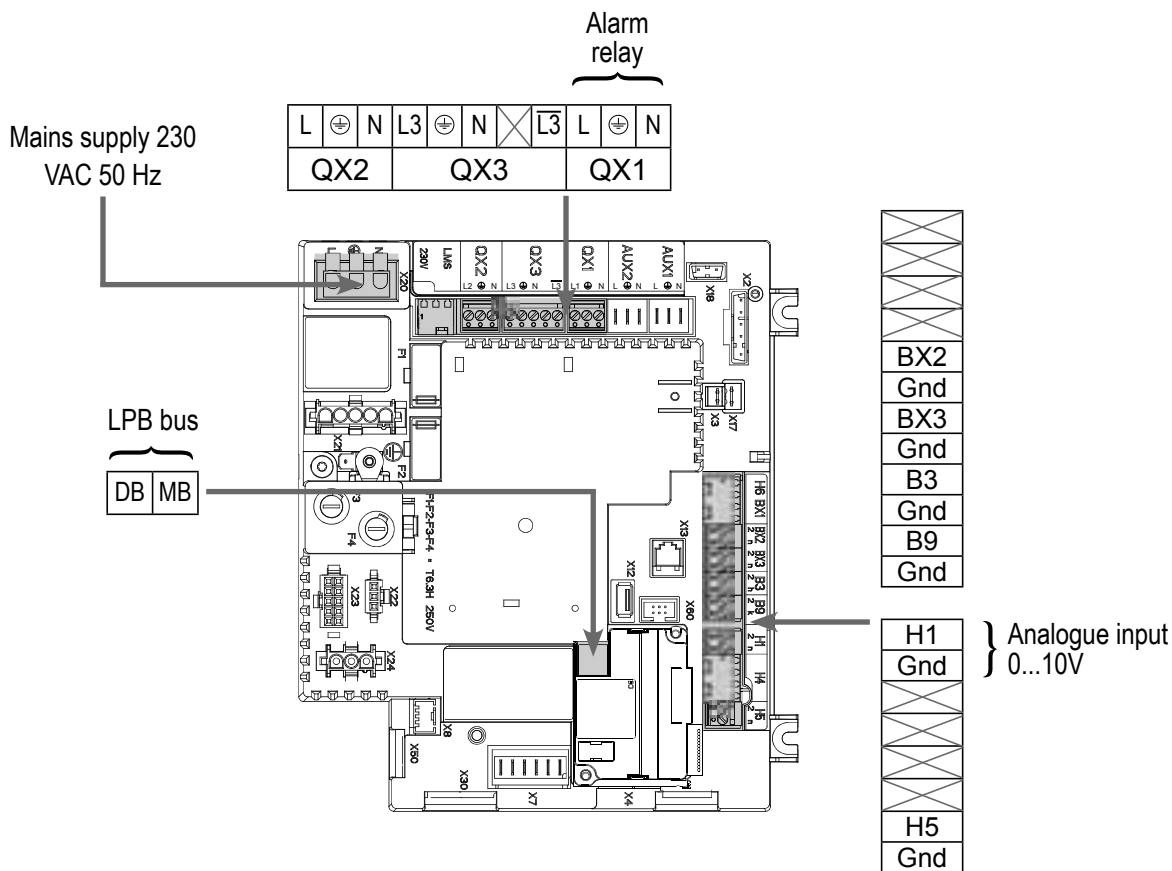

D. SPECIFIC START-UP PROCEDURE

- ☞ Fit the accessories and make their electrical connections.
- ☞ Start up the boiler alone.
- ☞ Make the following settings:

• **Time and date** menu

- Set the time
- Set the date
- Set the year

Line No.	Value
Time / minute (1)	HH.MM
Day / month (2)	DD.MM
Year (3)	YYYY

For a demand via input 0...10V

• **Configuration** menu

- Configure input H1

Input function H1 (5950)	Demand from circulation circuit
Voltage value 1 H1 (5953)	1 10V
Function value H1 (5954)	0.0
Voltage value 2 H1 (5955)	0
	10.0

	Line No.	Value
	Function value 2 H1 (5956)	1000 (for 10 V = 100 °C equivalence)
For a demand via LPB (LPB network menu)		
• LPB network menu		
Check that the boiler has been defined as the master generator	Appliance address (6600)	1
	Segment address (6601)	0
	Bus supply function (6604)	Automatic
	Clock function (6640)	Slave with adjustment

E. ELECTRICAL AND HYDRAULIC VALIDATION

For a demand via input 0...10V		
• Input/output test menu		
Voltage in H1	Voltage signal H1 (7840)	To validate with the voltage sent by the boiler room machine

For a demand via LPB

If the boiler room regulator is configured as the master clock, the boiler command table must recover the date and time.

In both cases

• Configuration menu		
Check the hydraulic diagram	Generator 1 check (6212)	14
	Generator 2 check (6213)	0
	Information on DHW (6215)	0
	Information on heating circuits 3, 2 and 1 (6217)	0

F. OPTIMISATION OF SETTINGS

Maintenance optimisation:

It is possible to generate a maintenance message without harming the boiler. This maintenance message may appear when the 3 following meters have elapsed:

- Time since last maintenance (or commissioning): set parameter 7044 to 12 months
- Operating hours of the burner (parameter 7040)
- Number of start-ups (parameter 7042)

The last 2 parameters depend on the boiler room's hydraulic installation. It is recommended to use at least parameter 7044 for yearly maintenance.

<p>SINGLE BOILER</p> <p><i>1 network regulated by a 3-channel valve, 1 direct circuit with 60°C low level</i></p>	<p>Diagram VX113</p> <p>page 1 / 4</p>
--	---

A. HYDRAULIC DIAGRAM

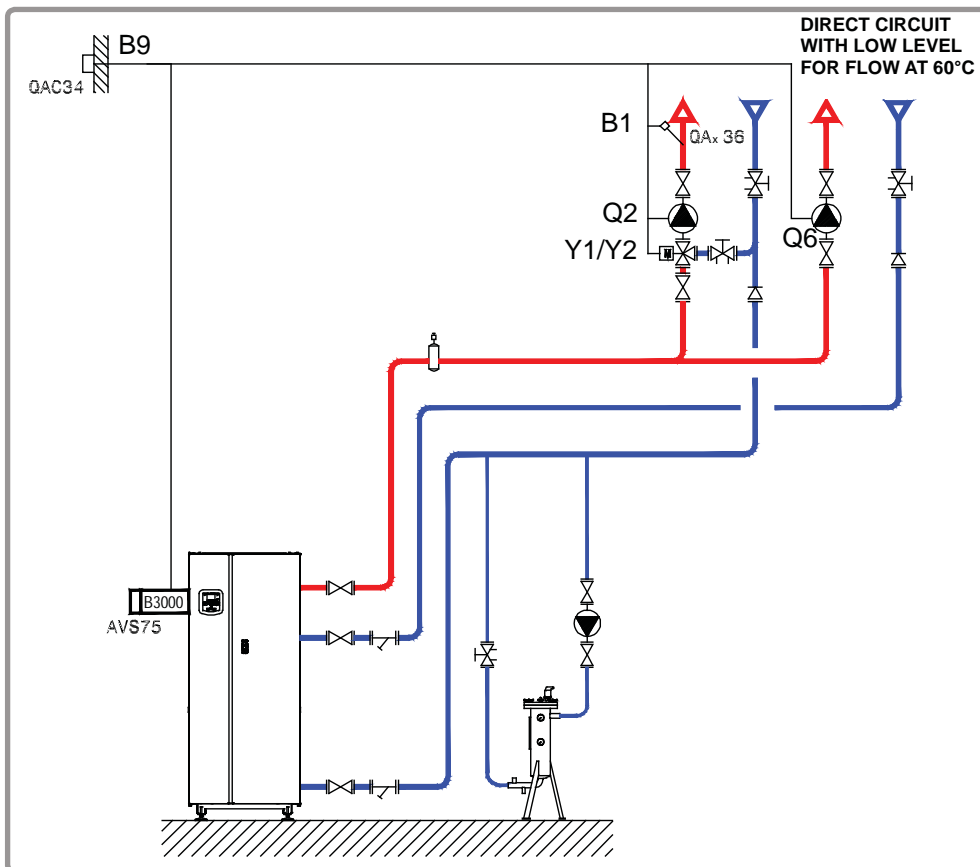

figure 59 - Diagram VX113

B. NECESSARY ADJUSTMENT ACCESSORIES

	Quantity	Appliance reference	Order No.
Extension module kit (delivered with a QAD 36 network sensor)	1	AVS 75	059751
External sensor kit	1	QAC 34	059260

Diagram VX113 page 2 / 4

C. CUSTOMER ELECTRICAL CONNECTION

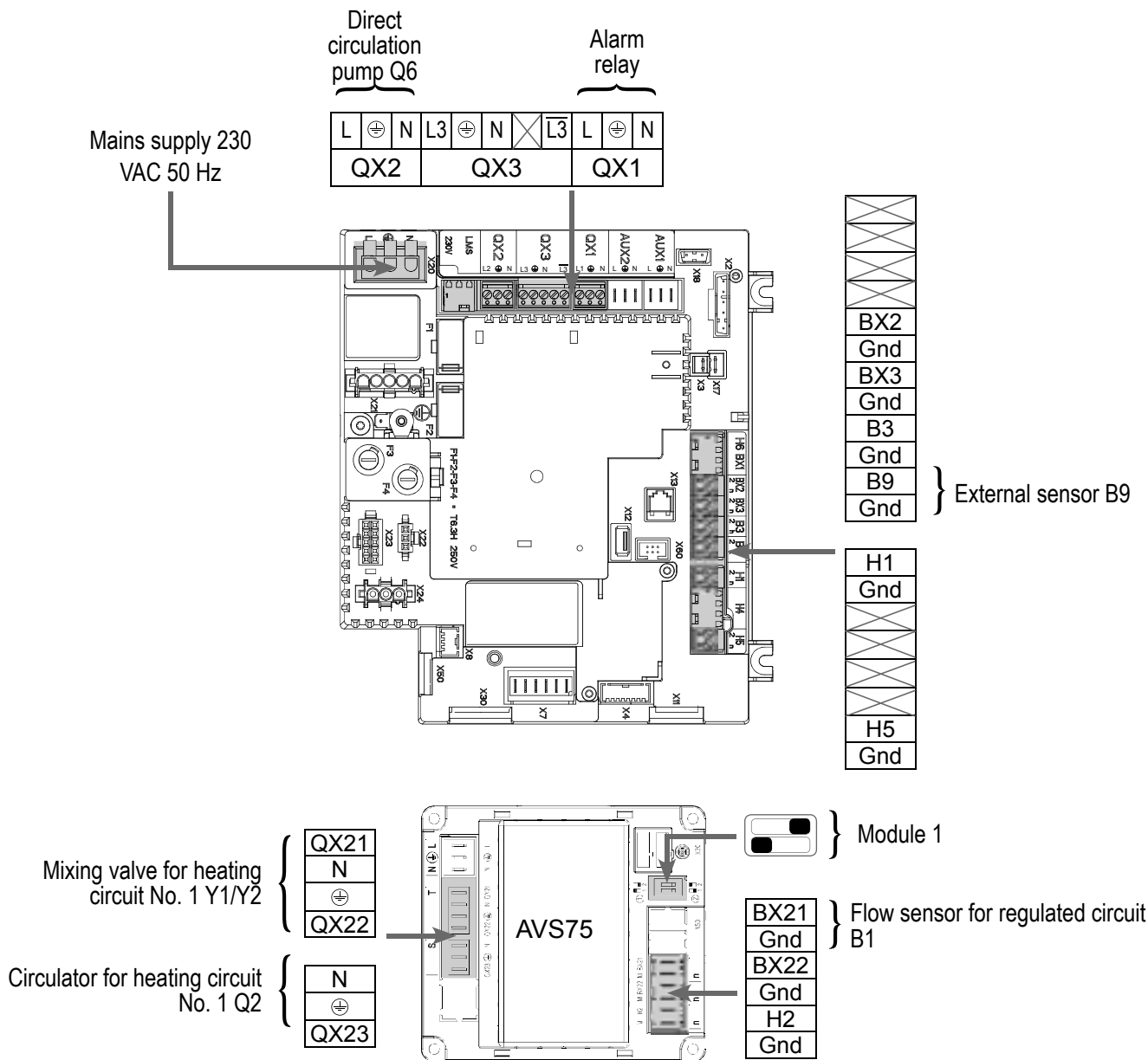

D. SPECIFIC START-UP PROCEDURE

Fit the accessories and make their electrical connections.

WARNING:

Ensure the switches on extension module AVS75 are correctly configured.

- Start up the boiler alone.
- Make the following settings.

Diagram VX113	page 3 / 4
----------------------	------------

	Line No.	Value
• Time and date menu		
Set the time	Time / minute (1)	HH.MM
Set the date	Day / month (2)	DD.MM
Set the year	Year (3)	YYYY
• Configuration menu		
Start up the heating circuit 1	Heating circuit 1 (5710)	On
Start up the heating circuit 2	Heating circuit 2 (5715)	On
Configure the pump CC2	Output via relay QX2 (5891)	Pump CC2 Q6
Configure extension module 1	Function of extension module 1 (6020)	Heating circuit 1
• Heating circuit 1 menu		
Set the comfort setting	Comfort setting temperature (710)	---
Set the curve slope	Heating curve slope (720)	---
• Heating circuit 2 menu		
Set the comfort setting	Comfort setting temperature (1010)	---
Set the curve slope	Heating curve slope (1020)	---
Set the minimum starting temperature	Minimum starting T° value (1040)	60°C (adjust depending on low level)

- Switch the heating mode to permanent comfort



E. ELECTRICAL AND HYDRAULIC VALIDATION

	Line No.	Value
• Input/output test menu		
Check the outputs		
Alarm relay	Relay test (7700)	Relay output QX1
CC2 pump	Relay test (7700)	Relay output QX2
Opening V3V CC	Relay test (7700)	Relay output QX21 module 1
Closing V3V CC	Relay test (7700)	Relay output QX22 module 1

Diagram VX113

	Line No.	Value
CC pump	Relay test (7700)	Relay output QX23 module 1
Reset outputs	Relay test (7700)	No test
Check sensor values		
External sensor B9	External T° B9 (7730)	in °C
Flow sensor B1	Temperature sensor BX21 module 1 (7830)	in °C
• Configuration menu		
Check the hydraulic diagram	Generator 1 check (6212)	14
	Generator 2 check (6213)	0
	Information on DHW (6215)	0
	Information on heating circuits 3, 2 and 1 (6217)	203

F. OPTIMISATION OF SETTINGS

	Line No.	Value
• Heating circuit 1 / 2 menu		
Set the reduced setting	Temperature of reduced setting (712/1012)	---
• Time programme CC1 / CC2 menu		
Preselection	Preselection (500/520)	---
Adjust the time programme	On / Off phases (501...506) (521...526)	---
• Holiday circuit CC1 / CC2 menu		
Preselection	Preselection (641/651)	---
Adjust the time programme	On / Off phases (642-643) (652-653)	---
• Switch the heating mode to automatic		AUTO

Maintenance optimisation:

It is possible to generate a maintenance message without harming the boiler. This maintenance message may appear when the 3 following meters have elapsed:

- Time since last maintenance (or commissioning): set parameter 7044 to 12 months
- Operating hours of the burner (parameter 7040)
- Number of start-ups (parameter 7042)

The last 2 parameters depend on the boiler room's hydraulic installation. It is recommended to use at least parameter 7044 for yearly maintenance.

<h2 style="margin: 0;">SINGLE BOILER</h2> <p style="margin: 0;"><i>1 network regulated by a three-channel valve, 1 circulation circuit with constant temperature and throughput</i></p>	<p>Diagram VX120 page 1 / 4</p>
---	--

A. HYDRAULIC DIAGRAM

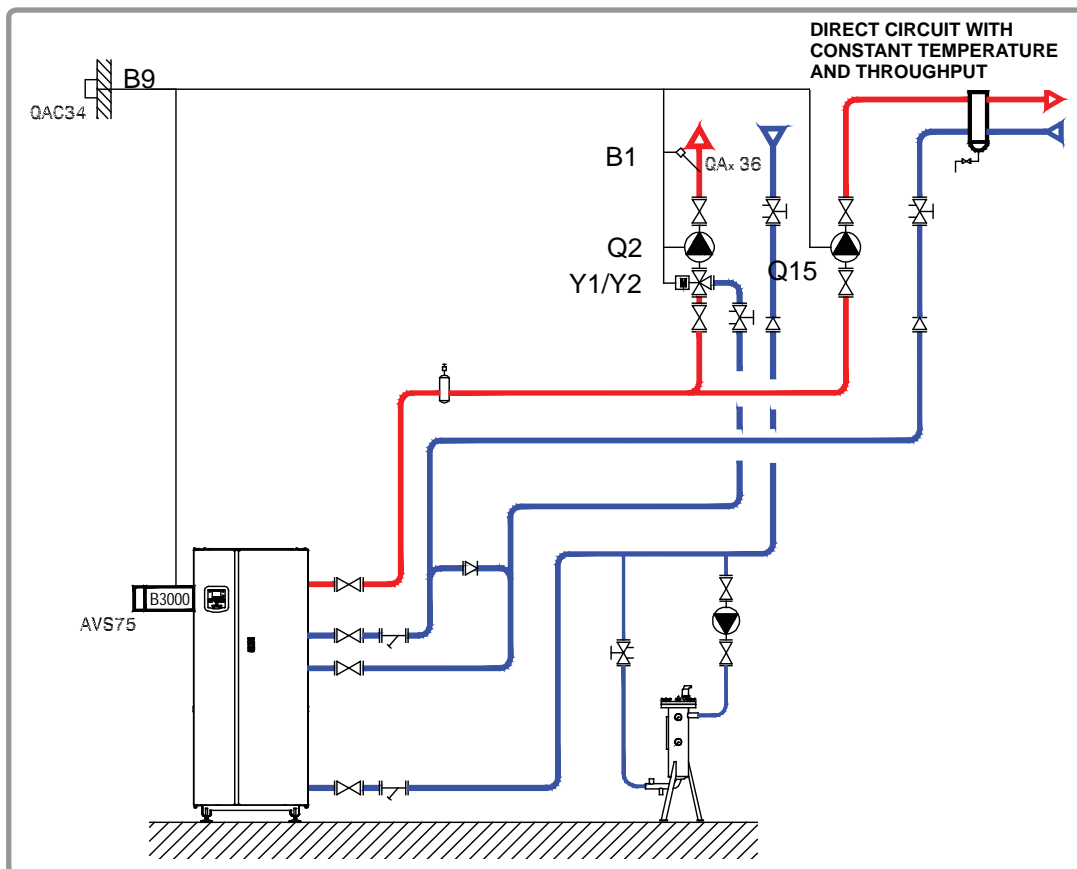

figure 60 - Diagram VX120

B. NECESSARY ADJUSTMENT ACCESSORIES

	Quantity	Appliance reference	Order No.
Extension module kit (delivered with a QAD 36 network sensor)	1	AVS 75	059751
External sensor kit	1	QAC 34	059260

Diagram VX120 page 2 / 4

C. CUSTOMER ELECTRICAL CONNECTION

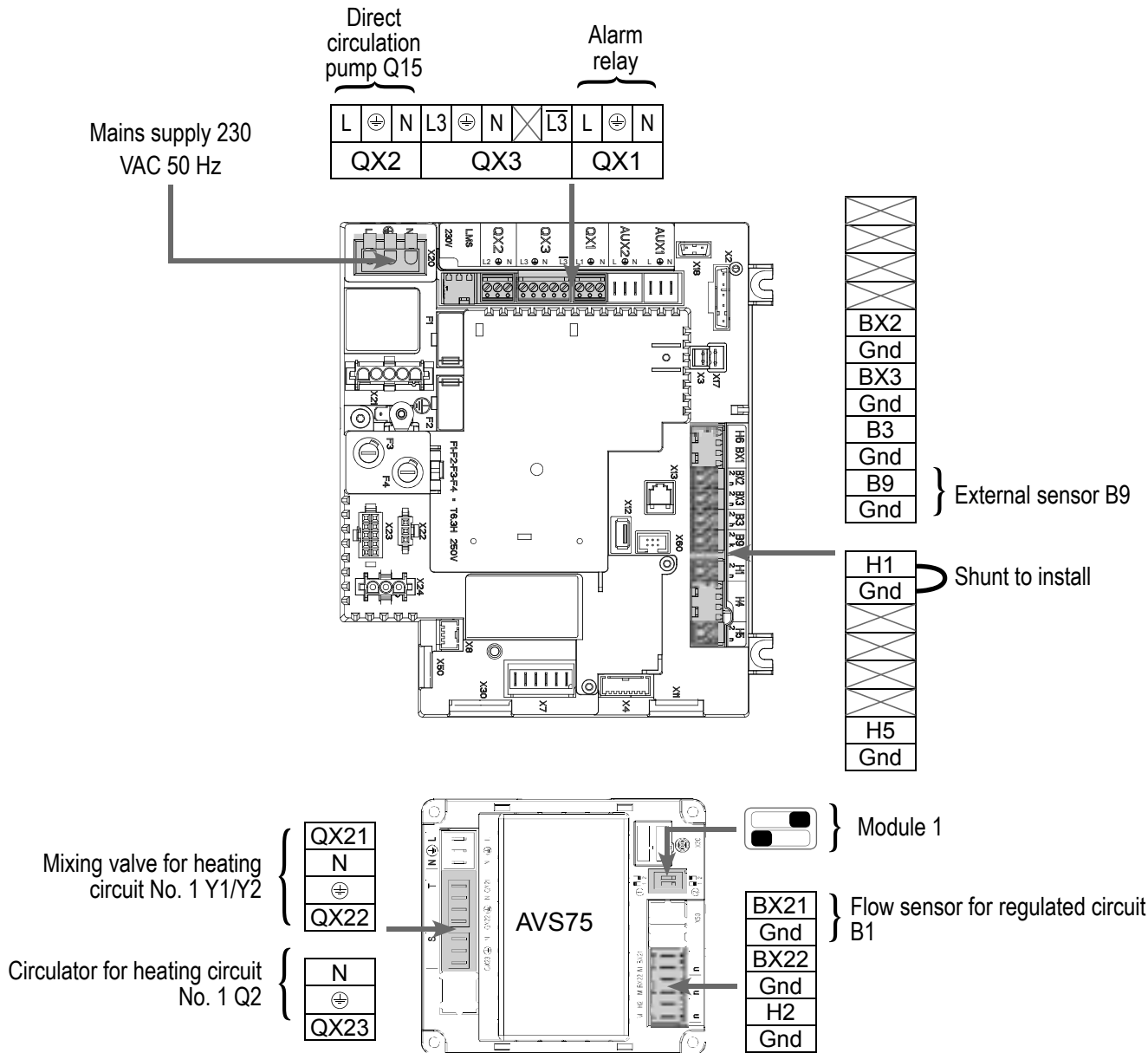

D. SPECIFIC START-UP PROCEDURE

Fit the accessories and make their electrical connections.

WARNING: **Ensure the switches on extension module AVS75 are correctly configured.**

- Start up the boiler alone.
- Make the following settings.

	Line No.	Value
• Time and date menu		
Set the time	Time / minute (1)	HH.MM
Set the date	Day / month (2)	DD.MM
Set the year	Year (3)	YYYY
• Configuration menu		
Start up the heating circuit 1	Heating circuit 1 (5710)	On
Configure pump Q15	Output via relay QX2 (5891)	Pump for circulation circuit 1 Q15
Configure input H1	Input function H1 (5891)	Demand for circulation circuit 1
Configure extension module 1	Function of extension module 1 (6020)	Heating circuit 1
• Heating circuit 1 menu		
Set the comfort setting	Comfort setting temperature (710)	---
Set the curve slope	Heating curve slope (720)	---
• Circulation circuit 1 menu		
Set the starting value to use in the event of demand from the circulation circuit	Value of starting temperature for circulation circuit demand (1859)	---
• Switch the heating mode to permanent comfort		

E. ELECTRICAL AND HYDRAULIC VALIDATION

	Line No.	Value
• Input/output test menu		
Check the outputs		
Alarm relay	Relay test (7700)	Relay output QX1
Constant circuit pump	Relay test (7700)	Relay output QX2
Opening V3V CC	Relay test (7700)	Relay output QX21 module 1
Closing V3V CC	Relay test (7700)	Relay output QX22 module 1
CC pump	Relay test (7700)	Relay output QX23 module 1
Reset outputs	Relay test (7700)	No test

Diagram VX120

	<i>Line No.</i>	<i>Value</i>
Check sensor values		
External sensor B9	External T° B9 (7730)	in °C
Flow sensor B1	Temperature sensor BX21 module 1 (7830)	in °C
• <i>Configuration</i> menu		
Check the hydraulic diagram	Generator 1 check (6212)	14
	Generator 2 check (6213)	0
	Information on DHW (6215)	0
	Information on heating circuits 3, 2 and 1 (6217)	3

F. OPTIMISATION OF SETTINGS

	<i>Line No.</i>	<i>Value</i>
• <i>Heating circuit 1</i> menu		
Set the reduced setting	Reduced temperature setting (712)	---
• <i>CC1 time programme</i> menu		
Preselection	Preselection (500)	---
Adjust the time programme	On / Off phases (501...506)	---
• <i>Circuit CC1 holiday</i> menu		
Preselection	Preselection (641)	---
Adjust the time programme	On / Off phases (642-643)	---
• Switch the heating mode to automatic		AUTO

Maintenance optimisation:

It is possible to generate a maintenance message without harming the boiler. This maintenance message may appear when the 3 following meters have elapsed:

- Time since last maintenance (or commissioning): set parameter 7044 to 12 months
- Operating hours of the burner (parameter 7040)
- Number of start-ups (parameter 7042)

The last 2 parameters depend on the boiler room's hydraulic installation. It is recommended to use at least parameter 7044 for yearly maintenance.

<p>BOILERS IN A CASCADE CONFIGURATION <i>1 direct network, no communication with the secondary network</i></p>	<p>Diagram VX200 VX201 page 1 / 6</p>
--	--

A. MAIN AND ALTERNATIVE HYDRAULIC DIAGRAMS

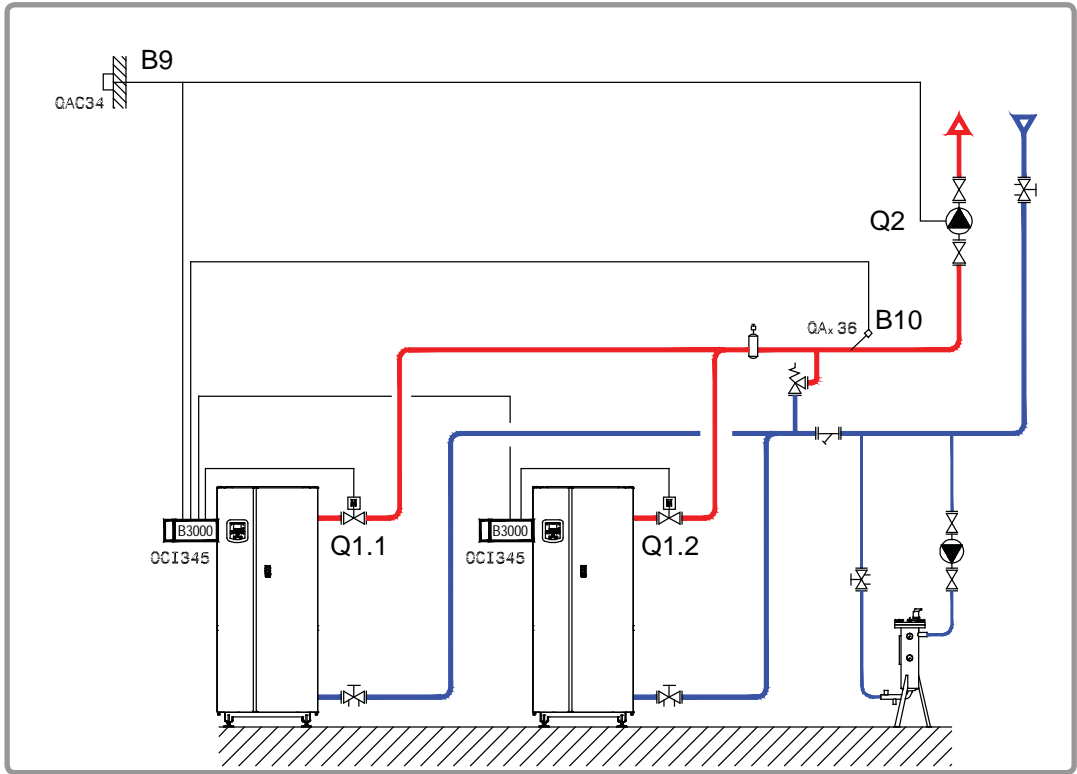

figure 61 - Diagram VX200

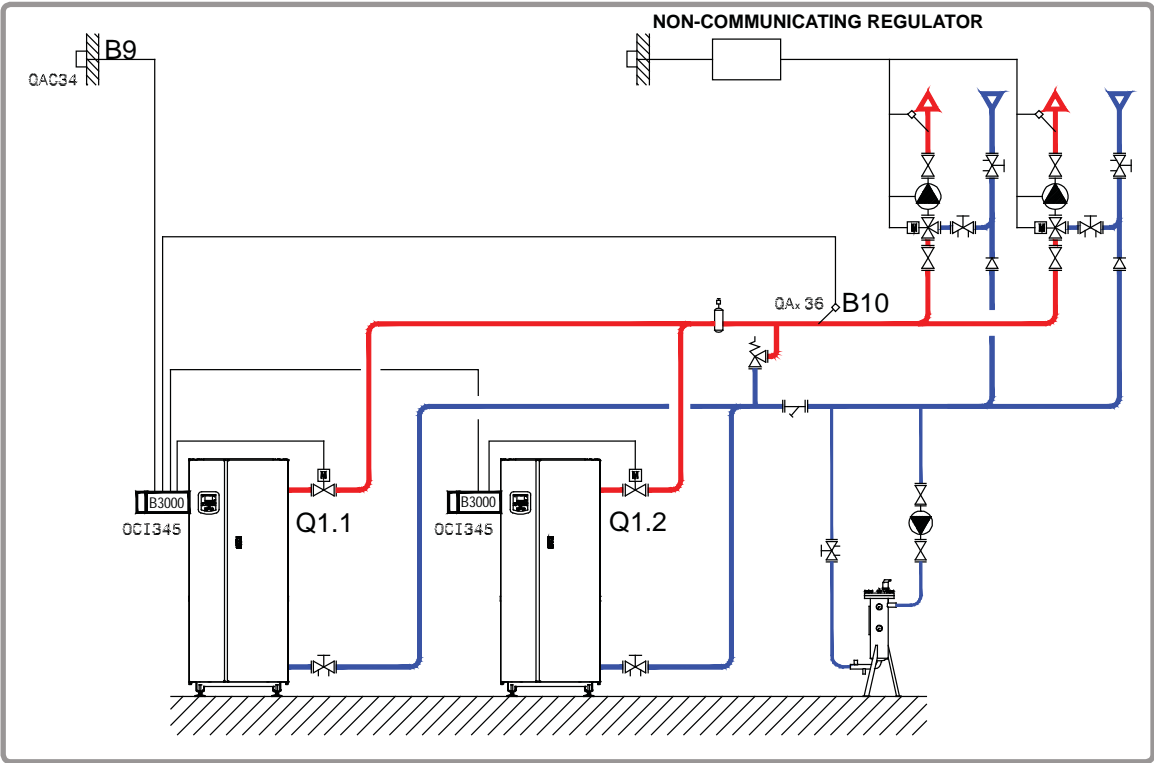

figure 62 - Diagram VX201 (alternative)

B. NECESSARY ADJUSTMENT ACCESSORIES

	Quantity	Appliance reference	Order No.
Communication kit	2	OCI 345	059572
Network sensor kit	1	QAx 36	059261 (QAZ 36) 059592 (QAD 36)
External sensor kit	1	QAC 34	059260

C. CUSTOMER ELECTRICAL CONNECTION

Boiler No. 1:

i

INFORMATION: If the insulating valve is not fitted with an automatic reset, reconnect the Q1.1 insulating valve closing contact on Y2.

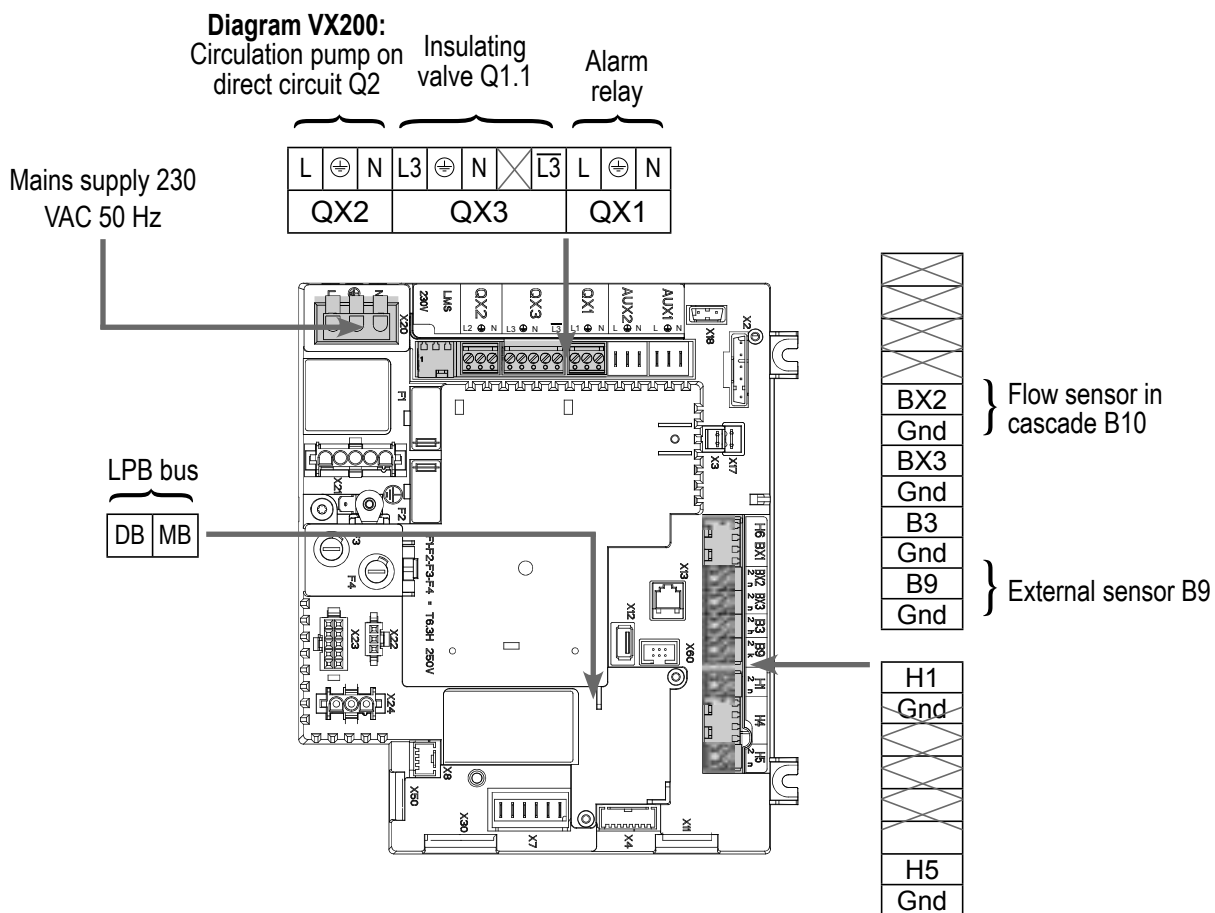

Boiler No. 2:

i

INFORMATION: If the insulating valve is not fitted with an automatic reset, reconnect the Q1.2 insulating valve closing contact on Y2.

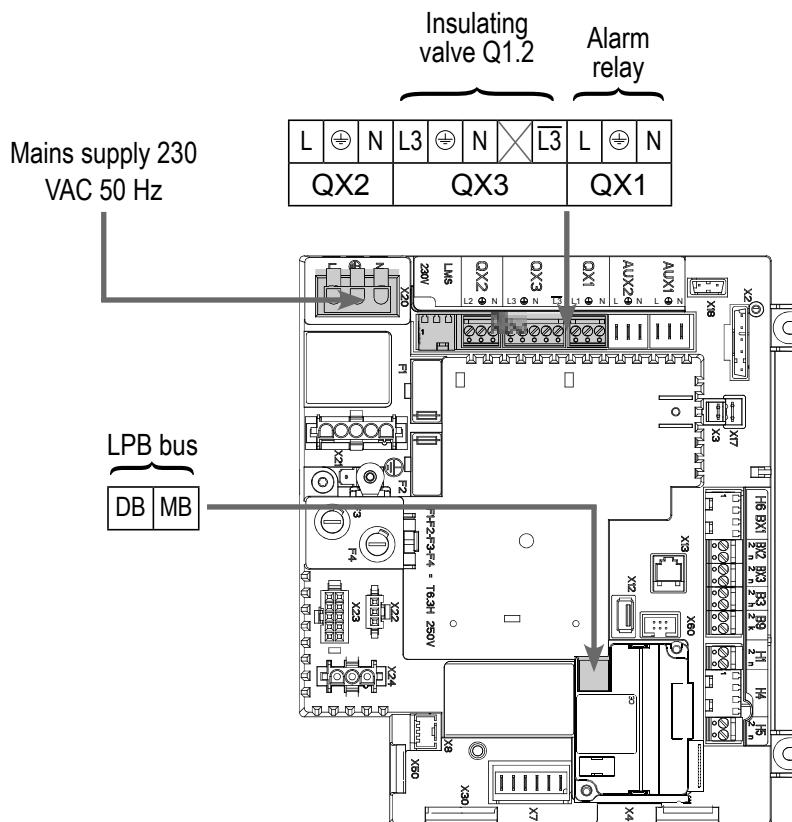

D. SPECIFIC START-UP PROCEDURE

- ☞ Fit the accessories and make their electrical connections.
- ☞ Start up the boiler alone.
- ☞ Make the following settings:

On boiler No. 1: master

	Line No.	Value
• Set the time and date: <i>Time and date</i> menu		
Set the time	Time / minute (1)	HH.MM
Set the date	Day / month (2)	DD.MM
Set the year	Year (3)	YYYY
• <i>Configuration</i> menu		
Start up the heating circuit 1	Heating circuit 1 (5710)	On
<i>Diagram VX200 only:</i>		
Configure the pump Q2	QX2 relay outlet (5891)	Pump CC1 Q2
<i>All diagrams:</i>		
Configure flow sensor in cascade B10	Sensor input BX2 (5931)	Common flow sensor B10

	<i>Line No.</i>	<i>Value</i>
• Configure as master in the cascade: <i>LPB network</i> menu		
Appliance number	Appliance address (6600)	1
Segment number	Segment address (6601)	0
Set the bus power supply.	Bus supply function (6604)	Automatic
Set the clock mode	Clock function (6640)	Master
• Set the heating circuit: <i>Heating circuit 1</i> menu		
Set the comfort setting	Comfort setting temperature (710)	---
Set the curve slope	Heating curve slope (720)	---

- Switch the heating mode to permanent comfort



On boiler(s) No. 2 (and later): slave

	<i>Line No.</i>	<i>Value</i>
• Configure as slave in the cascade: <i>LPB network</i> menu		
Appliance number	Appliance address (6600)	2 (or later for the other slaves)
Segment number	Segment address (6601)	0
Set the bus power supply.	Bus supply function (6604)	Automatic
Set the clock mode	Clock function (6640)	Slave without adjustment

- Connect the bus between the boilers (⚠ respect the polarity).
- Turn off the slave boiler(s) and then turn on again. If communication is successful, the clock is correctly updated.

E. ELECTRICAL AND HYDRAULIC VALIDATION

On boiler No. 1: master

	<i>Line No.</i>	<i>Value</i>
• <i>Cascade diagnostic</i> menu		
Check that all boilers are present in the cascade		
	Status of generator 1 (8100)	Released / not released
	Status of generator 2 (8101)	Released / not released
	

	Line No.	Value
• Input/output test menu		
Check the outputs		
Alarm relay	Relay test (7700)	Relay output QX1
Pump Q2 (diagram VX200)	Relay test (7700)	Relay output QX2
Insulating valve Q1.1	Relay test (7700)	Relay output QX3
Reset outputs	Relay test (7700)	No test
Check sensor values		
External sensor B9	External T° B9 (7730)	in °C
Flow sensor in cascade B10	Sensor T° BX2 (7821)	in °C
• Configuration menu		
Check the hydraulic diagram	Generator 1 check (6212)	14
	Generator 2 check (6213)	0
	Information on DHW (6215)	0
	Information on heating circuits 3, 2 and 1 (6217)	1

On boiler(s) No. 2 (and later): slave

	Line No.	Value
• Input/output test menu		
Check the outputs		
Alarm relay	Relay test (7700)	Relay output QX1
Insulating valve Q1.2	Relay test (7700)	Relay output QX3
Reset outputs	Relay test (7700)	No test
• Configuration menu		
Check the hydraulic diagram	Generator 1 check (6212)	14
	Generator 2 check (6213)	0
	Information on DHW (6215)	0
	Information on heating circuits 3, 2 and 1 (6217)	0

F. OPTIMISATION OF SETTINGS

On boiler No. 1: master

Optimisation of heating circuit:

	Line No.	Value
<ul style="list-style-type: none"> • Heating circuit 1 menu <ul style="list-style-type: none"> Set the reduced setting Reduced temperature setting (712) 		---
<ul style="list-style-type: none"> • CC1 time programme menu <ul style="list-style-type: none"> Preselection Preselection (500) Adjust the time programme On / Off phases (501...506) 		---
<ul style="list-style-type: none"> • Circuit CC1 holiday menu <ul style="list-style-type: none"> Preselection Preselection (641) Adjust the time programme On / Off phases (642-643) 		---
<ul style="list-style-type: none"> • Switch the heating mode to automatic 		AUTO

Optimisation of the cascade:

The cascade may be optimised as required with the parameters of the **Cascade** menu. Refer to the LMS boiler command table instructions for more details.

Maintenance optimisation:

It is possible to generate a maintenance message without harming the boiler. This maintenance message may appear when the 3 following meters have elapsed:

- Time since last maintenance (or commissioning): set parameter 7044 to 12 months
- Operating hours of the burner (parameter 7040)
- Number of start-ups (parameter 7042)

The last 2 parameters depend on the boiler room's hydraulic installation. It is recommended to use at least parameter 7044 for yearly maintenance.

B. NECESSARY ADJUSTMENT ACCESSORIES

	Quantity	Appliance reference	Order No.
Extension module kit (delivered with a QAD 36 network sensor)	1	AVS 75	059751
Communication kit	2	OCI 345	059572
Network sensor kit	1	QAx 36	059261 (QAZ 36) 059592 (QAD 36)
DHW sensor kit (diagram VX210)	1	QAZ 36	059261
External sensor kit	1	QAC 34	059260

C. CUSTOMER ELECTRICAL CONNECTION

Boiler No. 1:



INFORMATION:

If the insulating valve is not fitted with an automatic reset, reconnect the Q1.1 insulating valve closing contact on Y2.

Diagram VX210: DHW circulation pump Q3
Diagram VX220: Direct circulation pump Q15

Insulating valve Q1.1
Alarm relay

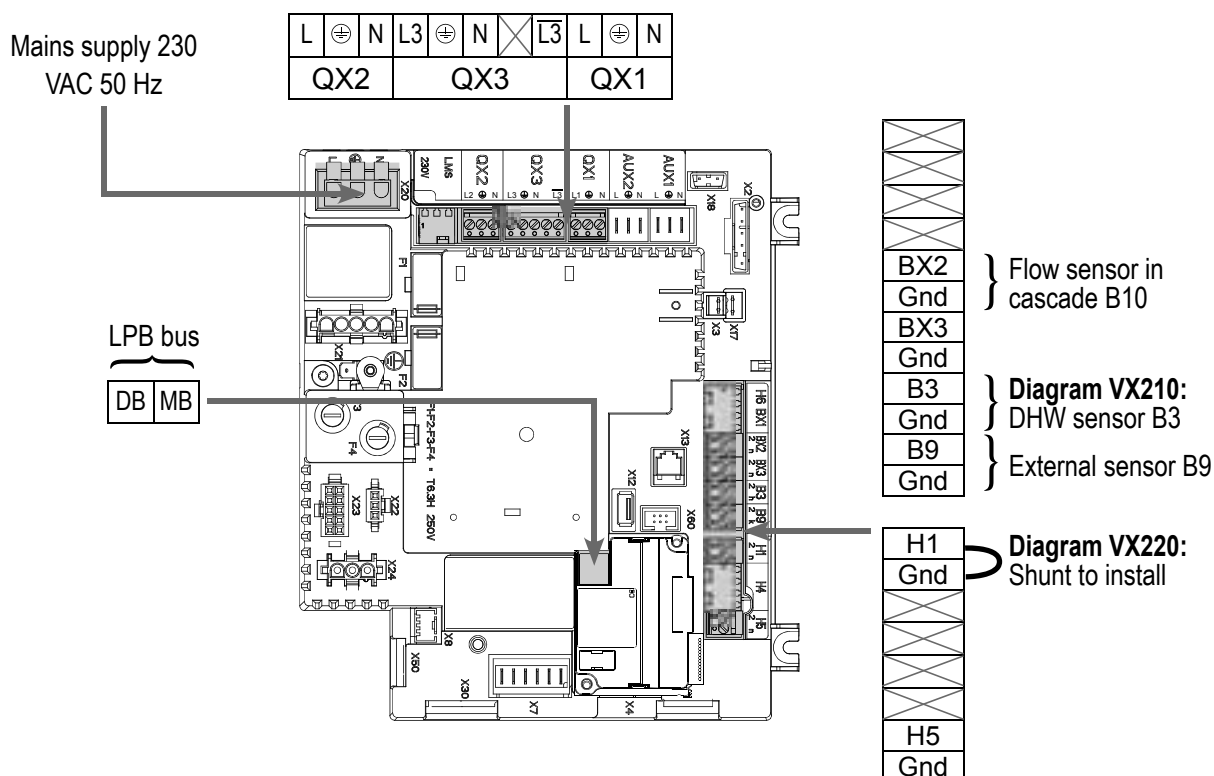

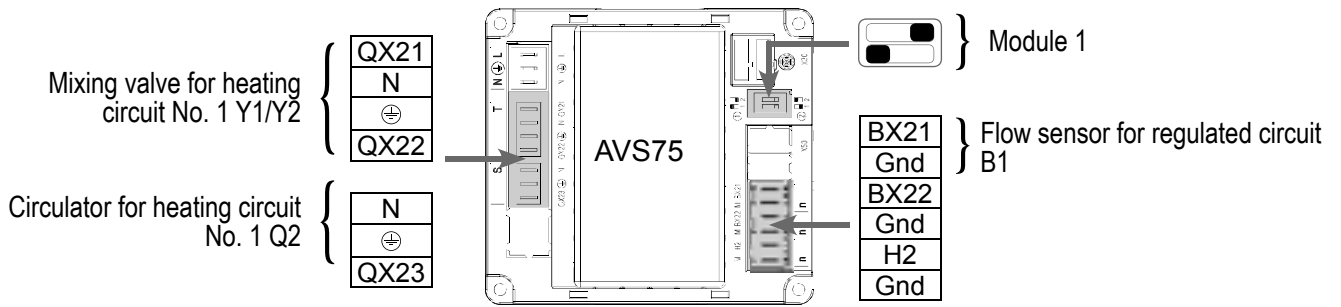

Boiler No. 2:



INFORMATION:

If the insulating valve is not fitted with an automatic reset, reconnect the Q1.2 insulating valve closing contact on Y2.

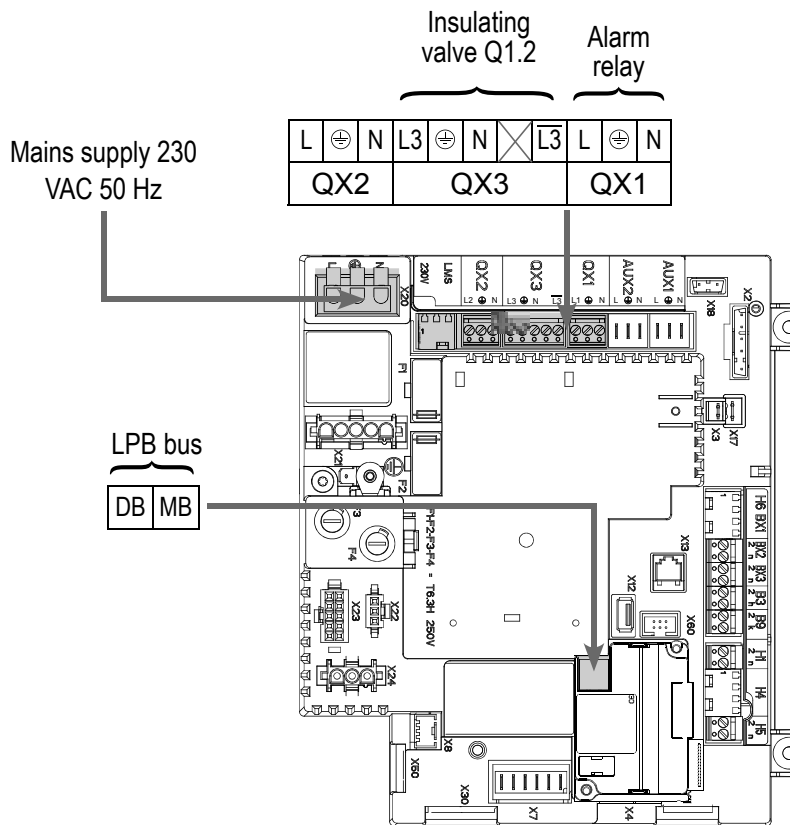

D. SPECIFIC START-UP PROCEDURE

☞ Fit the accessories and make their electrical connections.



WARNING:

Ensure the switches on extension module AVS75 are correctly configured.

☞ Start up the boiler alone.

☞ Make the following settings:

On boiler No. 1: master

	<i>Line No.</i>	<i>Value</i>
• Time and date menu		
Set the time	Time / minute (1)	HH.MM
Set the date	Day / month (2)	DD.MM
Set the year	Year (3)	YYYY
• Configuration menu		
Configure the DHW pump (<i>diagram VX210</i>)	QX2 relay outlet (5891)	Pump/valve ECS Q3
Configure pump Q15 (<i>diagram VX220</i>)	QX2 relay outlet (5891)	Pump for circulation circuit 1 Q15
Configure the flow sensor in cascade B10	Sensor input BX2 (5931)	Common flow sensor B10
Configure input H1 (<i>diagram VX220</i>)	Input function H1 (5977)	Demand for circulation circuit 1
Configure the extension module	Function of extension module 1 (6020)	Heating circuit 1
• Configure as master in the cascade: <u>LPB network</u> menu		
Appliance number	Appliance address (6600)	1
Segment number	Segment address (6601)	0
Set the bus power supply.	Bus supply function (6604)	Automatic
Set the clock mode	Clock function (6640)	Master
• Heating circuit 1 menu		
Set the comfort setting	Comfort setting temperature (710)	---
Set the curve slope	Heating curve slope (720)	---

• Switch the heating mode to permanent comfort



	<i>Line No.</i>	<i>Value</i>
Diagram VX210 only:		
• Domestic hot water menu		
Set the comfort setting	Comfort setpoint (1610)	---
• Activate DHW mode 		

Diagram VX220 only:		
• Circulation circuit 1 menu		
Set the starting value to use in the event of a demand from the circulation circuit	Value of starting temperature for circulation circuit demand (1859)	---

On boiler(s) No. 2 (and later): slave

• Configure as slave in the cascade: <u>LPB network</u> menu		
Appliance number	Appliance address (6600)	2 (or later for the other slaves)
Segment number	Segment address (6601)	0
Set the bus power supply.	Bus supply function (6604)	Automatic
Set the clock mode	Clock function (6640)	Slave without adjustment

- Connect the bus between the boilers ( respect the polarity).
- Turn off the slave boiler(s) and then turn on again. If communication is successful, the clock is correctly updated.

E. ELECTRICAL AND HYDRAULIC VALIDATION

On boiler No. 1: master

• Cascade diagnostic menu		
Check that all boilers are present in the cascade	Status of generator 1 (8100)	Released / not released
	Status of generator 2 (8101)	Released / not released

	Line No.	Value
• Input/output test menu		
Check the outputs		
Alarm relay	Relay test (7700)	Relay output QX1
DHW pump Q3 (<i>diagram VX210</i>)	Relay test (7700)	Relay output QX2
Constant circuit pump Q15 (<i>diagram VX220</i>)	Relay test (7700)	Relay output QX2
Opening V3V CC	Relay test (7700)	Relay output QX21 module 1
Closing V3V CC	Relay test (7700)	Relay output QX22 module 1
CC pump	Relay test (7700)	Relay output QX23 module 1
Reset outputs	Relay test (7700)	No test
Check sensor values		
External sensor B9	External T° B9 (7730)	in °C
DHW sensor B3	DHW temperature B3/B38 (7750)	in °C
Flow sensor B1	Temperature sensor BX21 module 1 (7830)	in °C
• Configuration menu		
Check the hydraulic diagram	Generator 1 check (6212)	14
	Generator 2 check (6213)	0
	Information on DHW (6215)	4 (<i>Diagram VX210</i>) 0 (<i>Diagram VX220</i>)
	Information on heating circuits 3, 2 and 1 (6217)	3

On boiler No. 2: slave

• Input/output test menu		
Check the outputs		
Alarm relay	Relay test (7700)	Relay output QX1
Insulating valve Q1.2	Relay test (7700)	Relay output QX3
Reset outputs	Relay test (7700)	No test

	Line No.	Value
• Configuration menu		
Check the hydraulic diagram	Generator 1 check (6212)	14
	Generator 2 check (6213)	0
	Information on DHW (6215)	0
	Information on heating circuits 3, 2 and 1 (6217)	0

F. OPTIMISATION OF SETTINGS

Optimisation of heating circuit:

• Heating circuit 1 menu		
Set the reduced setting	Reduced temperature setting (712)	---
• CC1 time programme menu		
Preselection	Preselection (500)	---
Adjust the time programme	On / Off phases (501...506)	---
• Circuit CC1 holiday menu		
Preselection	Preselection (641)	---
Adjust the time programme	On / Off phases (642-643)	---
• Switch the heating mode to automatic		AUTO

Optimisation of DHW:

• Domestic hot water menu		
Set the comfort setting	Reduced setting (1612)	---
Set the DHW release mode	DHW release (1620)	Time programme 4/ DHW
• Time programme 4 / DHW menu		
Preselection	Preselection (560)	---
Adjust the time programme	On / Off phases (561...566)	---
• DHW storage tank menu		
Adjust the boost	Starting value of boost temperature (5020)	---

	<i>Line No.</i>	<i>Value</i>
<i>Diagram VX210 only:</i>		
• <i>Domestic hot water</i> menu		
Configure an anti-legionella function	Anti-legionella function (1640)	---
	Periodic anti-legionella function (1641)	---
	Day week anti-legionella function (1642)	---
	Anti-legionella temperature setting (1645)	---
	Duration of anti-legionella function (1646)	---

Optimisation of the cascade:

The cascade may be optimised as required with the parameters of the **Cascade** menu. Refer to the LMS boiler command table instructions for more details.

Maintenance optimisation:

It is possible to generate a maintenance message without harming the boiler. This maintenance message may appear when the 3 following meters have elapsed:

- Time since last maintenance (or commissioning): set parameter 7044 to 12 months
- Operating hours of the burner (parameter 7040)
- Number of start-ups (parameter 7042)

The last 2 parameters depend on the boiler room's hydraulic installation. It is recommended to use at least parameter 7044 for yearly maintenance.

<p>BOILERS IN A CASCADE CONFIGURATION</p> <p><i>Secondary networks regulated by external regulated communicating by LPB bus or 0...10V</i></p>	<p>Diagram VX211 page 1 / 6</p>
---	--

A. HYDRAULIC DIAGRAM

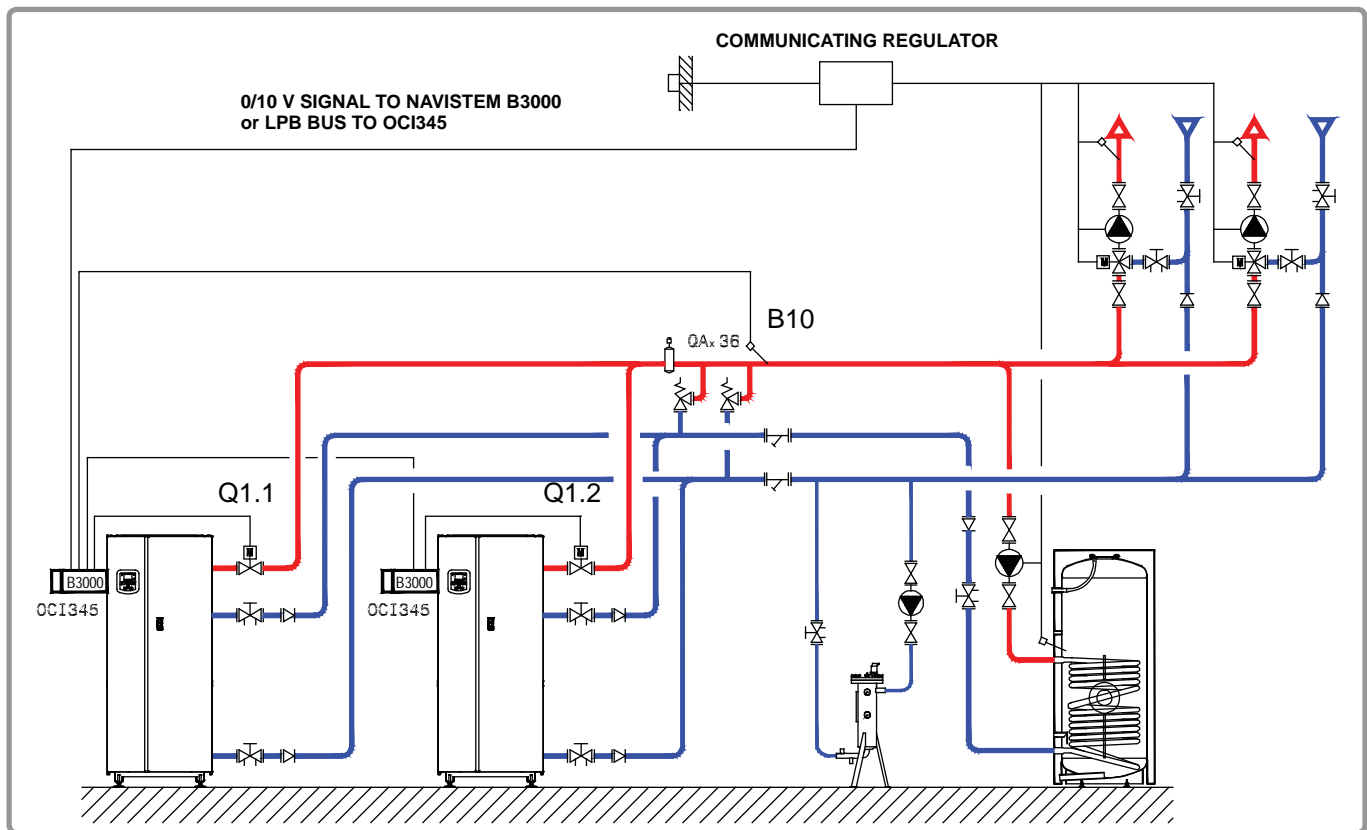

figure 65 - Diagram VX211

B. NECESSARY ADJUSTMENT ACCESSORIES

	Quantity	Appliance reference	Order No.
Communication kit	2	OCI 345	059572
Network sensor kit	1	QAx 36	059261 (QAZ 36) 059592 (QAD 36)

Diagram VX211	page 2 / 6
----------------------	------------

C. CUSTOMER ELECTRICAL CONNECTION

Boiler No. 1:

i

INFORMATION: If the insulating valve is not fitted with an automatic reset, reconnect the Q1.1 insulating valve closing contact on Y2.

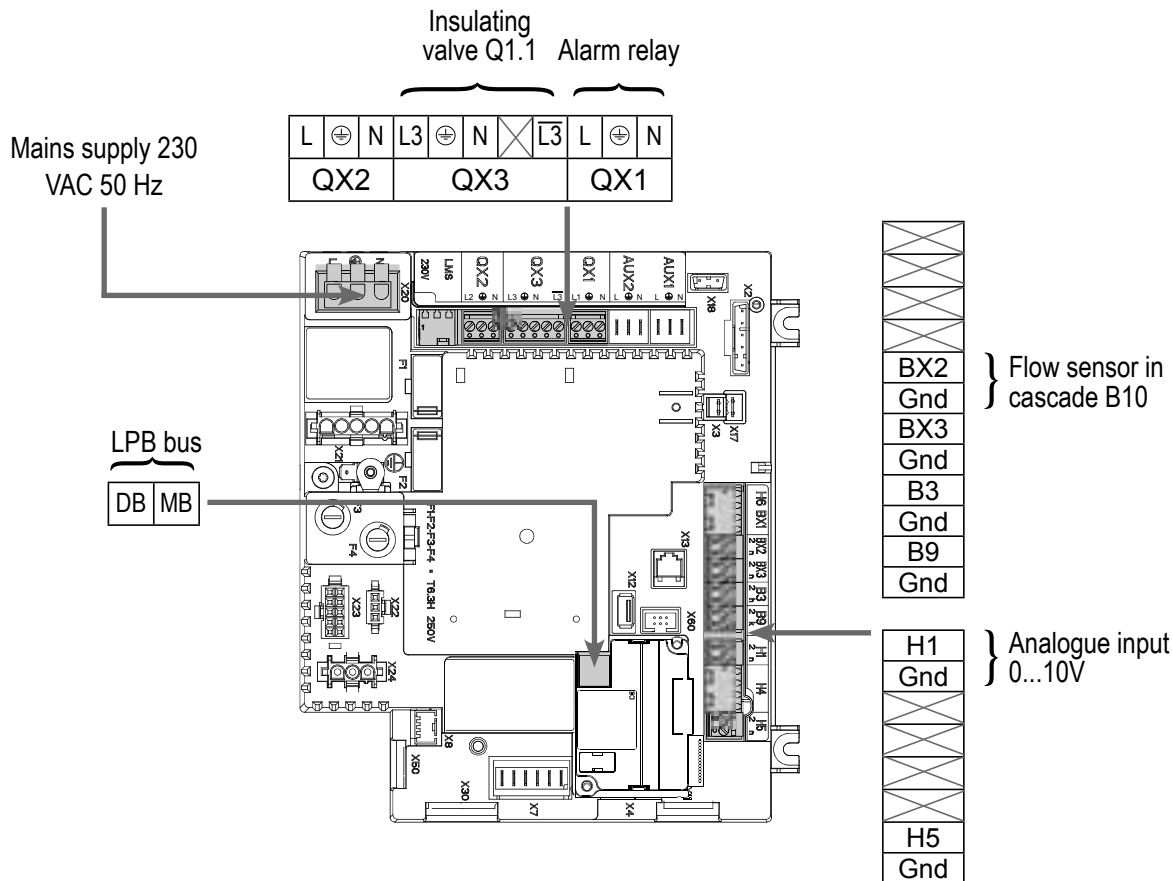

Boiler No. 2:

i

INFORMATION: If the insulating valve is not fitted with an automatic reset, reconnect the Q1.2 insulating valve closing contact on Y2.

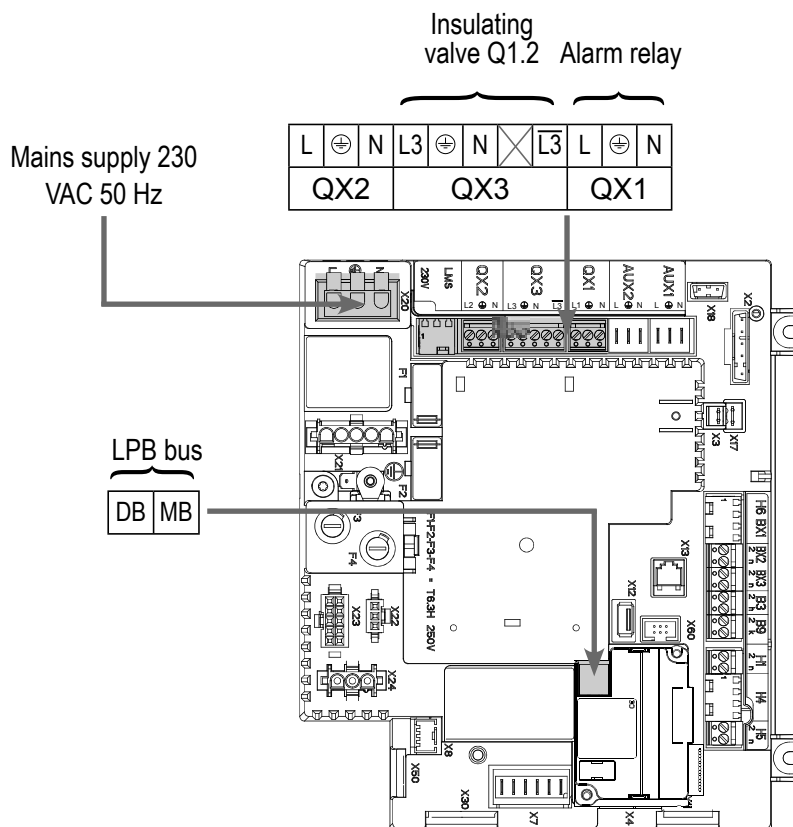

D. SPECIFIC START-UP PROCEDURE

- ☞ Fit the accessories and make their electrical connections.
- ☞ Start up the boiler alone.
- ☞ Make the following settings:

On boiler No. 1: master

- **Time and date menu**

Set the time

Time / minute (1)

HH.MM

Set the date

Day / month (2)

DD.MM

Set the year

Year (3)

YYYY

- **Configuration menu**

Configure the flow sensor in cascade B10

Sensor input BX2 (5931)

Common flow sensor B10

For a demand via input 0...10V

Configure input H1

Input function H1 (5950)

Demand from circulation circuit
1 10V

Voltage value 1 H1 (5953)

0.0

Line No. Value

Function value H1 (5954)	0
Voltage value 2 H1 (5955)	10.0
Function value 2 H1 (5956)	1000 (for 10 V = 100 °C equivalence)

For a demand via LPB

Check that the secondary regulator is defined on a LPB segment other than 0 (reserved for generators)

In all events (LPB network menu)

Configure the boiler as master in the cascade

Appliance address (6600)	1
Segment address (6601)	0
Bus supply function (6604)	Automatic
Clock function (6640)	Master

On boiler(s) No. 2 (and later): slave

• **LPB network menu**

Configure the boiler as slave in the cascade

Appliance address (6600)	2 (or later for the other slaves)
Segment address (6601)	0
Bus supply function (6604)	Automatic
Clock function (6640)	Slave without adjustment

- Connect the bus between the boilers (⚠ respect the polarity).
- Turn off the slave boiler(s) and then turn on again. If communication is successful, the clock is correctly updated.

E. ELECTRICAL AND HYDRAULIC VALIDATION

On boiler No. 1: master

• **Cascade diagnostic** menu

Check that all boilers are present in the cascade

Status of generator 1 (8100)	Released / not released
Status of generator 2 (8101)	Released / not released
.....	

Diagram VX211

	Line No.	Value
For a demand via input 0...10V		
• Input/output test menu		
Voltage in H1	Voltage signal H1 (7840)	To validate with the voltage sent by the boiler room machine
For a demand via LPB		
If the boiler room regulator is configured as the slave clock, it must recover the date and time.		
• Input/output test menu		
Check the outputs		
Alarm relay	Relay test (7700)	Relay output QX1
Insulating valve Q1.1	Relay test (7700)	Relay output QX3
Reset outputs	Relay test (7700)	No test
Check sensor values		
External sensor B9	External T° B9 (7730)	in °C
Flow sensor B1	Sensor T° BX2 (7821)	in °C
• Configuration menu		
Check the hydraulic diagram		
	Generator 1 check (6212)	14
	Generator 2 check (6213)	0
	Information on DHW (6215)	0
	Information on heating circuits 3, 2 and 1 (6217)	0
On boiler No. 2: slave		
• Input/output test menu		
Check the outputs		
Alarm relay	Relay test (7700)	Relay output QX1
Insulating valve Q1.2	Relay test (7700)	Relay output QX3
Reset outputs	Relay test (7700)	No test

Diagram VX211

page 6 / 6

	Line No.	Value
• Configuration menu		
Check the hydraulic diagram	Generator 1 check (6212)	14
	Generator 2 check (6213)	0
	Information on DHW (6215)	0
	Information on heating circuits 3, 2 and 1 (6217)	0

F. OPTIMISATION OF SETTINGS

Optimisation of the cascade:

The cascade may be optimised as required with the parameters of the **Cascade** menu. Refer to the LMS boiler command table instructions for more details.

Maintenance optimisation:

It is possible to generate a maintenance message without harming the boiler. This maintenance message may appear when the 3 following meters have elapsed:

- Time since last maintenance (or commissioning): set parameter 7044 to 12 months
- Operating hours of the burner (parameter 7040)
- Number of start-ups (parameter 7042)

The last 2 parameters depend on the boiler room's hydraulic installation. It is recommended to use at least parameter 7044 for yearly maintenance.

<h2 style="margin: 0;">BOILERS IN A CASCADE CONFIGURATION</h2> <p style="margin: 0;"><i>3 or 4 networks regulated by a three-channel valve with or without DHW production</i></p>	<p>Diagram VX202 VX212 page 1 / 9</p>
---	---

A. MAIN AND ALTERNATIVE HYDRAULIC DIAGRAMS

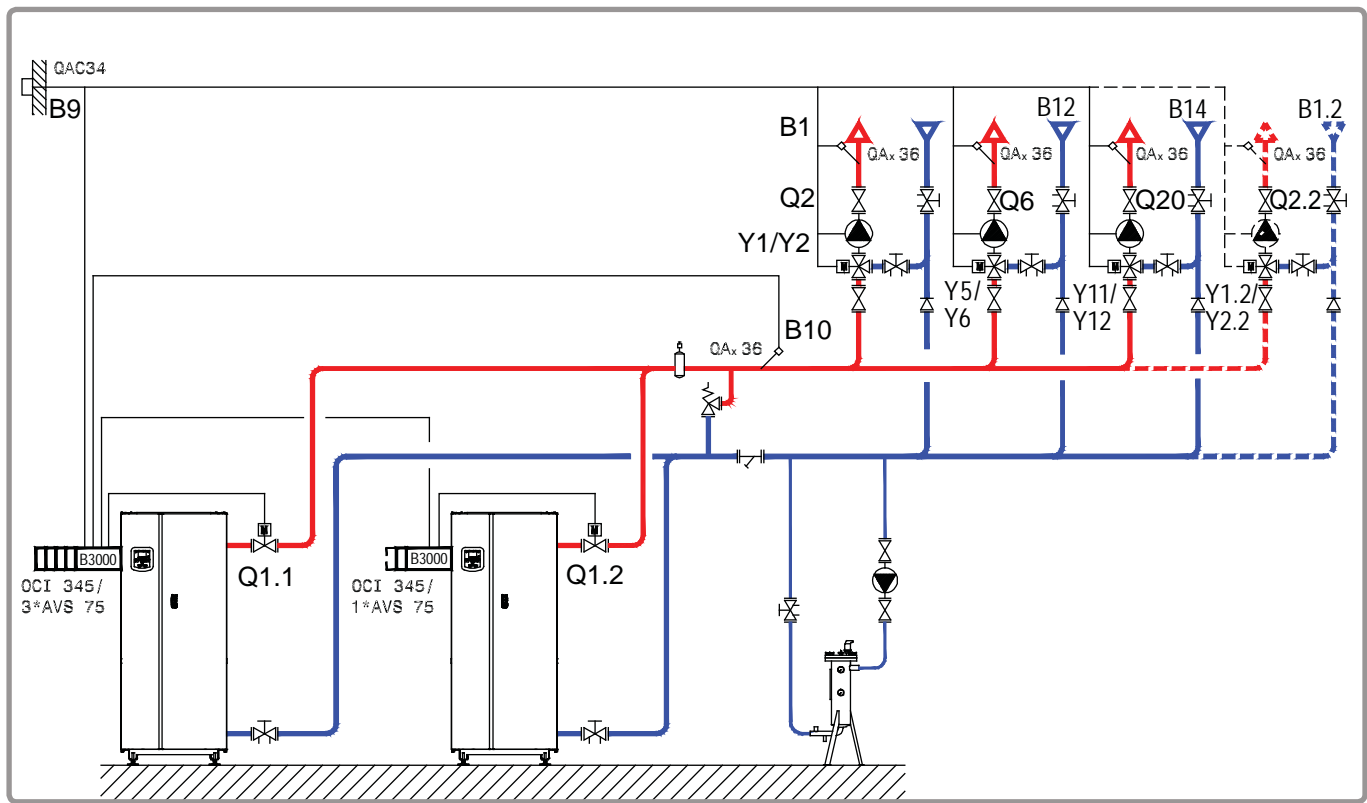

figure 66 - Diagram VX202

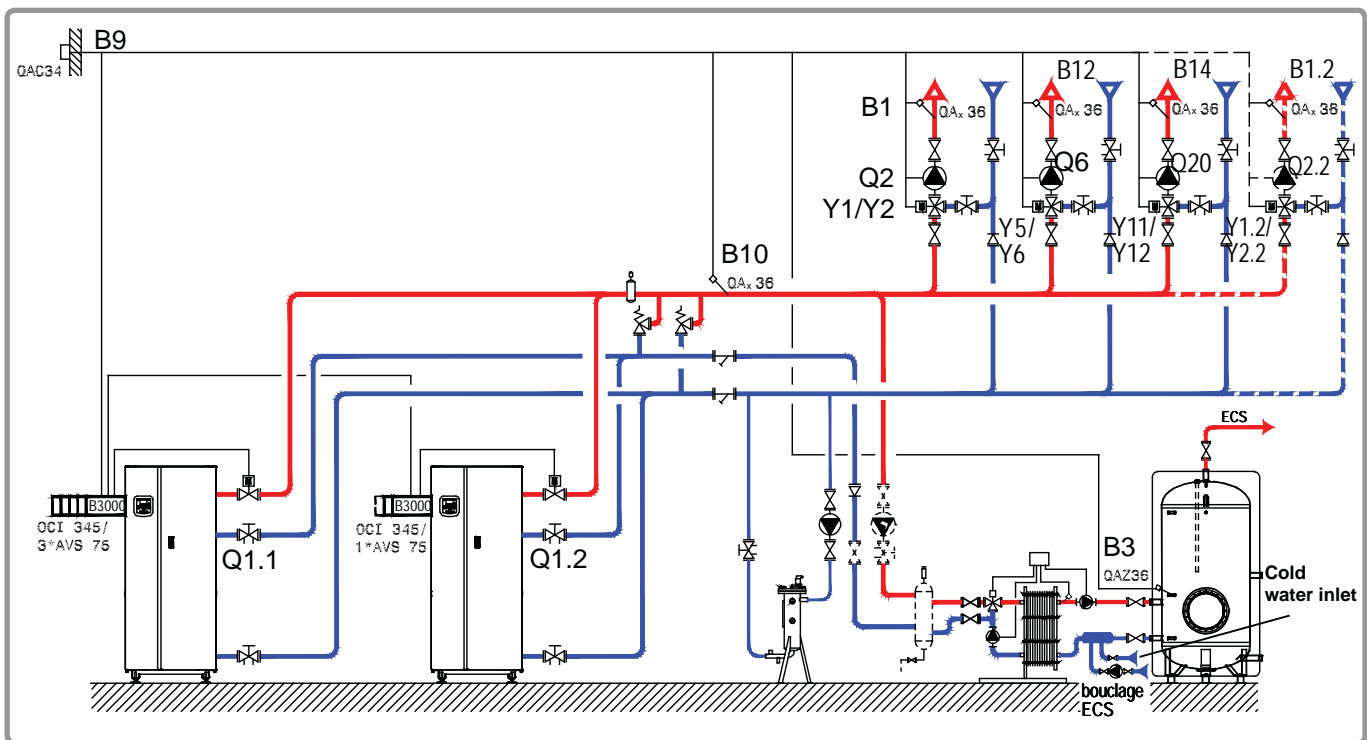

figure 67 - Diagram VX212 (alternative)

B. NECESSARY ADJUSTMENT ACCESSORIES

	Quantity	Appliance reference	Order No.
Extension module kit (delivered with a QAD 36 network sensor)	3 (4)	AVS 75	059751
Communication kit	2	OCI 345	059572
Network sensor kit	1	QAx 36	059261 (QAZ 36) 059592 (QAD 36)
External sensor kit	1	QAC 34	059260
DHW sensor kit (diagram VX212)	1	QAZ 36	059261

C. CUSTOMER ELECTRICAL CONNECTION

Boiler No. 1:

INFORMATION: If the insulating valve is not fitted with an automatic reset, reconnect the Q1.1 insulating valve closing contact on Y2.

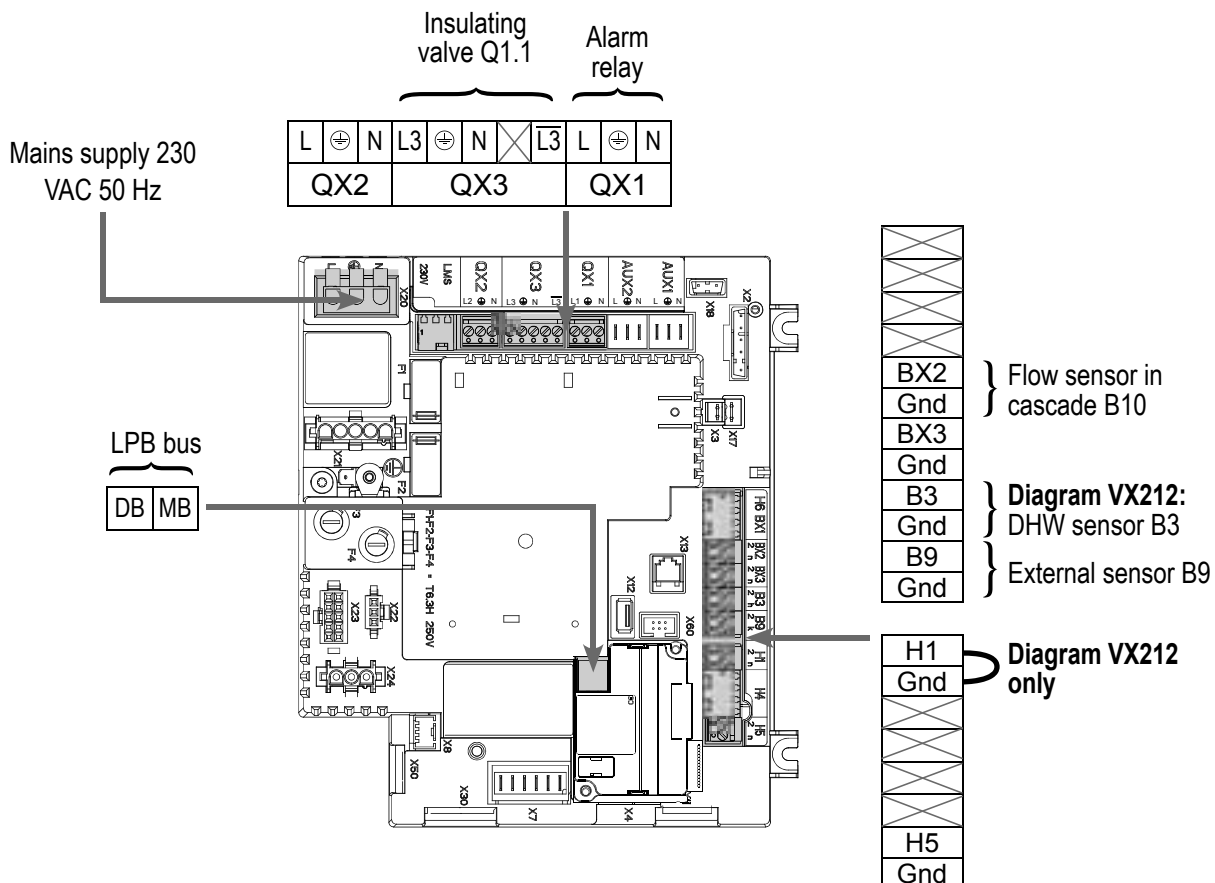

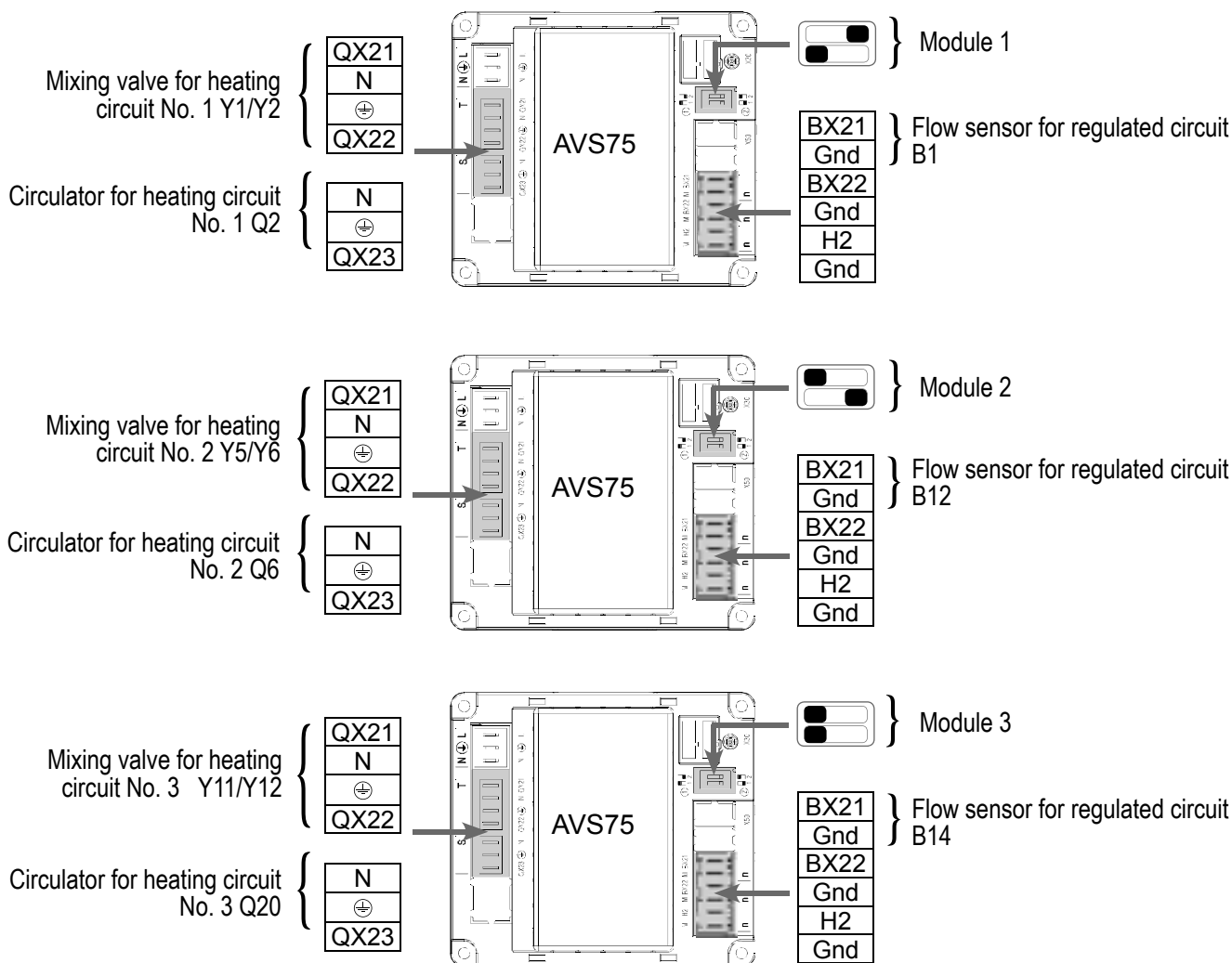

Boiler No. 2:



INFORMATION:

If the insulating valve is not fitted with an automatic reset, reconnect the Q1.2 insulating valve closing contact on Y2.

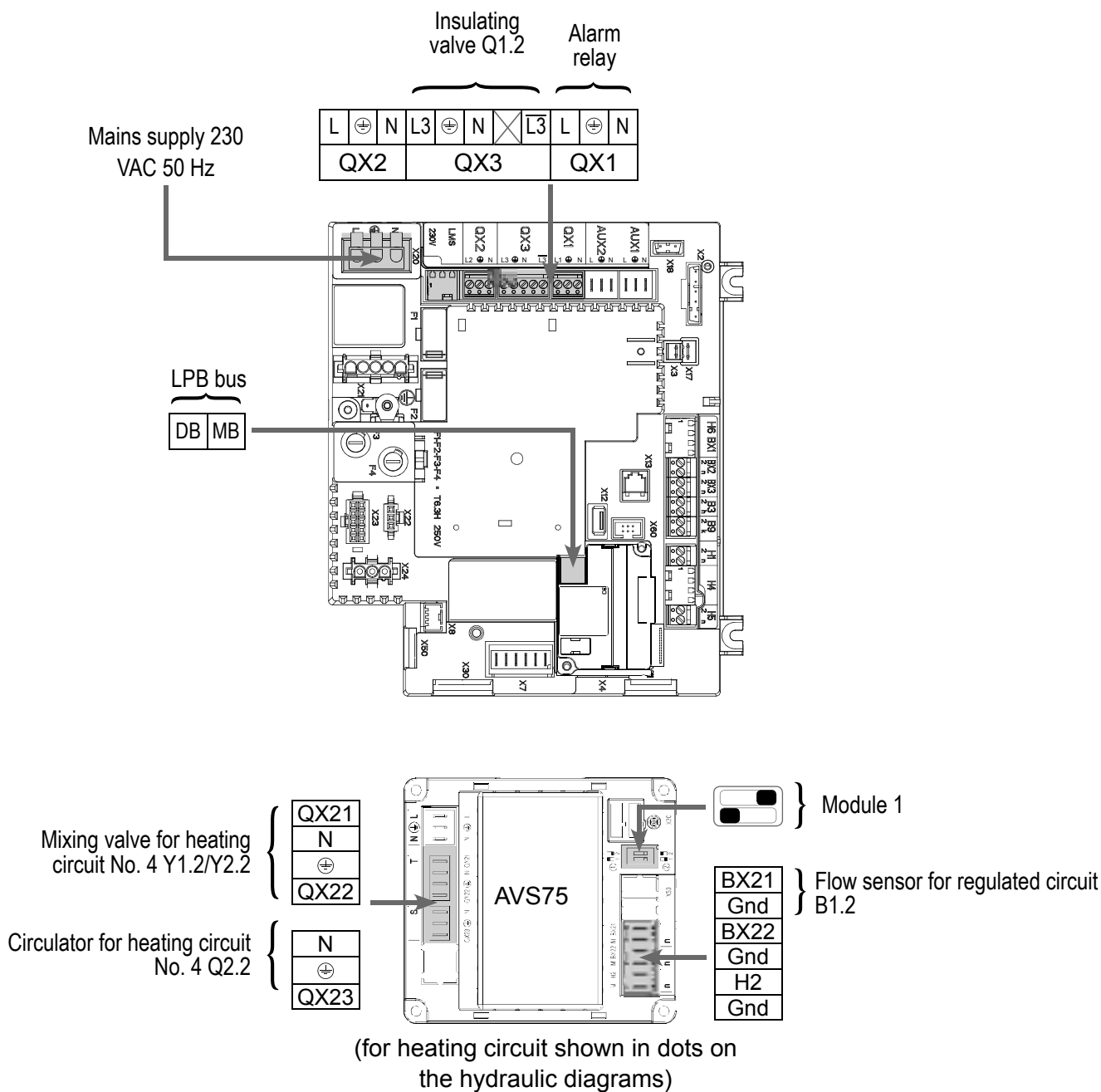

D. SPECIFIC START-UP PROCEDURE

Fit the accessories and make their electrical connections.

WARNING: Ensure the switches on the extension modules AVS75 are properly configured.

- Start up the boiler alone.
- Make the following settings.

On boiler No. 1: master

	<i>Line No.</i>	<i>Value</i>
• Time and date menu		
Set the time	Time / minute (1)	HH.MM
Set the date	Day / month (2)	DD.MM
Set the year	Year (3)	YYYY
• Configuration menu		
Start up the heating circuit 1	Heating circuit 2 (5710)	On
Start up the heating circuit 2	Heating circuit 2 (5715)	On
Start up the heating circuit 3	Heating circuit 3 (5721)	On
Diagram VX212 only:		
Define a low level	Input function H1 (5950)	Circulation circuit demand 1
Install a shunt on H1 OR reverse the direction of contact	Type of contact (5951)	Rest contact
For the DHW to be effective, it is necessary to define a trigger, even if it is not connected.	QX2 relay outlet (5891)	Pump/valve ECS Q3
Configure pump Q1	Relay output QX3 (5892)	Boiler pump Q1
Configure flow sensor in cascade B10	Sensor input BX2 (5931)	Common flow sensor B10
Configure the extension modules	Function of extension module 1 (6020)	Heating circuit 1
	Function of extension module 2 (6021)	Heating circuit 2
	Function of extension module 3 (6022)	Heating circuit 3
• Configure as master in the cascade: LPB network menu		
Appliance number	Appliance address (6600)	1
Segment number	Segment address (6601)	0
Set the bus power supply.	Bus supply function (6604)	Automatic
Set the clock mode	Clock function (6640)	Master
• Heating circuit 1 / 2 / 3 menu		
Set the comfort setting	Temperature of comfort setting (710/1010/1310)	---
Set the curve slope	Slope of the heating curve (720/1020/1320)	---

- Switch the heating mode to permanent comfort



	<i>Line No.</i>	<i>Value</i>
Diagram VX212 only:		
<ul style="list-style-type: none"> • Circulation circuit 1 menu <p style="margin-left: 20px;">Set the starting value to use in the event of a demand from the circulation circuit</p>	<p>Starting value in case of circuit demand (1859)</p>	<p>60°C (depends on Rubis setting)</p>
<ul style="list-style-type: none"> • Domestic hot water menu <p style="margin-left: 20px;">Set the comfort setting</p> <p style="margin-left: 20px;">Set the DHW release mode</p>	<p>Comfort setpoint (1610)</p> <p>DHW release (1620)</p>	<p>55 °C</p> <p>24/7</p>
<ul style="list-style-type: none"> • Activate DHW mode 		

On boiler(s) No. 2 (and later): slave

<ul style="list-style-type: none"> • Configuration menu <p style="margin-left: 20px;">If there is a 4th heating circuit: Start up the heating circuit 1</p>		
Configure the extension module	Heating circuit 1 (5710)	On
	Function of extension module 1 (6020)	Heating circuit 1
<ul style="list-style-type: none"> • Configure as slave in the cascade: LPB network menu 		
Appliance number	Appliance address (6600)	2 (or later for the other slaves)
Segment number	Segment address (6601)	0
Set the bus power supply.	Bus supply function (6604)	Automatic
Set the clock mode	Clock function (6640)	Slave without adjustment

If there is a 4th heating circuit:

<ul style="list-style-type: none"> • Set the heating circuit: Heating circuit 1 menu 		
Set the comfort setting	Comfort setting temperature (710)	---
Set the curve slope	Heating curve slope (720)	---
<ul style="list-style-type: none"> • Switch the heating mode to permanent comfort 		

- Connect the bus between the boilers (⚠ respect the polarity).
- Turn off the slave boiler(s) and then turn on again. If communication is successful, the clock is correctly updated.

E. ELECTRICAL AND HYDRAULIC VALIDATION

On boiler No. 1: master

	Line No.	Value
<ul style="list-style-type: none"> • Cascade diagnostic menu 		
<p style="margin-left: 20px;">Check that all boilers are present in the cascade</p>		
Status of generator 1 (8100)		Released / not released
Status of generator 2 (8101)		Released / not released
.....		
<ul style="list-style-type: none"> • Input/output test menu 		
<p style="margin-left: 20px;">Check the outputs</p>		
Alarm relay	Relay test (7700)	Relay output QX1
Insulating valve Q1.1	Relay test (7700)	Relay output QX3
All relays of extension modules	Relay test (7700)	Relay output QX2... module...
Reset outputs	Relay test (7700)	No test
<p style="margin-left: 20px;">Check sensor values</p>		
External sensor B9	External T° B9 (7730)	in °C
DHW sensor B3 (diagram VX212)	DHW temperature B3/B8 (7750)	in °C
Flow sensor in cascade B10	Sensor T° BX2 (7821)	in °C
Flow sensor B1	Temperature sensor BX21 module 1 (7830)	in °C
Flow sensor B12	Temperature sensor BX21 module 2 (7832)	in °C
Flow sensor B14	Temperature sensor BX21 module 3 (7834)	in °C
<p style="margin-left: 20px;">Diagram VX212 only:</p>		
Check the status of contact H1	Status of contact H1 (7841)	Closed if the shunt is in place
<ul style="list-style-type: none"> • Configuration menu 		
Check the hydraulic diagram	Generator 1 check (6212)	14
	Generator 2 check (6213)	0
	Information on DHW (6215)	0 (<i>diagram VX202</i>) 4 (<i>diagram VX212</i>)
	Information on heating circuits 3, 2 and 1 (6217)	30303

On boiler(s) No. 2 (and later): slave

	Line No.	Value
• Input/output test menu		
Check the outputs		
Alarm relay	Relay test (7700)	Relay output QX1
Insulating valve Q1.2	Relay test (7700)	Relay output QX3
Reset outputs	Relay test (7700)	No test
Check the values of the sensors (if 4th heating circuit present)		
Flow sensor B1.2	Temperature sensor BX21 module 1 (7830)	in °C
• Configuration menu		
Check the hydraulic diagram		
	Generator 1 check (6212)	14
	Generator 2 check (6213)	0
	Information on DHW (6215)	0
	Information on heating circuits 3, 2 and 1 (6217)	3 (if 4th heating circuit present)

F. OPTIMISATION OF SETTINGS

On master and slave boilers

Optimisation of the heating circuits:

• Heating circuit 1 / 2 / 3 menu		
Set the reduced setting	Reduced temperature value (712/1012/1312)	---
• Time programme CC1 / CC2 / CC3 menu		
Preselection	Preselection (500/520/540)	---
Adjust the time programme	On / Off phases (501...506) (521...526) (541...546)	---
• Holiday circuit CC1 / CC2 / CC3 menu		
Preselection	Preselection (641/651/661)	---
Adjust the time programme	On / Off phases (642-643) (652-653) (662-663)	---
• Switch the heating mode to automatic		AUTO

Optimisation of DHW:

	<i>Line No.</i>	<i>Value</i>
<ul style="list-style-type: none"> • DHW storage tank menu <p style="margin-left: 20px;">Adjust the boost</p>		
Starting value of boost temperature (5020)		16 °C

Optimisation of the cascade:

The cascade may be optimised as required with the parameters of the **Cascade** menu. Refer to the LMS boiler command table instructions for more details.

Maintenance optimisation:

It is possible to generate a maintenance message without harming the boiler. This maintenance message may appear when the 3 following meters have elapsed:

- Time since last maintenance (or commissioning): set parameter 7044 to 12 months
- Operating hours of the burner (parameter 7040)
- Number of start-ups (parameter 7042)

The last 2 parameters depend on the boiler room's hydraulic installation. It is recommended to use at least parameter 7044 for yearly maintenance.

10. LIST OF SPARE PARTS

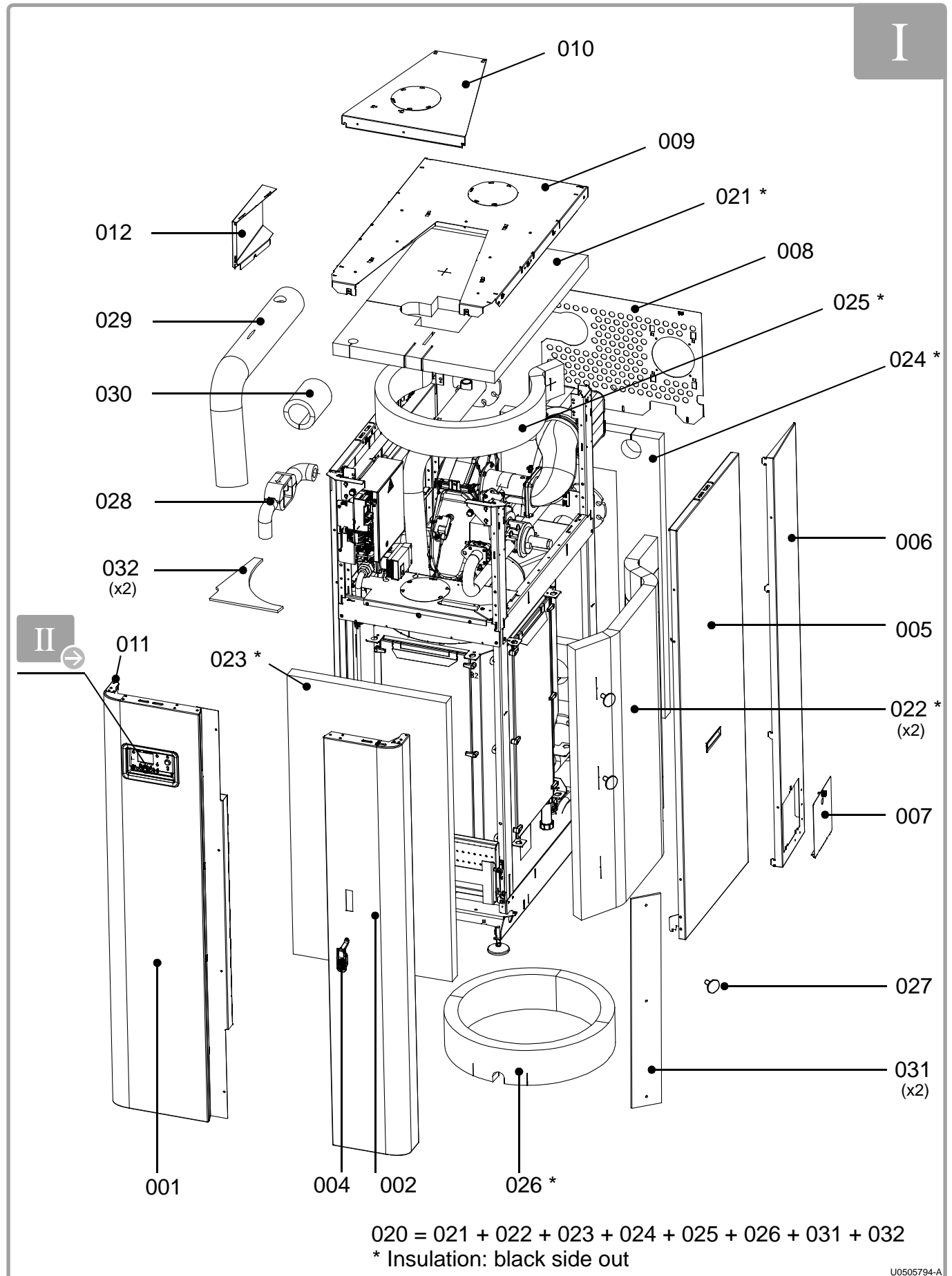

U0505794-A

figure 68 - Cladding / Insulation

Mark	NAME	REF. FOR MODELS			
		120 & 140	180 & 225	275 & 320	390 & 450
Cladding					
001	Front left-hand door	76092	76093	76094	76095
003	Front right-hand door	76088	76089	76090	76091
004	Lock	76024			
005	Side jacket	76096	76097	76098	76099
006	Rear mounting	76100	76101	76102	76103
007	Siphon hatch	76116			
008	Rear closure	76112	76113	76114	76115
009	Roof	76104		76106	76107
010	Opening roof	76108		76110	76111
011	Door pin	72898			
012	Cable exit	76426			
Insulation					
020	Glass wool panels	76117	76118	76119	76120
021	Superior panel insulation	76279	76280	76281	76282
022	Side panel insulation	76283	76284	76285	76286
023	Front panel insulation	76287	76288	76289	76290
024	Back panel insulation	76291	76292	76293	76294
025	Superior boa insulation	76295	76296	76297	76298
026	Inferior boa insulation	76299	76300	76301	76302
027	Insulation support (6 parts)	76125			
028	Insulation of recycling tube, circulation pump and return on flow nozzle	76121		76123	
029	Flow insulation kit	76303	76304	76305	76306
030	Return insulation kit	76307	76308	76309	
031	Front pillars refractory	--			76773
032	Tubesheet refractory	--			76774

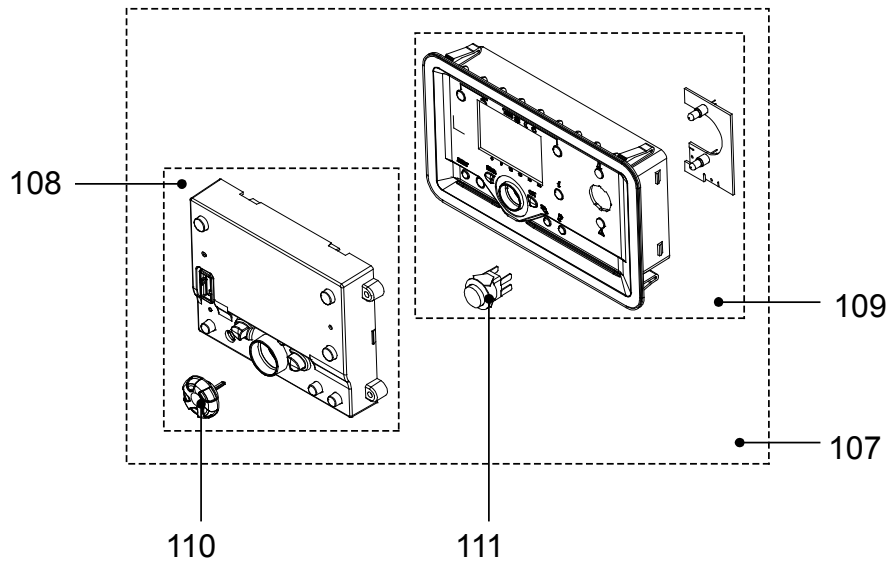
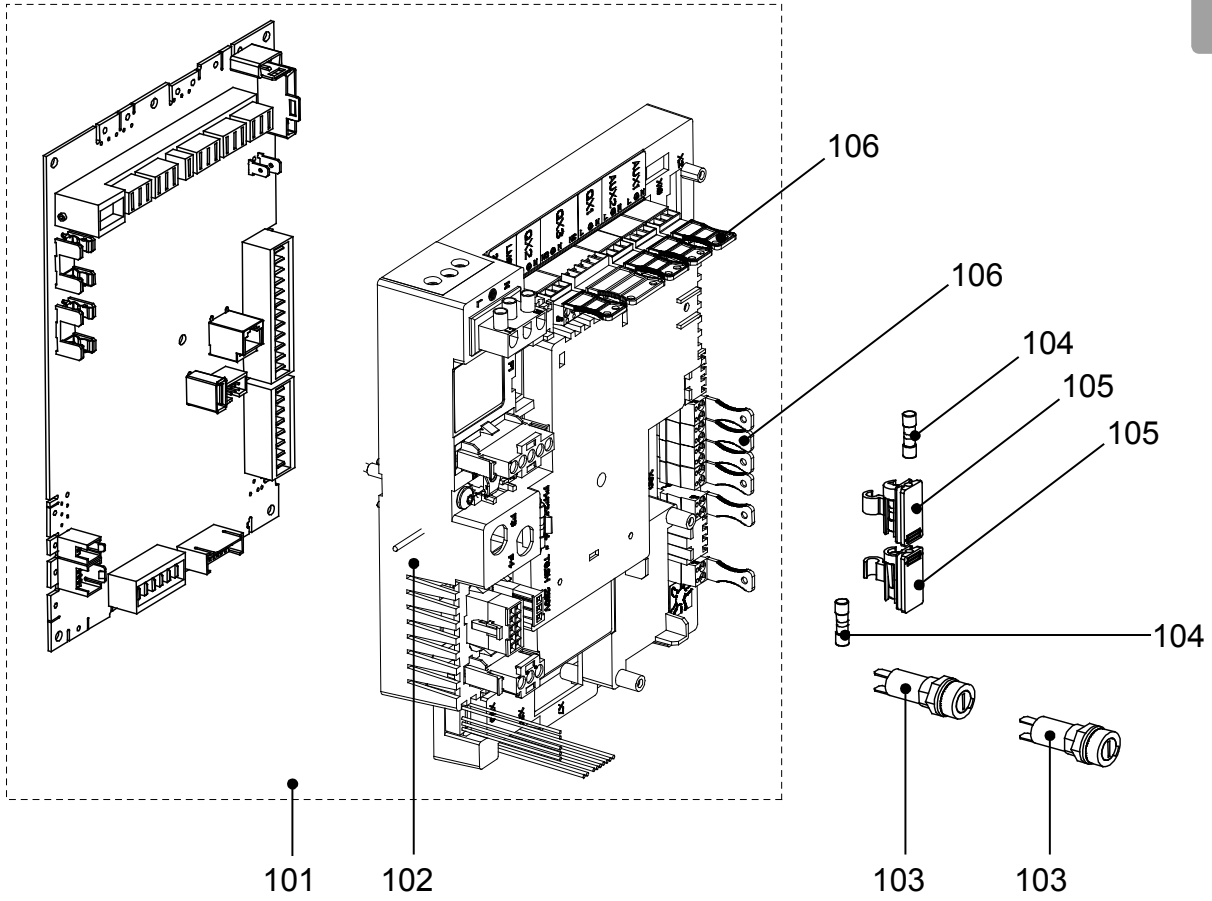

U0505839-# / U0505841-#

figure 69 - Control panel

Mark	NAME	REF. FOR MODELS			
		120 & 140	180 & 225	275 & 320	390 & 450
Control panel					
101	Platform with LMS configured	120 : 76253 140 : 76254	180 : 76255 225 : 76256	275 : 76257 320 : 76258	380 : 76259 450 : 76260
102	Platform without LMS and with wiring	76127			
103	Round fuse holder	76130			
104	Fuse (T 6.3 H - 5x20)	71898			
105	Square fuse holder (with fuse)	76129			
106	Customer connectors to platform	76128			
107	Full display (MMI)	76131			
108	Single display (MMI) with thumbwheel	76132			
109	Plastic part of display (MMI) + LED card + switch + LED webbing	76133			
110	Thumbwheel	76135			
111	Switch	76134			
--	High voltage wiring	76136	76137	76138	
--	Low voltage wiring	76139	76140	76141	
--	LMS / boiler earth wiring	76142			
--	Base / body earth wiring	76143			
--	Cladding / structure earth wiring	76144			
--	Wiring for display power (MMI)	76145			
--	AVS75 power wiring	76146			
--	AVS75 control ribbon cable	76147			
--	Display (MMI) ribbon cable	76148			
--	Circulation pump wiring	76149		76150	
--	Gas valve connector cable	76628	--		



Flow direction in circulation pump

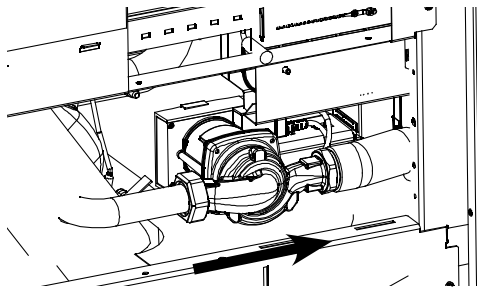

Models 120 to 225

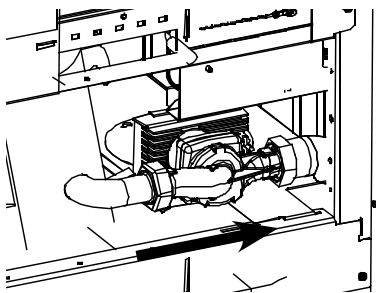

Models 275 to 450

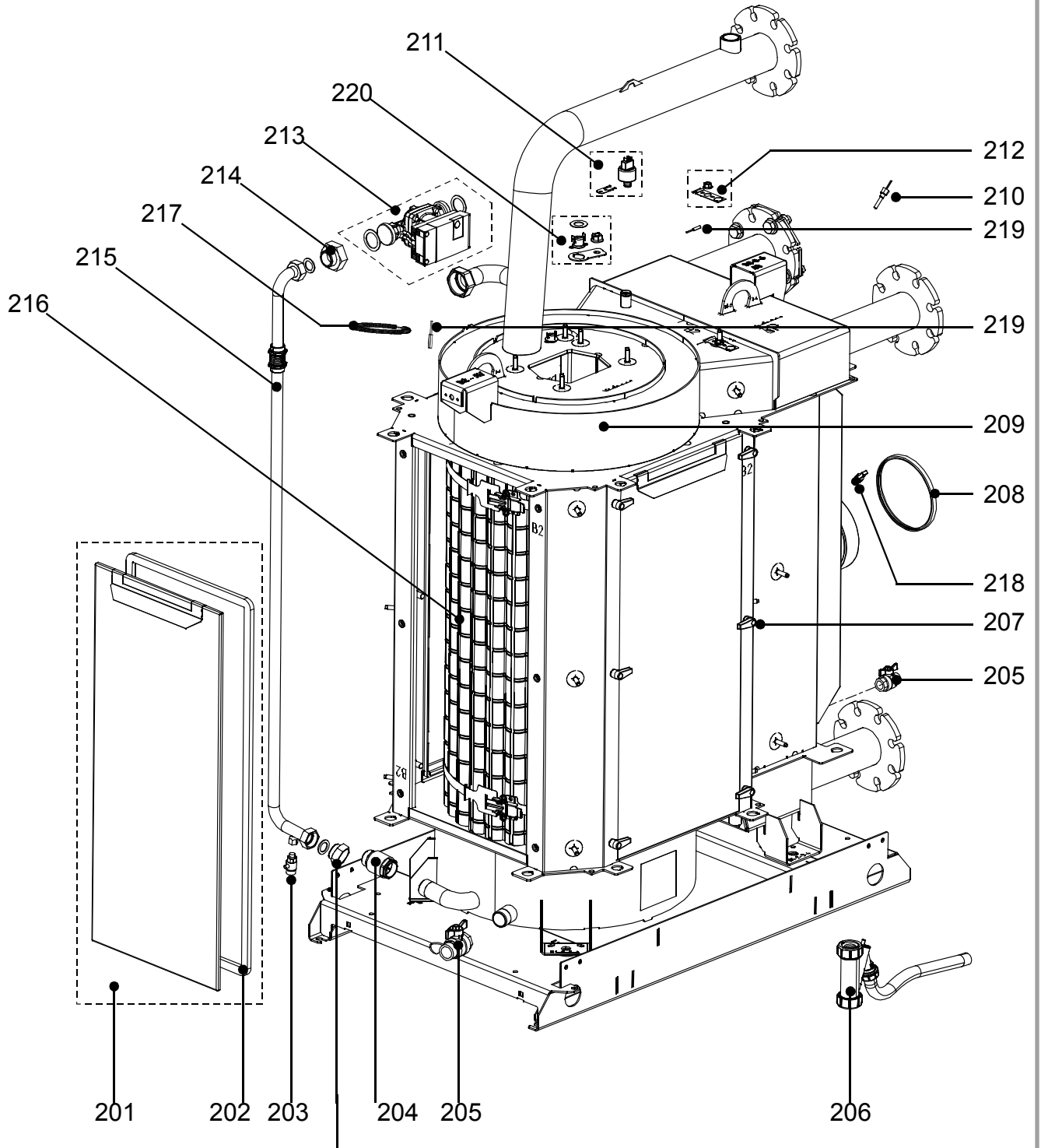

214: Models 275 and 320

U0505837-A

figure 70 - Body

Mark	NAME	REF. FOR MODELS			
		120 & 140	180 & 225	275 & 320	390 & 450
Body					
201	Exchanger door with seal	76015	76016	76017	76018
202	Exchanger door seals (x3)	76019	76020	76021	76022
203	Drain cock	72171			
204	Anti-return valve on recirculation	76008		76009	
205	Drain valve	73947			
206	Condensate siphon	71925			
207	Tightening clamp and attachment screws for exchanger door (x8)	76023			
208	Flue outlet seal	76027		76028	76029
209	Heat exchanger (2 or 3 tappings)	76053	76054	76055	76056
	Heat exchanger (4 tappings)	76057	76058	76059	76060
210	Flue-gas temperature sensor with seal	76014			
211	Pressure sensor with attachment	73946			
212	Support plate for return sensor and safety thermostat with attachment bolt	76025			
213	Circulation pump with seals	76000		76001	
214	Hydraulic reduction with seals	76006		76007	--
215	Recirculation rod with seals	76002	76003	76004	76005
216	Flue-gas baffles with holding spring and strappings	76010	76011	76012	76013
217	Flow sensor attachment kit	76262	76063	76263	
218	Stopper for sample point	76026			
219	Flow / Return sensor	71899			
220	Safety thermostat + dielectric seal + fixture	76158			

IV

Mixer position in venturi
(reference 301)

models 180
& 225

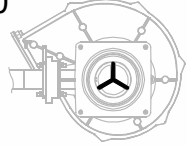

models 390
& 450

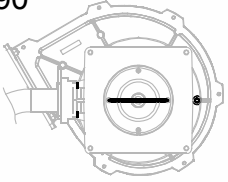
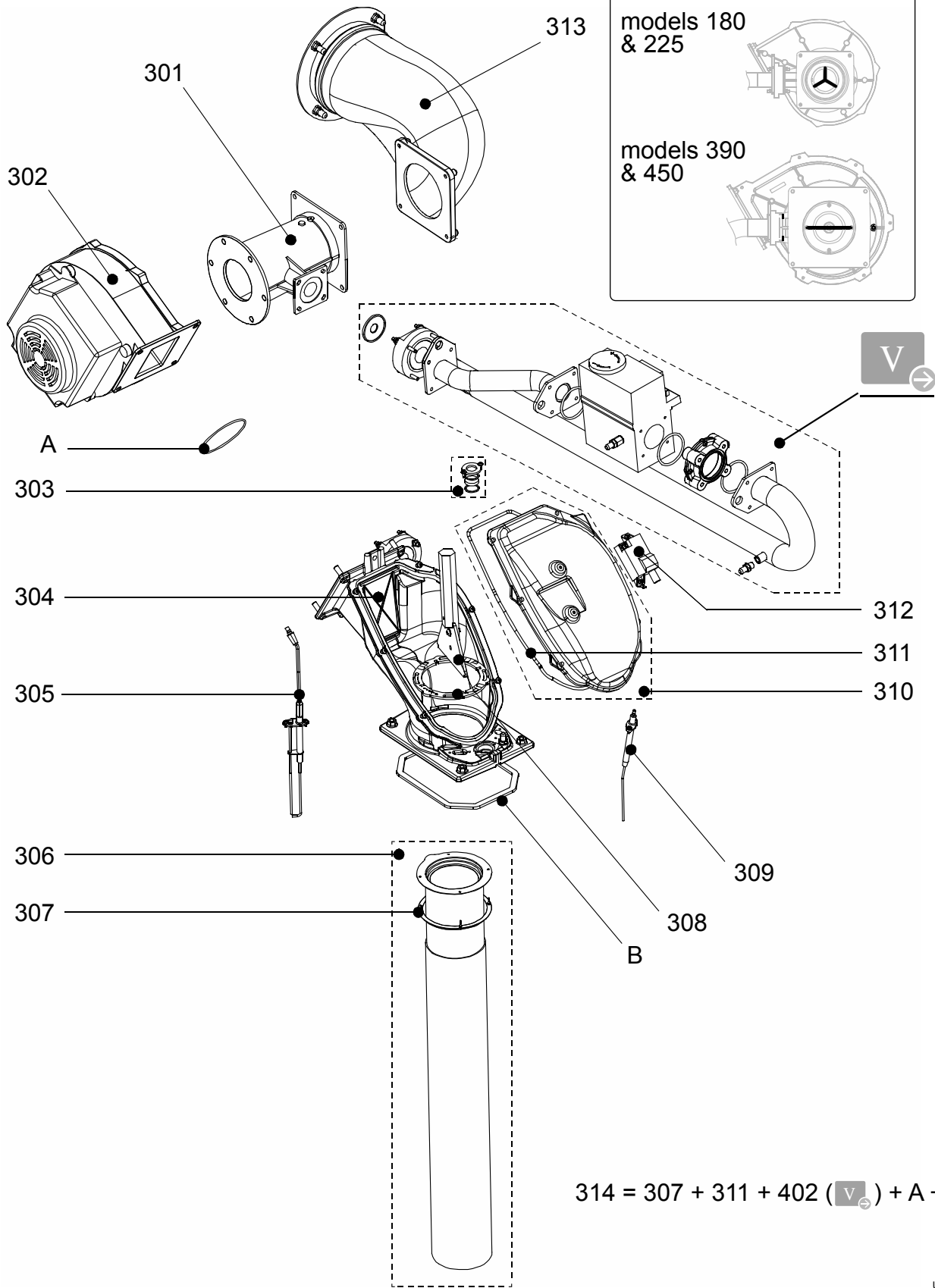
U0505836-#

figure 71 - Burner

Mark	NAME	REF. FOR MODELS			
		120 & 140	180 & 225	275 & 320	390 & 450
Burner					
301	Venturi with mixer	72411	76151	71859	76152
302	Fan	76264	60438	71209	72692
303	Inspection aperture with fastening screws	76048			
304	Spool piece flue-gas anti-return valve	76049	76050	76051	
305	Ignition electrode with fastening screws	76046			
306	Tube with seal	76030	76031	76032	76033
307	Tube seal	76034	76035	76036	
308	Tube assembly (bayonet, mounting tool, mounting tool attachment)	76037	76038	76039	
309	Ionisation electrode with fastening screws	76047			
310	Spool piece cover with seal	76040	76041	76042	
311	Spool piece cover seal	76043	76044	76045	
312	Ignition transformer with tab to screw in and fastening screws	72131			
313	Air inlet duct with seal	76065	76066	76067	76068
314	Burner seal	76061	76062	76064	
--	Micro-compressor to help with ignition	76070			



Models 120 and 140 (G20/G31)

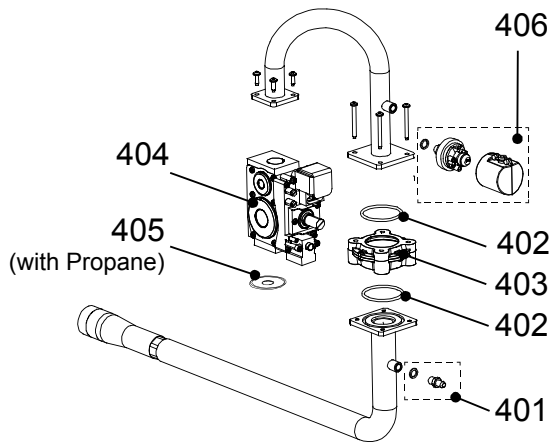

Models
180, 225, 390 and 450 (G20)
180 to 320 (G31)

Models:
275 and 320 (G20)

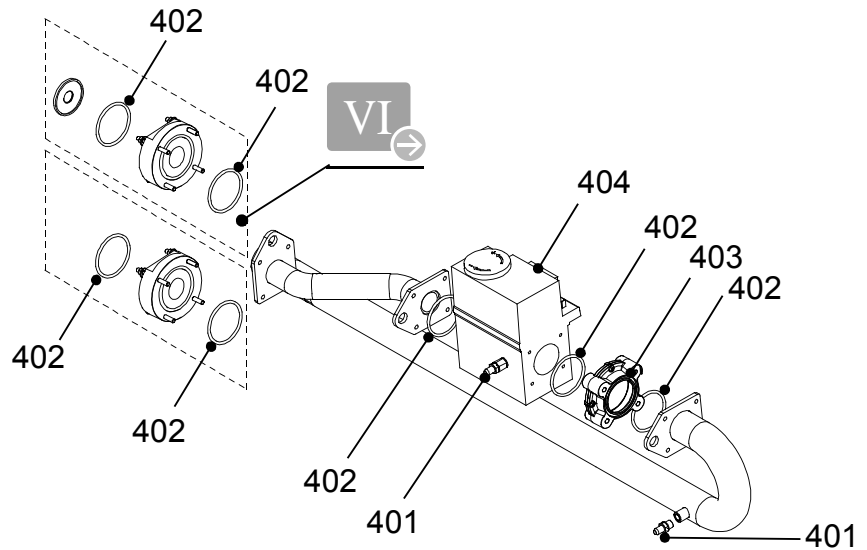

figure 72 - Gas line

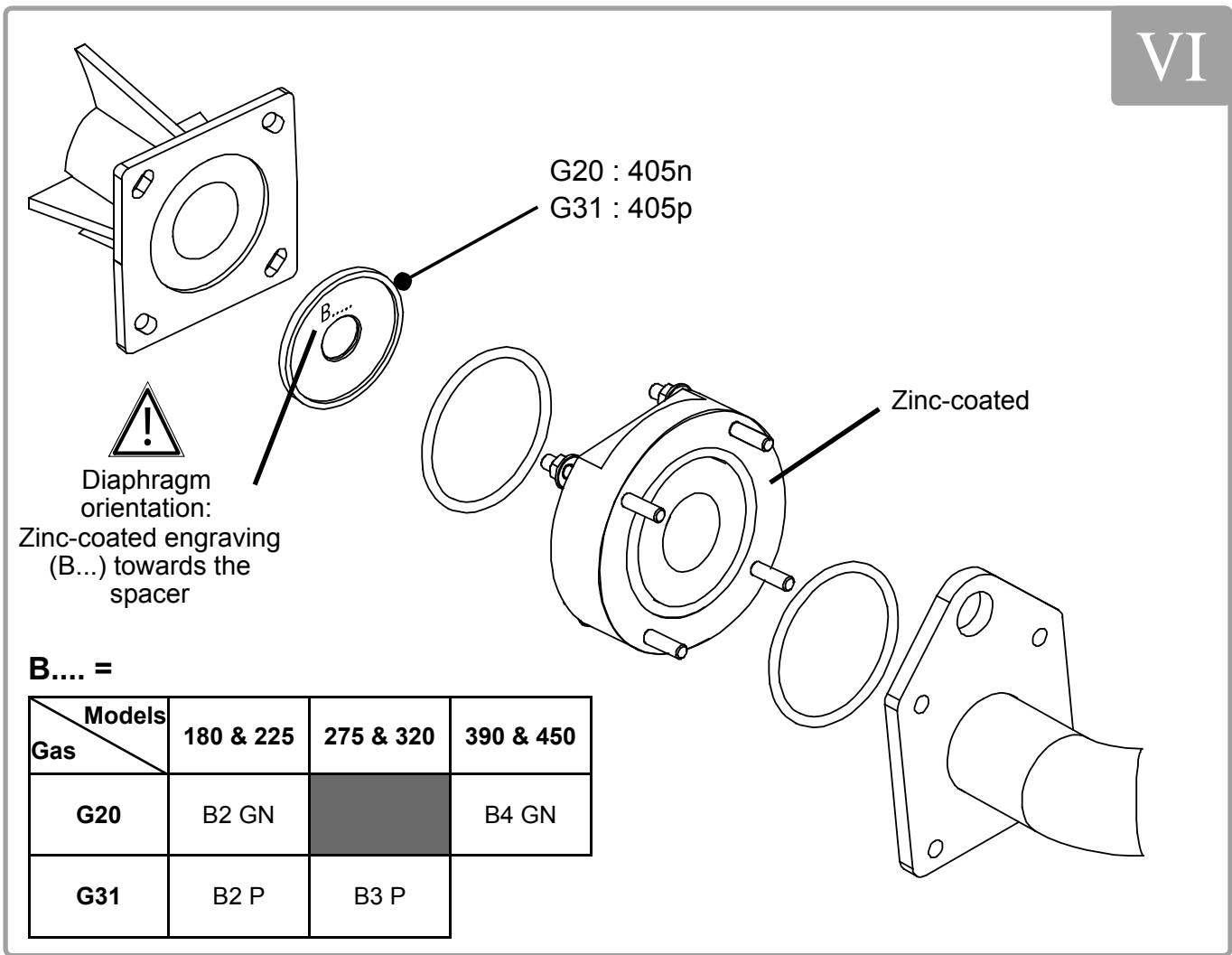

figure 73 - Diaphragm

Mark	NAME	REF. FOR MODELS			
		120 & 140	180 & 225	275 & 320	390 & 450
401	Versilic pipe	76079			
402	Gas line seals	76080	76081		
403	Gas valve filter	71802			
404	Gas valve	76363	76364	76365	76366
405n	Diaphragm G20 (B2 GN : 180/225 ; B4 GN : 390/450)	--	76082	--	76083
405p	Diaphragm G31 (B1 P : 120/140 ; B2 P : 180/225 ; B3 P : 275/320)	76442	76443	76444	--
406	Pre-regulated gas valve pressostat	72409	60439		
--	Gas nozzle pressure connection	76069	76343	76069	76343

VII

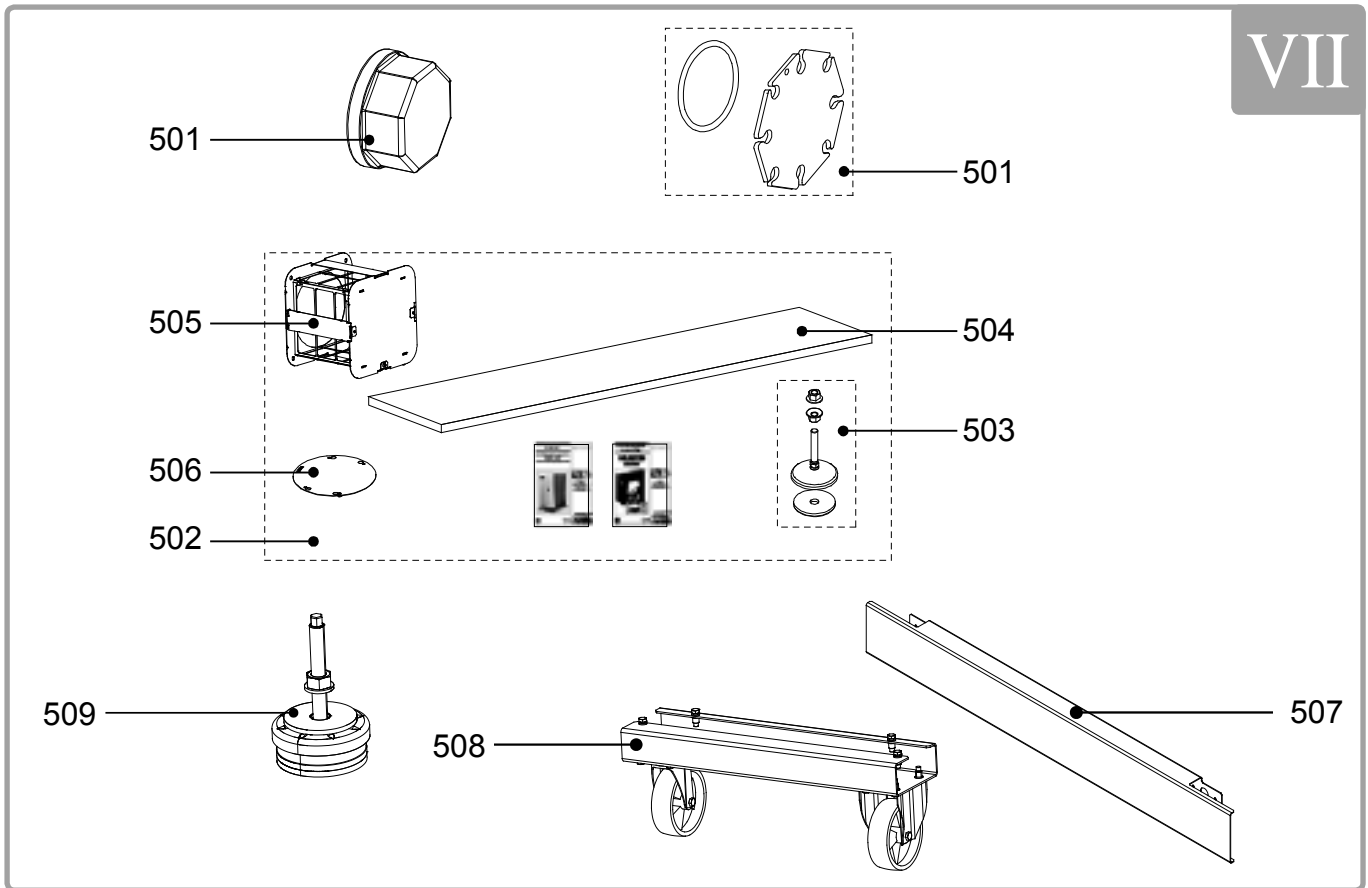

figure 74 - Accessories

Mark	NAME	REF. FOR MODELS			
		120 & 140	180 & 225	275 & 320	380 & 450
Accessories					
501	Cork flange	76154	--		
	Backing flange on third tapping with seal	--	76155	76156	
502	Complete box of accessories (feet, sole, filters, ...)	76268		76269	76270
503	Levelling feet with sole (x4)	76153			
504	Filter matting for air filter	76543			
505	Air filter	76157	76159	76160	
506	Cork passage of slings	76344			
507	Plinths	76165	76166	76167	
508	Rollers	76164	--		
509	Shock absorbing foot	70590			

11. TABLE OF CUSTOMER SETTINGS

Boiler: site:

Serial No.:

Please refer to the parameter modifications in this document!

Note: The "access" column indicates the level of accessibility to the information or programme (E for end user, C for commissioning and S for Specialist). The *Commissioning* level of service integrates the *End User* level. The *Specialist* level integrates the *Commissioning* level.

Line No.	Programme	Access	Control range	Default value	Customer setting
Time of day and date					
1	Hours / minutes	E	00:00 ... 23:59	00 : 00	
2	Day / month	E	01.01 ... 31.12	dd.mm	
3	Year	E	1900 ... 2099	yyyy	
5	Start of summertime	C	01.01 ... 31.12	dd.mm	
6	End of summertime	C	01.01 ... 31.12	dd.mm	
Operator section					
20	Language	E	English Deutsch Français Italiano Nederlands Español	English	
22	Info	C	Temporarily Permanently	Temporarily	
26	Operation lock	C	Off On	Off	
27	Programming lock	C	Off On	Off	
28	Direct adjustment	C	Automatic storage Storage with confirmation	Storage with confirmation	
29	Units	E	°C, bar °F, PSI	°C, bar	
42	Assignment device 1	C	Heating circuit 1 Heating circuits 1 and 2 Heating circuits 1 and 3 All heating circuits	Heating circuit 1	
44	Operation HC2	C	Jointly with HC1 Independently	Jointly with HC1	
46	Operation HC3/P	C	Jointly with HC1 Independently	Jointly with HC1	
70	Software version	C			
Time prog heating circuit 1					
500	Preselection	E	Mo-Su Mo-Fr Sa-Su Mo...Su	Mo-Su	
501	First period start time	E	00:00 ... 24:00	06:00	
502	First period stop time	E	00:00 ... 24:00	22:00	
503	Second period start time	E	00:00 ... 24:00	24:00	
504	Second period stop time	E	00:00 ... 24:00	24:00	
505	Second period start time	E	00:00 ... 24:00	24:00	
506	Second period stop time	E	00:00 ... 24:00	24:00	
516	Default values	E	No Yes	No	
Time prog heating circuit 2					
520	Preselection	E	Mo-Su Mo-Fr Sa-Su Mo...Su	Mo-Su	
521	First period start time	E	00:00 ... 24:00	06:00	
522	First period stop time	E	00:00 ... 24:00	22:00	
523	Second period start time	E	00:00 ... 24:00	24:00	
524	Second period stop time	E	00:00 ... 24:00	24:00	
525	Second period start time	E	00:00 ... 24:00	24:00	
526	Second period stop time	E	00:00 ... 24:00	24:00	
536	Default values	E	No Yes	No	

Line No.	Programme	Access	Control range	Default value	Customer setting
Time prog heating circuit 3					
540	Preselection	E	Mo-Su Mo-Fr Sa-Su Mo...Su	Mo-Su	
541	First period start time	E	00:00 ... 24:00	06:00	
542	First period stop time	E	00:00 ... 24:00	22:00	
543	Second period start time	E	00:00 ... 24:00	24:00	
544	Second period stop time	E	00:00 ... 24:00	24:00	
545	Second period start time	E	00:00 ... 24:00	24:00	
546	Second period stop time	E	00:00 ... 24:00	24:00	
556	Default values	E	No Yes	No	
Time program 4 / DHW					
560	Preselection	E	Mo-Su Mo-Fr Sa-Su Mo...Su	Mo-Su	
561	First period start time	E	00:00 ... 24:00	06:00	
562	First period stop time	E	00:00 ... 24:00	22:00	
563	Second period start time	E	00:00 ... 24:00	24:00	
564	Second period stop time	E	00:00 ... 24:00	24:00	
565	Second period start time	E	00:00 ... 24:00	24:00	
566	Second period stop time	E	00:00 ... 24:00	24:00	
576	Default values	E	No Yes	No	
Time program 5					
600	Preselection	E	Mo-Su Mo-Fr Sa-Su Mo...Su	Mo-Su	
601	First period start time	E	00:00 ... 24:00	06:00	
602	First period stop time	E	00:00 ... 24:00	22:00	
603	Second period start time	E	00:00 ... 24:00	24:00	
604	Second period stop time	E	00:00 ... 24:00	24:00	
605	Second period start time	E	00:00 ... 24:00	24:00	
606	Second period stop time	E	00:00 ... 24:00	24:00	
616	Default values	E	No Yes	No	
Holidays heating circuit 1					
641	Preselection	E	Period 1 ... Period 8	Period 1	
642	Begin (dd.mm)	E	01.01 ... 31.12	01.01	
643	End (dd.mm)	E	01.01 ... 31.12	01.01	
648	Operating level	E	Frost protection Reduced	Frost protection	
Holidays heating circuit 2					
651	Preselection	E	Period 1 ... Period 8	Period 1	
652	Begin (dd.mm)	E	01.01 ... 31.12	01.01	
653	End (dd.mm)	E	01.01 ... 31.12	01.01	
658	Operating level	E	Frost protection Reduced	Frost protection	
Holidays heating circuit 3					
661	Preselection	E	Period 1 ... Period 8	Period 1	
662	Begin (dd.mm)	E	01.01 ... 31.12	01.01	
663	End (dd.mm)	E	01.01 ... 31.12	01.01	
668	Operating level	E	Frost protection Reduced	Frost protection	
Heating circuit 1					
710	Comfort setpoint	E	4 ... 35 °C	20 °C	
712	Reduced setpoint	E	4 ... 35 °C	18 °C	
714	Frost protection setpoint	E	4 ... 35 °C	10 °C	
716	Comfort setpoint max	S	4 ... 35 °C	35 °C	
720	Heating curve slope	E	0.10 ... 4.00	1,5	
721	Heating curve displacement	S	-4,5 ... 4,5 °C	0 °C	

Line No.	Programme	Access	Control range	Default value	Customer setting
726	Heating curve adaptation	S	Off On	Off	
730	Summer/winter heating limit	E	8 ... 30 °C	19 °C	
732	24-hour heating limit	S	-10 ... 10 °C	-3 °C	
740	Flow temp setpoint min	C	8 ... 95 °C	8 °C	
741	Flow temp setpoint max	C	8 ... 95 °C	80 °C	
742	Flow temp setpoint room stat	S	8 ... 95 °C	65 °C	
746	Delay heat request	C	0 ... 600 s	0 s	
750	Room influence	S	1 ... 100 %	20 %	
760	Room temp limitation	S	0,5 ... 4 °C	1 °C	
770	Boost heating	S	0 ... 20 °C	3 °C	
780	Quick setback	S	Off Down to reduced setpoint Down to frost prot setpoint	Off	
790	Optimum start control max	S	00:00 ... 06:00	00:00	
791	Optimum stop control max	S	00:00 ... 06:00	00:00	
800	Reduced setp increase start	S	-30 ... 10 °C	-5 °C	
801	Reduced setp increase end	S	-30 ... 10 °C	-15 °C	
809	Continuous pump operation	S	No Yes	No	
820	Overtemp prot pump circuit	S	Off On	On	
830	Mixing valve boost	S	0 ... 50 °C	3 °C	
832	Actuator type	S	2-position 3-position	3-position	
833	TOR Switching differential	S	0 ... 20 °C	2 °C	
834	Actuator running time	S	30 ... 873 s	120 s	
850	Floor curing function	C	Off Functional heating Curing heating Functional/curing heating Curing/functional heating Manually	Off	
851	Floor curing setp manually	C	0 ... 95 °C	25 °C	
855	Floor curing setp current	E	0 ... 95 °C	0 °C	
856	Floor curing day current	E	0 ... 32	0	
861	Excess heat draw	S	Off Heating mode Always	Always	
870	With buffer	S	No Yes	No	
872	With prim contr/system pump	S	No Yes	No	
880	Pump speed reduction	S	Operating level Caractéristic	Caractéristic	
882	Pump speed min	S	0 ... 100 %	50 %	
883	Pump speed max	S	0 ... 100 %	100 %	
888	Curve readj at 50% speed	S	0 ... 100 %	33 %	
889	Filter time const speed ctrl	S	0 ... 20 min	5 min	
890	Flow setp readj speed ctrl	S	No Yes	Yes	
898	Operating level changeover	S	Frost protection Reduced Comfort	Reduced	
900	Optg mode changeover	S	None Protection Reduced Comfort Automatic	Protection	
Heating circuit 2					
1010	Comfort setpoint	E	4 ... 35 °C	20 °C	
1012	Reduced setpoint	E	4 ... 35 °C	18 °C	
1014	Frost protection setpoint	E	4 ... 35 °C	10 °C	
1016	Comfort setpoint max	S	4 ... 35 °C	35 °C	
1020	Heating curve slope	E	0.10 ... 4.00	1,5	
1021	Heating curve displacement	S	-4,5 ... 4,5 °C	0 °C	
1026	Heating curve adaptation	S	Off On	Off	

Line No.	Programme	Access	Control range	Default value	Customer setting
1030	Summer/winter heating limit	E	8 ... 30 °C	19 °C	
1032	24-hour heating limit	S	-10 ... 10 °C	-3 °C	
1040	Flow temp setpoint min	C	8 ... 95 °C	8 °C	
1041	Flow temp setpoint max	C	8 ... 95 °C	80 °C	
1042	Flow temp setpoint room stat	S	8 ... 95 °C	65 °C	
1046	Delay heat request	C	0 ... 600 s	0 s	
1050	Room influence	S	1 ... 100 %	20 %	
1060	Room temp limitation	S	0,5 ... 4 °C	1 °C	
1070	Boost heating	S	0 ... 20 °C	3 °C	
1080	Quick setback	S	Off Down to reduced setpoint Down to frost prot setpoint	Off	
1090	Optimum start control max	S	00:00 ... 06:00	00:00	
1091	Optimum stop control max	S	00:00 ... 06:00	00:00	
1100	Reduced setp increase start	S	-30 ... 10 °C	-5 °C	
1101	Reduced setp increase end	S	-30 ... 10 °C	-15 °C	
1109	Continuous pump operation	S	No Yes	No	
1120	Overtemp prot pump circuit	S	Off On	On	
1130	Mixing valve boost	S	0 ... 50 °C	3 °C	
1132	Actuator type	S	2-position 3-position	3-position	
1133	TOR Switching differential	S	0 ... 20 °C	2 °C	
1134	Actuator running time	S	30 ... 873 s	120 s	
1150	Floor curing function	C	Off Functional heating Curing heating Functional/curing heating Curing/functional heating Manually	Off	
1151	Floor curing setp manually	C	0 ... 95 °C	25 °C	
1155	Floor curing setp current	E	0 ... 95 °C	0 °C	
1156	Floor curing day current	E	0 ... 32	0	
1161	Excess heat draw	S	Off Heating mode Always	Always	
1170	With buffer	S	No Yes	No	
1172	With prim contr/system pump	S	No Yes	No	
1180	Pump speed reduction	S	Operating level Caractéristic	Characteristic	
1182	Pump speed min	S	0 ... 100 %	50 %	
1183	Pump speed max	S	0 ... 100 %	100 %	
1188	Curve readj at 50% speed	S	0 ... 100 %	33 %	
1189	Filter time const speed ctrl	S	0 ... 20 min	5 min	
1190	Flow setp readj speed ctrl	S	No Yes	Yes	
1198	Operating level changeover	S	Frost protection Reduced Comfort	Reduced	
1200	Optg mode changeover	S	None Protection Reduced Comfort Automatic	Protection	
Heating circuit 3					
1310	Comfort setpoint	E	4 ... 35 °C	20 °C	
1312	Reduced setpoint	E	4 ... 35 °C	18 °C	
1314	Frost protection setpoint	E	4 ... 35 °C	10 °C	
1316	Comfort setpoint max	S	4 ... 35 °C	35 °C	
1320	Heating curve slope	E	0.10 ... 4.00	1,5	
1321	Heating curve displacement	S	-4,5 ... 4,5 °C	0 °C	
1326	Heating curve adaptation	S	Off On	Off	
1330	Summer/winter heating limit	E	8 ... 30 °C	19 °C	

Line No.	Programme	Access	Control range	Default value	Customer setting
1332	24-hour heating limit	S	-10 ... 10 °C	-3 °C	
1340	Flow temp setpoint min	C	8 ... 95 °C	8 °C	
1341	Flow temp setpoint max	C	8 ... 95 °C	80 °C	
1342	Flow temp setpoint room stat	S	8 ... 95 °C	65 °C	
1346	Delay heat request	C	0 ... 600 s	0 s	
1350	Room influence	S	1 ... 100 %	20 %	
1360	Room temp limitation	S	0,5 ... 4 °C	1 °C	
1370	Boost heating	S	0 ... 20 °C	3 °C	
1380	Quick setback	S	Off Down to reduced setpoint Down to frost prot setpoint	Off	
1390	Optimum start control max	S	00:00 ... 06:00	00:00	
1391	Optimum stop control max	S	00:00 ... 06:00	00:00	
1400	Reduced setp increase start	S	-30 ... 10 °C	-5 °C	
1401	Reduced setp increase end	S	-30 ... 10 °C	-15 °C	
1409	Continuous pump operation	S	No Yes	No	
1420	Overtemp prot pump circuit	S	Off On	On	
1430	Mixing valve boost	S	0 ... 50 °C	3 °C	
1432	Actuator type	S	2-position 3-position	3-position	
1433	TOR Switching differential	S	0 ... 20 °C	2 °C	
1434	Actuator running time	S	30 ... 873 s	120 s	
1450	Floor curing function	C	Off Functional heating Curing heating Functional/curing heating Curing/functional heating Manually	Off	
1451	Floor curing setp manually	C	0 ... 95 °C	25 °C	
1455	Floor curing setp current	E	0 ... 95 °C	0 °C	
1456	Floor curing day current	E	0 ... 32	0	
1461	Excess heat draw	S	Off Heating mode Always	Always	
1470	With buffer	S	No Yes	No	
1472	With prim contr/system pump	S	No Yes	No	
1480	Pump speed reduction	S	Operating level Caractéristic	Characteristic	
1482	Pump speed min	S	0 ... 100 %	50 %	
1483	Pump speed max	S	0 ... 100 %	100 %	
1488	Curve readj at 50% speed	S	0 ... 100 %	33 %	
1489	Filter time const speed ctrl	S	0 ... 20 min	5 min	
1490	Flow setp readj speed ctrl	S	No Yes	Yes	
1498	Operating level changeover	S	Frost protection Reduced Comfort	Reduced	
1500	Optg mode changeover	S	None Protection Reduced Comfort Automatic	Protection	
Domestic hot water					
1610	Nominal setpoint	E	8 ... 80 °C	50 °C	
1612	Reduced setpoint	S	8 ... 80 °C	40 °C	
1614	Nominal setpoint max	S	8 ... 80 °C	65 °C	
1620	Release	C	24h/day Time programs HCs Time program 4/DHW	24h/day	
1630	Charging priority	C	Absolute Shifting None MC shifting, PC absolute	MC shifting, PC absolute	
1640	Legionella function	S	Off Périodically Fixed weekday	Off	
1641	Legionella funct periodically	S	1 ... 7	3	

Line No.	Programme	Access	Control range	Default value	Customer setting
1642	Legionella funct weekday	S	Monday Tuesday Wednesday Thursday Friday Saturday Sunday	Monday	
1644	Legionella funct time	S	00:00 ... 23:50 h:m	05:00	
1645	Legionella funct setpoint	S	55 ... 95 °C	55 °C	
1646	Legionella funct duration	S	10 ... 360 min	30 min	
1647	Legionella funct circ pump	S	Off On	On	
1660	Circulating pump release	S	Time program 3 / HCP DHW release Time program 4 / DHW Time program 5	DHW release	
1661	Circulating pump cycling	S	Off On	On	
1663	Circulation setpoint	S	8 ... 80 °C	45 °C	
1680	Optg mode changeover	S	None Off On	Off	
Consumer circuit 1					
1859	Flow temp setp cons request	C	8 ... 120 °C	60 °C	
1875	Excess heat draw	S	Off On	On	
1878	With buffer	S	No Yes	No	
1880	With prim contr/system pump	S	No Yes	No	
Consumer circuit 2					
1909	Flow temp setp cons request	C	8 ... 120 °C	60 °C	
1925	Excess heat draw	S	Off On	On	
1928	With buffer	S	No Yes	No	
1930	With prim contr/system pump	S	No Yes	No	
Consumer circuit 3					
1959	Flow temp setp cons request	C	8 ... 120 °C	70 °C	
1975	Excess heat draw	S	Off On	On	
1978	With buffer	S	No Yes	No	
1980	With prim contr/system pump	S	No Yes	No	
Swimming pool					
2055	Setpoint solar heating	S	8 ... 80 °C	26 °C	
2056	Setpoint source heating	S	8 ... 80 °C	22 °C	
2065	Charging priority solar	S	Priority 1 ... Priority 3	Priority 2	
2080	With solar integration	S	No Yes	Yes	
Boiler					
2203	Release below outside temp	S	-50 ... 50 °C	0 °C	
2208	Full charging buffer	S	Off On	Off	
2210	Setpoint min	S	8 ... 95 °C	8 °C	
2212	Setpoint max	S	8 ... 95 °C	85 °C	
2214	Setpoint manual control	E	(setpoint min) ... (setpoint max)	70 °C	
2217	Setpoint frost protection	S	-20 ... 20 °C	8 °C	
2243	Burner off time min	S	0 ... 20 min	5 min	
2245	SD burner off time	S	0 ... 80 °C	10 °C	
2250	Pump overrun time	S	0 ... 240 min	5 min	
2253	Pump overr time after DHW	S	0 ... 20 min	1 min	
2270	Return setpoint min	S	8 ... 95 °C	8 °C	
2330	Output nominal	S	0 ... 2000 kW	Depending on boiler	
2331	Output basic stage	S	0 ... 2000 kW	Depending on boiler	
2441	Fan speed heating max	S	0 ... 10000 tr/min	Depending on boiler	
2442	Fan speed full charging max	S	0 ... 10000 tr/min	Depending on boiler	
2444	Fan speed DHW max	S	0 ... 10000 tr/min	Depending on boiler	

Line No.	Programme	Access	Control range	Default value	Customer setting
2454	Switching diff on HCs	S	0 ... 20 °C	3 °C	
2455	Switching diff off min HCs	S	0 ... 20 °C	3 °C	
2456	Switching diff off max HCs	S	0 ... 20 °C	6 °C	
2457	Settling time HCs	S	0 ... 240 min	20 min	
2460	Switching diff on DHW	S	0 ... 20 °C	3 °C	
2461	Switching diff off min DHW	S	0 ... 20 °C	3 °C	
2462	Switching diff off max DHW	S	0 ... 20 °C	6 °C	
2463	Settling time DHW	S	0 ... 240 min	20 min	
2470	Delay heat req special op	C	0 ... 600 s	0 s	
Cascade					
3510	Lead strategy	S	Late on, early off Late on, late off Early on, late off	Early on, late off	
3511	Output band min	S	0 ... 100 %	30 %	
3512	Output band max	S	0 ... 100 %	90 %	
3530	Release integral source seq	S	50 ... 300 °Cmin	50 °Cmin	
3531	Reset integral source seq	S	20 ... 100 °Cmin	20 °Cmin	
3532	Restart lock	S	0 ... 1800 s	300 s	
3533	Switch on delay	S	0 ... 120 min	5 min	
3534	Forced time basic stage	S	0 ... 1200 s	60 s	
3540	Auto source seq ch'over	S	10 ... 990 h	500 h	
3541	Auto source seq exclusion	S	none first last first and last	none	
3544	Leading source	S	source 1 ... source 16	source 1	
3560	Return setpoint min	S	8 ... 95 °C	8 °C	
3562	Return influence consumers	S	Off On	On	
DHW storage tank					
5020	Flow setpoint boost	S	0 ... 30 °C	16 °C	
5021	Transfer boost	S	0 ... 30 °C	8 °C	
5022	Type of charging	S	Recharging Full charging Full charging legio Full charg 1st time day Full charg 1st time legio	Full charging	
5050	Charging temp max	S	8 ... 95 °C	80 °C	
5055	Recooling temp	S	8 ... 95 °C	80 °C	
5056	Recooling heat gen/HCs	S	Off On	Off	
5057	Recooling collector	S	Off Summer Always	Off	
5060	El imm heater optg mode	S	Substitute Summer Always	Substitute	
5061	El immersion heater release	S	24h/day DHW release Time program 4/DHW	DHW release	
5062	El immersion heater control	S	External thermostat DHW sensor	DHW sensor	
5085	Excess heat draw	S	Off On	On	
5090	With buffer	S	No Yes	No	
5092	With prim contr/system pump	S	No Yes	No	
5093	With solar integration	S	No Yes	Yes	
5101	Pump speed min	S	0 ... 100 %	40 %	
5102	Pump speed max	S	0 ... 100 %	100 %	
Configuration					
5710	Heating circuit 1	C	Off On	Off	
5711	Cooling circuit 1	C	Off 4-pipe system cooling	Off	
5715	Heating circuit 2	C	Off On	Off	

Line No.	Programme	Access	Control range	Default value	Customer setting
5721	Heating circuit 3	C	Off On	Off	
5730	DHW sensor	C	DHW sensor B3 Thermostat DHW outlet sensor B38	DHW sensor B3	
5731	DHW controlling element	C	No charging request Charging pump Diverting valve	Charging pump	
5732	Pump off change div valve	C	0 ... 10 s	0 s	
5733	Delay pump off	C	0 ... 10 s	0 s	
5734	Basic position DHW div valve	S	Last request Heating circuit DHW	Last request	
5736	DHW separate circuit	C	Off On	Off	
5737	Optg action DHW div valve	S	Position on DHW Position on heating circuit	Position on DHW	
5738	Midposition DHW div valve	S	Off On	Off	
5774	Ctrl boiler pump/DHW valve	C	All requests Request HC1/DHW only	All requests	
5840	Solar controlling element	C	Charging pump Diverting valve	Charging pump	
5841	External solar exchanger	C	Jointly DHW storage tank Buffer storage tank	Jointly	
5870	Combi storage tank	C	No Yes	No	
5890	Relay output QX1	C	None Cons circuit pump VK1 Q15 Boiler pump Q1 Alarm output K10 Heat circuit pump HC3 Q20 Cons circuit pump VK2 Q18 Cascade pump Q25 Heat circuit pump HC1 Q2 Heat circuit pump HC2 Q6 DHW ctrl elem Q3 Status information K36	Alarm output K10	
5891	Relay output QX2	C	<i>Ditto line 5890</i>	None	
5892	Relay output QX3	C	<i>Ditto line 5890</i>	Boiler pump Q1	
5931	Sensor input BX2	C	None Common flow sensor B10 Cascade return sensor B70	None	
5932	Sensor input BX3	C	<i>Ditto line 5931</i>	None	
5950	Function input H1	C	None Optg mode change HCs+DHW Optg mode changeover HCs Optg mode changeover HC1 Optg mode changeover HC2 Optg mode changeover HC3 Heat generation lock Error/alarm message Consumer request VK1 Consumer request VK2 Excess heat discharge Consumer request VK1 10V Consumer request VK2 10V Pressure measurement 10V	None	
5951	Contact type H1	C	NC NO	NO	
5953	Voltage value 1 H1 (U1)	C	0 ... 10 V	0 V	
5954	Function value 1 H1 (F1)	C	-1000 ... 5000	0	
5955	Voltage value 2 H1 (U2)	C	0 ... 10 V	10 V	
5956	Function value 2 H1 (F2)	C	-1000 ... 5000	1000	
5977	Function input H5	C	<i>Ditto line 5950</i>	None	
5978	Contact type H5	C	<i>Ditto line 5951</i>	NC	
6020	Function extension module 1	C	None Multifunctional Heat circuit 1 Heat circuit 2 Heat circuit 3 Return temp controller Primary contr/system pump	None	

Line No.	Programme	Access	Control range	Default value	Customer setting
6021	Function extension module 2	C	<i>Ditto line 6020</i>	None	
6022	Function extension module 3	C	<i>Ditto line 6020</i>	None	
6024	Funct input EX21 module 1	C	None Limit thermostat HC	None	
6026	Funct input EX21 module 2	C	None Limit thermostat HC	None	
6028	Funct input EX21 module 3	C	None Limit thermostat HC	None	
6030	Relay output QX21 module 1	C	<i>Ditto line 5890</i>	None	
6031	Relay output QX22 module 1	C	<i>Ditto line 5890</i>	None	
6032	Relay output QX23 module 1	C	<i>Ditto line 5890</i>	None	
6033	Relay output QX21 module 2	C	<i>Ditto line 5890</i>	None	
6034	Relay output QX22 module 2	C	<i>Ditto line 5890</i>	None	
6035	Relay output QX23 module 2	C	<i>Ditto line 5890</i>	None	
6036	Relay output QX21 module 3	C	<i>Ditto line 5890</i>	None	
6037	Relay output QX22 module 3	C	<i>Ditto line 5890</i>	None	
6038	Relay output QX23 module 3	C	<i>Ditto line 5890</i>	None	
6040	Sensor input BX21 module 1	C	<i>Ditto line 5931</i>	None	
6041	Sensor input BX22 module 1	C	<i>Ditto line 5931</i>	None	
6042	Sensor input BX21 module 2	C	<i>Ditto line 5931</i>	None	
6043	Sensor input BX22 module 2	C	<i>Ditto line 5931</i>	None	
6044	Sensor input BX21 module 3	C	<i>Ditto line 5931</i>	None	
6045	Sensor input BX22 module 3	C	<i>Ditto line 5931</i>	None	
6046	Function input H2 module 1	C	<i>Ditto line 5950</i>	None	
6047	Contact type H2 module 1	C	<i>Ditto line 5951</i>	NO	
6049	Voltage value 1 H2 module 1(U1)	C	0 ... 10 V	0 V	
6050	Function value 1 H2 module 1 (F1)	C	-1000 ... 5000	0	
6051	Voltage value 2 H2 module 1 (U2)	C	0 ... 10 V	0 V	
6052	Function value 2 H2 module 1 (F2)	C	-1000 ... 5000	0	
6054	Function input H2 module 2	C	<i>Ditto line 5950</i>	None	
6055	Contact type H2 module 2	C	<i>Ditto line 5951</i>	NO	
6057	Voltage value 1 H2 module 2(U1)	C	0 ... 10 V	0 V	
6058	Function value 1 H2 module 2 (F1)	C	-1000 ... 5000	0	
6059	Voltage value 2 H2 module 2 (U2)	C	0 ... 10 V	0 V	
6060	Function value 2 H2 module 2 (F2)	C	-1000 ... 5000	0	
6062	Function input H2 module 3	C	<i>Ditto line 5950</i>	None	
6063	Contact type H2 module 3	C	<i>Ditto line 5951</i>	NO	
6065	Voltage value 1 H2 module 3(U1)	C	0 ... 10 V	0 V	
6066	Function value 1 H2 module 3 (F1)	C	-1000 ... 5000	0	
6067	Voltage value 2 H2 module 3 (U2)	C	0 ... 10 V	0 V	
6068	Function value 2 H2 module 3 (F2)	C	-1000 ... 5000	0	
6097	Sensor type collector	S	NTC Pt 1000	NTC	
6098	Readjustm collector sensor	S	-20 ... 20 °C	0 °C	
6100	Readjustm outside sensor	S	-3 ... 3 °C	0 °C	
6110	Time constant building	S	0 ... 50 h	15 h	
6116	Const tmpls compens consig.	S	0 ... 14 min	1 min	
6117	Compens centr T° consigne	S	1 ... 100 °C	3 °C	
6120	Frost protection plant	S	Off On	Off	
6127	Pump/valve kick duration	S	0 ... 51 s	30 s	
6200	Save sensors	C	No Yes	No	
6205	Reset to default parameter	S	No Yes	No	

Line No.	Programme	Access	Control range	Default value	Customer setting
6212	Check no. heat source 1	C	11 : no pump 12 : with boiler pump 13 : with recycling pump 14 : with boiler and recycling pumps	14 : with boiler and recycling pumps	
6215	Check no. storage tank	C	0 : tank 4 : DHW with pump	0 : tank	
6217	Check no. heating circuits	C	1 ... 30303	0	
6220	Software version	S			
6230	Info 1 OEM	S	1 : 120kW 2 : 140kW 3 : 180kW 4 : 225kW 5 : 275kW 6 : 320kW		
6231	Info 2 OEM	S	Version configuration		
6234	Boiler type	S	1 : VARMAX 2 : CONDENSINOX 3 : ...	1 : VARMAX	
LPB system					
6600	Device address	C	0 ... 16	1	
6601	Segment address	S	0 ... 14	0	
6604	Bus power supply function	S	Off Automatically	Automatically	
6605	Bus power supply state	S	Off On	On	
6620	Action changeover functions	S	Segment System	System	
6621	Summer changeover	S	Locally Centrally	Locally	
6623	Optg mode changeover	S	Locally Centrally	Centrally	
6624	Manual source lock	S	Locally Segment	Locally	
6625	DHW assignment	S	Local HCs All HCs in segment All HCs in system	All HCs in system	
6631	Ext source in Eco mode	S	Off On DHW On	Off	
6640	Clock mode	C	Autonomously Slave without remote setting Slave with remote setting Master	Autonomously	
6650	Outside temp source	S	0 ... 239	0	
Fault					
6705	SW diagnostic code	E	0 ... 65535	0	
6706	Burn ctrl phase lockout pos	E	0 ... 255	0	
6710	Reset alarm relay	C	No Yes	No	
6740	Flow temp 1 alarm	S	10 ... 240 min	120 min	
6741	Flow temp 2 alarm	S	10 ... 240 min	120 min	
6742	Flow temp 3 alarm	S	10 ... 240 min	120 min	
6743	Boiler temp alarm	S	10 ... 240 min	120 min	
6745	DHW charging alarm	S	1 ... 48 h	8 h	
6800	History 1	S	00:00 ... 23:59 h:m	00:00	
6803	Error code 1	S	0 ... 9999	0	
6805	SW diagnostic code 1	S	0 ... 9999	0	
6806	Burner control phase 1	S	0 ... 255	0	
6810	History 2	S	00:00 ... 23:59 h:m	00:00	
6813	Error code 2	S	0 ... 9999	0	
6815	SW diagnostic code 2	S	0 ... 9999	0	
6816	Burner control phase 2	S	0 ... 255	0	
6820	History 3	S	00:00 ... 23:59 h:m	00:00	
6823	Error code 3	S	0 ... 9999	0	
6825	SW diagnostic code 3	S	0 ... 9999	0	

Line No.	Programme	Access	Control range	Default value	Customer setting
6826	Burner control phase 3	S	0 ... 255	0	
6830	History 4	S	00:00 ... 23:59 h:m	00:00	
6833	Error code 4	S	0 ... 9999	0	
6835	SW diagnostic code 4	S	0 ... 9999	0	
6836	Burner control phase 4	S	0 ... 255	0	
6840	History 5	S	00:00 ... 23:59 h:m	00:00	
6843	Error code 5	S	0 ... 9999	0	
6845	SW diagnostic code 5	S	0 ... 9999	0	
6846	Burner control phase 5	S	0 ... 255	0	
6850	History 6	S	00:00 ... 23:59 h:m	00:00	
6853	Error code 6	S	0 ... 9999	0	
6855	SW diagnostic code 6	S	0 ... 9999	0	
6856	Burner control phase 6	S	0 ... 255	0	
6860	History 7	S	00:00 ... 23:59 h:m	00:00	
6863	Error code 7	S	0 ... 9999	0	
6865	SW diagnostic code 7	S	0 ... 9999	0	
6866	Burner control phase 7	S	0 ... 255	0	
6870	History 8	S	00:00 ... 23:59 h:m	00:00	
6873	Error code 8	S	0 ... 9999	0	
6875	SW diagnostic code 8	S	0 ... 9999	0	
6876	Burner control phase 8	S	0 ... 255	0	
6880	History 9	S	00:00 ... 23:59 h:m	00:00	
6883	Error code 9	S	0 ... 9999	0	
6885	SW diagnostic code 9	S	0 ... 9999	0	
6886	Burner control phase 9	S	0 ... 255	0	
6890	History 10	S	00:00 ... 23:59 h:m	00:00	
6893	Error code 10	S	0 ... 9999	0	
6895	SW diagnostic code 10	S	0 ... 9999	0	
6896	Burner control phase 10	S	0 ... 255	0	
6900	History 11	S	00:00 ... 23:59 h:m	00:00	
6903	Error code 11	S	0 ... 9999	0	
6905	SW diagnostic code 11	S	0 ... 9999	0	
6906	Burner control phase 11	S	0 ... 255	0	
6910	History 12	S	00:00 ... 23:59 h:m	00:00	
6913	Error code 12	S	0 ... 9999	0	
6915	SW diagnostic code 12	S	0 ... 9999	0	
6916	Burner control phase 12	S	0 ... 255	0	
6920	History 13	S	00:00 ... 23:59 h:m	00:00	
6923	Error code 13	S	0 ... 9999	0	
6925	SW diagnostic code 13	S	0 ... 9999	0	
6926	Burner control phase 13	S	0 ... 255	0	
6930	History 14	S	00:00 ... 23:59 h:m	00:00	
6933	Error code 14	S	0 ... 9999	0	
6935	SW diagnostic code 14	S	0 ... 9999	0	
6936	Burner control phase 14	S	0 ... 255	0	
6940	History 15	S	00:00 ... 23:59 h:m	00:00	
6943	Error code 15	S	0 ... 9999	0	
6945	SW diagnostic code 15	S	0 ... 9999	0	
6946	Burner control phase 15	S	0 ... 255	0	

Line No.	Programme	Access	Control range	Default value	Customer setting
6950	History 16	S	00:00 ... 23:59 h:m	00:00	
6953	Error code 16	S	0 ... 9999	0	
6955	SW diagnostic code 16	S	0 ... 9999	0	
6956	Burner control phase 16	S	0 ... 255	0	
6960	History 17	S	00:00 ... 23:59 h:m	00:00	
6963	Error code 17	S	0 ... 9999	0	
6965	SW diagnostic code 17	S	0 ... 9999	0	
6966	Burner control phase 17	S	0 ... 255	0	
6970	History 18	S	00:00 ... 23:59 h:m	00:00	
6973	Error code 18	S	0 ... 9999	0	
6975	SW diagnostic code 8	S	0 ... 9999	0	
6976	Burner control phase 18	S	0 ... 255	0	
6980	History 19	S	00:00 ... 23:59 h:m	00:00	
6983	Error code 19	S	0 ... 9999	0	
6985	SW diagnostic code 19	S	0 ... 9999	0	
6986	Burner control phase 19	S	0 ... 255	0	
6990	History 20	S	00:00 ... 23:59 h:m	00:00	
6993	Error code 20	S	0 ... 9999	0	
6995	SW diagnostic code 20	S	0 ... 9999	0	
6996	Burner control phase 20	S	0 ... 255	0	
Service/special operation					
7040	Burner hours interval	S	100 ... 10000 h	1500 h	
7041	Burn hrs since maintenance	S	0 ... 10000 h	0 h	
7042	Burner start interval	S	100 ... 65500	9000	
7043	Burn starts since maint	S	0 ... 65535	0	
7044	Maintenance interval	S	1 ... 240 months	24 months	
7045	Time since maintenance	S	1 ... 240 months	0 month	
7050	Fan speed ionization current	S	0 ... 10000 rpm	0	
7051	Message ionization current	S	No Yes	No	
7130	Chimney sweep function	E	Off On	Off	
7131	Burner output	E	Partial load Full load Max heating load	Max heating load	
7140	Manual control	E	Off On	Off	
7143	Controller stop function	S	Off On	Off	
7145	Controller stop setpoint	S	0 ... 100 %	0 %	
7146	Deaeration function	C	Off On	On	
7147	Type of venting	C	None Heating circuit continuous Heating circuit cycled DHW continuous DHW cycled	None	
7170	Telephone customer service	C	0 ... 9	0	
Input/output test					
7700	Relay test	C	No test Everything off Relay output QX1 Relay output QX2 Relay output QX3 Relay output QX4 Relay output QX21 module 1 Relay output QX22 module 1 Relay output QX23 module 1 Relay output QX21 module 2 Relay output QX22 module 2 Relay output QX23 module 2 Relay output QX21 module 3 Relay output QX22 module 3 Relay output QX23 module 3	No test	

Line No.	Programme	Access	Control range	Default value	Customer setting
7730	Outside temp B9	C	-50 ... 50 °C	0 °C	
7750	DHW temp B3/B38	C	0 ... 140 °C	0 °C	
7760	Boiler temp B2	C	0 ... 140 °C	0 °C	
7820	Sensor temp BX1	C	-28 ... 350 °C	0 °C	
7821	Sensor temp BX2	C	-28 ... 350 °C	0 °C	
7822	Sensor temp BX3	C	-28 ... 350 °C	0 °C	
7823	Sensor temp BX4	C	-28 ... 350 °C	0 °C	
7830	Sensor temp BX21 module 1	C	-28 ... 350 °C	0 °C	
7831	Sensor temp BX22 module 1	C	-28 ... 350 °C	0 °C	
7832	Sensor temp BX21 module 2	C	-28 ... 350 °C	0 °C	
7833	Sensor temp BX22 module 2	C	-28 ... 350 °C	0 °C	
7834	Sensor temp BX21 module 3	C	-28 ... 350 °C	0 °C	
7835	Sensor temp BX22 module 3	C	-28 ... 350 °C	0 °C	
7840	Voltage signal H1	C	0 ... 10 V	0 V	
7841	Contact state H1	C	Open Closed	Open	
7845	Voltage signal H2 module 1	C	0 ... 10 V	0 V	
7846	Contact state H2 module 1	C	Open Closed	Open	
7848	Voltage signal H2 module 2	C	0 ... 10 V	0 V	
7849	Contact state H2 module 2	C	Open Closed	Open	
7851	Voltage signal H2 module 3	C	0 ... 10 V	0 V	
7852	Contact state H2 module 3	C	Open Closed	Open	
7854	Voltage signal H3	C	0 ... 10 V	0 V	
7855	Contact state H3	C	Open Closed	Open	
7860	Contact state H4	C	Open Closed	Open	
7862	Frequency H4	C	0 ... 2000	0	
7865	Contact state H5	C	Open Closed	Open	
7872	Contact state H6	C	Open Closed	Open	
7874	Contact state H7	C	Open Closed	Open	
7950	Input EX21 module 1	C	0V 230V	0 V	
7951	Input EX21 module 2	C	0V 230V	0 V	
7952	Input EX21 module 3	C	0V 230V	0 V	
State					
8000	State heating circuit 1	C	0 ... 255	0	
8001	State heating circuit 2	C	0 ... 255	0	
8002	State heating circuit 3	C	0 ... 255	0	
8003	State DHW	C	0 ... 255	0	
8005	State boiler	C	0 ... 255	0	
8007	State solar	C	0 ... 255	0	
8008	State solid fuel boiler	C	0 ... 255	0	
8009	State burner	C	0 ... 255	0	
8010	State buffer	C	0 ... 255	0	
8011	State swimming pool	C	0 ... 255	0	
Diagnostics cascade					
8100	Priority source 1	C	0 ... 16	0	
8101	State source 1	C	Missing Faulty Manual control active Heat generation lock active Chimney sweep funct active Temporarily unavailable Outside temp limit active Not released Released	Missing	

Line No.	Programme	Access	Control range	Default value	Customer setting
8102	Priority source 2	C	0 ... 16	0	
8103	State source 2	C	<i>Ditto line 8101</i>	Missing	
8104	Priority source 3	C	0 ... 16	0	
8105	State source 3	C	<i>Ditto line 8101</i>	Missing	
8106	Priority source 4	C	0 ... 16	0	
8107	State source 4	C	<i>Ditto line 8101</i>	Missing	
8108	Priority source 5	C	0 ... 16	0	
8109	State source 5	C	<i>Ditto line 8101</i>	Missing	
8110	Priority source 6	C	0 ... 16	0	
8111	State source 6	C	<i>Ditto line 8101</i>	Missing	
8112	Priority source 7	C	0 ... 16	0	
8113	State source 7	C	<i>Ditto line 8101</i>	Missing	
8114	Priority source 8	C	0 ... 16	0	
8115	State source 8	C	<i>Ditto line 8101</i>	Missing	
8116	Priority source 9	C	0 ... 16	0	
8117	State source 9	C	<i>Ditto line 8101</i>	Missing	
8118	Priority source 10	C	0 ... 16	0	
8119	State source 10	C	<i>Ditto line 8101</i>	Missing	
8120	Priority source 11	C	0 ... 16	0	
8121	State source 11	C	<i>Ditto line 8101</i>	Missing	
8122	Priority source 12	C	0 ... 16	0	
8123	State source 12	C	<i>Ditto line 8101</i>	Missing	
8124	Priority source 13	C	0 ... 16	0	
8125	State source 13	C	<i>Ditto line 8101</i>	Missing	
8126	Priority source 14	C	0 ... 16	0	
8127	State source 14	C	<i>Ditto line 8101</i>	Missing	
8128	Priority source 15	C	0 ... 16	0	
8129	State source 15	C	<i>Ditto line 8101</i>	Missing	
8130	Priority source 16	C	0 ... 16	0	
8131	State source 16	C	<i>Ditto line 8101</i>	Missing	
8138	Cascade flow temp	C	0 ... 140 °C	0 °C	
8139	Cascade flow temp setp	C	0 ... 140 °C	0 °C	
8140	Cascade return temp	C	0 ... 140 °C	0 °C	
8141	Cascade return temp setp	C	0 ... 140 °C	0 °C	
8150	Source seq ch'over current	C	0 ... 990 h	0 h	
Diagnostics heat generation					
8304	Boiler pump Q1	S	Off On	Off	
8308	Boiler pump speed	S	0 ... 100 %	0 %	
8309	Bypass pump speed	S	0 ... 100 %	0 %	
8310	Boiler temp	C	0 ... 140 °C	0 °C	
8311	Boiler setpoint	C	0 ... 140 °C	0 °C	
8312	Boiler switching point	C	0 ... 140 °C	0 °C	
8313	Control sensor	C	0 ... 140 °C	0 °C	
8314	Boiler return temp	C	0 ... 140 °C	0 °C	
8315	Boiler return temp set	C	0 ... 140 °C	0 °C	
8316	Flue gas temp	C	0 ... 350 °C	0 °C	
8318	Flue gas temp max	C	0 ... 350 °C	0 °C	
8321	Primary exchanger temp	C	0 ... 140 °C	0 °C	
8323	Fan speed	C	0 ... 10000 tr/min	0 tr/min	

Line No.	Programme	Access	Control range	Default value	Customer setting
8324	Set point fan	C	0 ... 10000 tr/min	0 tr/min	
8325	Current fan control	C	0 ... 100 %	0 %	
8326	Burner modulation	C	0 ... 100 %	0 %	
8327	Water pressure	C	0 ... 10	0	
8329	Ionization current	S	0 ... 100 µA	0 µA	
8330	Hours run 1st stage	S	00:00:00 ... 2730:15:00 h	00:00:00 h	
8331	Start counter 1st stage	S	0 ... 2147483647	0	
8338	Hours run heating mode	E	00:00:00 ... 8333:07:00 h	00:00:00 h	
8339	Hours run DHW	E	00:00:00 ... 8333:07:00 h	00:00:00 h	
8390	Current phase number	S	TNB TLO TNN STY STV THL1 THL1A TV TBRE TW1 TW2 TVZ TSA1 TSA2 TI MOD THL2 THL2A TN SAV STO	TNB	
8499	Collector pump 1	S	Off On	0	
8501	Solar ctrl elem buffer	S	Off On	0	
8502	Solar ctrl elem swi pool	S	Off On	0	
8505	Speed collector pump 1	S	0 ... 100 %	0 %	
8506	Speed solar pump ext exch	S	0 ... 100 %	0 %	
8507	Speed solar pump buffer	S	0 ... 100 %	0 %	
8508	Speed solar pump swi pool	S	0 ... 100 %	0 %	
8510	Collector temp 1	C	-28 ... 350 °C	0 °C	
8511	Collector temp 1 max	C	-28 ... 350 °C	-28 °C	
8512	Collector temp 1 min	C	-28 ... 350 °C	350 °C	
8513	dt collector 1/DHW	C	-168 ... 350 °C	0 °C	
8514	dt collector 1/buffer	C	-168 ... 350 °C	0 °C	
8515	dt collector 1/swimming pool	C	-168 ... 350 °C	0 °C	
8519	Solar flow temp	C	-28 ... 350 °C	0 °C	
8520	Solar return temp	C	-28 ... 350 °C	0 °C	
8526	24-hour yield solar energy	E	0 ... 999,9 kW/h	0 kW/h	
8527	Total yield solar energy	E	0 ... 9999999,9 kW/h	0 kW/h	
8530	Hours run solar yield	E	00:00:00 ... 8333:07:00 h	00:00:00 h	
8531	Hours run collect overtemp	E	00:00:00 ... 8333:07:00 h	00:00:00 h	
8532	Hours run collector pump	E	00:00:00 ... 8333:07:00 h	00:00:00 h	
8560	Solid fuel boiler temp	C	0 ... 140 °C	0 °C	
8570	Hours run solid fuel boiler	E	00:00:00 ... 8333:07:00 h	00:00:00 h	
Diagnostics consumers					
8700	Outside temp	C	-50 ... 50 °C	0 °C	
8701	Outside temp min	E	-50 ... 50 °C	50 °C	
8702	Outside temp max	E	-50 ... 50 °C	-50 °C	
8703	Outside temp attenuated	C	-50 ... 50 °C	0 °C	
8704	Outside temp composite	C	-50 ... 50 °C	0 °C	
8730	Heating circuit pump 1	C	Off On	Off	
8731	Heat circ mix valv 1 open	C	Off On	Off	
8732	Heat circ mix valv 1 close	C	Off On	Off	
8735	Speed heating circuit pump 1	S	0 ... 100 %	0 %	
8740	Room temp 1	C	0 ... 50 °C	20 °C	
8741	Room setpoint 1	C	4 ... 35 °C	20 °C	
8743	Flow temp 1	C	0 ... 140 °C	60 °C	
8744	Flow temp setpoint 1	C	0 ... 140 °C	60 °C	

Line No.	Programme	Access	Control range	Default value	Customer setting
8749	Room thermostat 1	C	No demand Demand	No demand	
8760	Heating circuit pump 2	C	Off On	Off	
8761	Heat circ mix valv 2 open	C	Off On	Off	
8762	Heat circ mix valv 2 close	C	Off On	Off	
8765	Speed heating circuit pump 2	S	0 ... 100 %	0 %	
8770	Room temp 2	C	0 ... 50 °C	20 °C	
8771	Room setpoint 2	C	4 ... 35 °C	20 °C	
8773	Flow temp 2	C	0 ... 140 °C	60 °C	
8774	Flow temp setpoint 2	C	0 ... 140 °C	60 °C	
8779	Room thermostat 2	C	No demand Demand	No demand	
8790	Heating circuit pump 3	C	Off On	Off	
8791	HC mixing valve 3 open	C	Off On	Off	
8792	HC mixing valve 3 closed	C	Off On	Off	
8795	Speed heating circuit pump 3	S	0 ... 100 %	0 %	
8800	Room temp 3	C	0 ... 50 °C	20 °C	
8801	Room setpoint 3	C	4 ... 35 °C	20 °C	
8803	Flow temp 3	C	0 ... 140 °C	60 °C	
8804	Flow temp setpoint 3	C	0 ... 140 °C	60 °C	
8809	Room thermostat 3	C	No demand Demand	No demand	
8820	DHW pump	C	Off On	Off	
8825	Speed DHW pump	S	0 ... 100 %	0 %	
8826	Speed DHW interm circ pump	S	0 ... 100 %	0 %	
8827	Speed inst DHW heater pump	S	0 ... 100 %	0 %	
8830	DHW temp 1	C	0 ... 140 °C	0 °C	
8831	DHW temp setpoint	C	8 ... 80 °C	55 °C	
8832	DHW temp 2	C	0 ... 140 °C	0 °C	
8835	DHW circulation temp	C	0 ... 140 °C	0 °C	
8836	DHW charging temp	C	0 ... 140 °C	0 °C	
8852	DHW consumption temp	C	0 ... 140 °C	0 °C	
8853	Instant WH setpoint	C	0 ... 140 °C	0 °C	
8860	DHW flow	C	0 ... 30 l/min	0 l/min	
8875	Flow temp setp VK1	C	5 ... 130 °C	5 °C	
8885	Flow temp setp VK2	C	5 ... 130 °C	5 °C	
8895	Flow temp setp swimming pool	C	5 ... 130 °C	5 °C	
8900	Swimming pool temp	C	0 ... 140 °C	0 °C	
8901	Swimming pool setpoint	C	8 ... 80 °C	24 °C	
8930	Primary controller temp	C	0 ... 140 °C	0 °C	
8931	Primary controller set	C	0 ... 140 °C	0 °C	
8950	Common flow temp	C	0 ... 140 °C	0 °C	
8951	Common flow temp setp	C	0 ... 140 °C	0 °C	
8952	Common return temp	C	0 ... 140 °C	0 °C	
8962	Common output setpoint	C	0 ... 100 %	0 %	
8980	Buffer temp 1	C	0 ... 140 °C	0 °C	
8981	Buffer setpoint	C	0 ... 140 °C	0 °C	
8982	Buffer temp 2	C	0 ... 140 °C	0 °C	
8983	Buffer temp 3	C	0 ... 140 °C	0 °C	
9005	Water pressure H1	C	0 ... 10 bar	0 bar	
9006	Water pressure H2	C	0 ... 10 bar	0 bar	
9009	Water pressure H3	C	0 ... 10 bar	0 bar	

Line No.	Programme	Access	Control range	Default value	Customer setting
9031	Relay output QX1	C	Off On	Off	
9032	Relay output QX2	C	Off On	Off	
9033	Relay output QX3	C	Off On	Off	
9034	Relay output QX4	C	Off On	Off	
9050	Relay output QX21 module 1	C	Off On	Off	
9051	Relay output QX22 module 1	C	Off On	Off	
9052	Relay output QX23 module 1	C	Off On	Off	
9053	Relay output QX21 module 2	C	Off On	Off	
9054	Relay output QX22 module 2	C	Off On	Off	
9055	Relay output QX23 module 2	C	Off On	Off	
9056	Relay output QX21 module 3	C	Off On	Off	
9057	Relay output QX22 module 3	C	Off On	Off	
9058	Relay output QX23 module 3	C	Off On	Off	
Burner control					
9504	Required speed prepurging	S	0 ... 10000 tr/min	Depending on boiler	
9512	Required speed ignition	S	0 ... 10000 tr/min	Depending on boiler	
9524	Required speed LF	S	0 ... 10000 tr/min	Depending on boiler	
9525	Required speed LF min	S	0 ... 10000 tr/min	Depending on boiler	
9529	Required speed HF	S	0 ... 10000 tr/min	Depending on boiler	
9530	Required speed HF max	S	0 ... 10000 tr/min	Depending on boiler	
9650	Chimney drying	S	Off Temporarily Permanently	Off	
9651	Req speed chimney drying	S	0 ... 10000 tr/min	500 tr/min	
9652	Duration chimney drying	S	10 ... 1440 min	10 min	

12. ANNEX A

Data on products ≤ 400 kW

Product reference												
Trade mark			YGNIS									
Models			120	140	180	225	275	320	390			
Nominal power			Prated	kW		117	136	175	219	268	312	381
Useful heat production												
At nominal power and in 80°C / 60°C regime			P ₄	kW		117,2	136,8	175,7	219,6	269,2	313,3	381,4
			η_4 (PCS)	%		87,9	87,9	87,8	87,8	88,1	88,1	88,0
At 30% nominal power and in 30°C return temperature regime			P ₁	kW		39,2	45,7	58,9	73,6	89,8	104,5	127,4
			η_1 (PCS)	%		97,9	97,9	98,2	98,2	98,0	98,0	98,0
Auxiliary electricity consumption												
Under full load			elmax	kW		0,204	0,311	0,179	0,32	0,238	0,352	0,480
Under partial load			elmin	kW		0,101	0,119	0,101	0,124	0,178	0,194	0,219
In standby mode			P _{SB}	kW		0,005	0,005	0,005	0,005	0,005	0,005	0,005
Other properties												
Heat loss			Pstby	kW		0,182	0,182	0,213	0,213	0,259	0,259	0,311
Nitrogen oxide emissions			Nox (PCS)	mg/kWh		27	27	27	27	36	36	32

**SATC ATLANTIC GUILLOT**

1 route de Fleurville
01190 PONT DE VAUX
Tél. : 03 51 42 70 03

N°Indigo **0 825 396 634**

Fax : 03 85 51 59 30 0,15 € TTC / MN
www.atlantic-guillot.fr

**THERMOR SERVICES**

17 rue Croix Fauchet - BP 46
45141 SAINT-JEAN-DE-LA-RUELLE
Tel.: N°Azur **0 810 081 045**

www.thermor.fr

**ATLANTIC BELGIUM SA**

Avenue du Château Jaco, 1
1410 WATERLOO
Tel. : 02/357 28 28
Fax : 02/351 49 72

www.ygnis.be

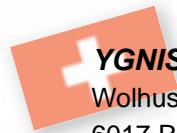
**YGNIS AG**

Wolhuserstrasse 31/33
6017 RUSWIL CH
Tel.: +41 (0) 41 496 91 20
Fax : +41 (0) 41 496 91 21
Hotline : 0848 865 865

www.ygnis.ch

**YGNIS ITALIA SPA**

Via Lombardia, 56
21040 CASTRONNO (VA)
Tel.: 0332 895240 r.a.
Fax : 0332 893063

www.ygnis.it

**HAMWORTHY HEATING LIMITED**

Customer Service Center
Fleets Corner, POOLE,
Dorset BH17 0HH
Tel.: 0845 450 2865
Fax.: 01202 662522
service@hamworthy-heating.com

www.hamworthy-heating.com

**ATLANTIC IBERICA SAU**

Servicio de Asistencia Técnica Ygnis
Calle Molinot 59-61
Pol Ind Camí Ral
08860 CASTELLDEFELS (BARCELONA)
Tel. : 902 45 45 22
Fax : 902 45 45 20

callcenter@groupe-atlantic.com
repuestos@groupe-atlantic.com
www.ygnis.es

Others countries, contact your local retailer



SITE DE PONT-DE-VAUX

1 route de Fleurville - BP 55
FR - 01190 PONT-DE-VAUX